



## Thank you for reaching out.

**Vendela Hellena<sup>1</sup>, Chok Zu Bing<sup>2</sup>, Manzoor Hussain<sup>3</sup>, Derek Lee Zi Jie<sup>4</sup>, Farahlina Jasmin Binti Mohd Yunus<sup>5</sup>, Liew Zhan Leong<sup>6</sup>, Sumathi Balakhrisnan<sup>7</sup>, <sup>8</sup>Imdad Ali Shah**

<sup>1,2,4,5,6,7,8</sup> School of Computer Science, Taylor's University, Subang Jaya, Selangor Malaysia

<sup>3</sup> Computing Department Faculty of Computing & Information Technology, Indus University, Karachi Pakistan

---

**Article History:** Received: 02.10.2022

Revised: 23.12.2022

Accepted: 17.01.2023

---

### Abstract.

Nowadays, many people tend to have pets at home, and it is no doubt that pets make excellent companions for humans. However, many pet owners have found it is difficult to take care of their beloved pets whenever they must leave the house. Having no choice but to leave their pets unattended has raised many unwanted problems towards both pet owners and their pets. Based on the survey of 41 pet owners, 82.9% of the respondents agree that it is troublesome to feed their pets while they are away, and the most concerns are about the feeding, pets' emotional feeling, and pets' living environment. With this information, a smart pet feeder utilising the concept of the Internet of Things is designed with functionalities that address those top problems. The smart pet feeder is designed to ease pet owners to automatically feed their pets, interact with their pets in a real-time manner, and monitor their pets' living environment with the help of the internet and various sensors without them needing to be around the feeder. Arduino Uno board is utilised as the brain of the system, with numerous sensors and modules to serve different functionalities, including weight sensor, temperature sensor, PIR sensor camera module, speaker module, servo motor, LED, and piezo buzzer. A mobile app is designed as well, with the role of being the media for pet owners to control the smart pet feeder remotely using the internet connection. Aside from the mobile app, the smart pet feeder is still controllable manually via the buttons on the smart pet feeder itself.

---

### 1. INTRODUCTION

Our proposed idea is an automated smart pet feeder which utilises Internet of Things (IoT) technology to bring numerous advantages to pet owners. The general objective of the smart pet feeder is to offer great conveniences to its users as opposed to the users of a traditional gravity bin pet feeder. The traditional gravity bin pet feeder does not have any integrated sensors. For instance, it does not have a weight sensor to measure the amount of food and water left. Hence, the users must check on the pet feeder regularly to ensure that there is a sufficient amount of food and water in the pet feeder. To compare, the proposed smart pet feeder is integrated with a lot of sensors that provide

different functions respectively [1-3]. These sensors will help in determining the amount of food and water left in the smart pet feeder, determining the temperature, and detecting any movements in a certain area around the smart pet feeder. All this information would be displayed in the dedicated mobile app named 'Toby' which can be downloaded from the mobile application store such as Play Store and App Store. Hence, when the pet owners are far away from the pet feeder, they would still be aware of all this necessary information as they will be notified via the mobile app.

---

<sup>1,2,4,5,6,7,8</sup> School of Computer Science, Taylor's University, Subang Jaya, Selangor Malaysia

<sup>3</sup> Computing Department Faculty of Computing & Information Technology, Indus University, Karachi Pakistan

## 2. LITERATURE REVIEW

An automatic pet feeder was developed using Arduino as the brain of the system. This automatic pet feeder is designed to be remotely controllable using a mobile app. Two different communication architectures were presented in this project [4-7]. In the first architecture, the communication between the automatic pet feeder and the mobile app uses Global System for Mobile Communications (GSM) / General Packet Radio Service (GPRS) communication services, whereas in the second architecture, the Twitter social network is used instead as the communication service. Arduino board was chosen in this project due to several reasons, for instance, Arduino is multi-platform, inexpensive, open-source, with a simple

programming language [8-10]. For implementing GSM / GPRS, Sim900 module was used, whereas to implement Twitter social network, ESP8266 Wi-Fi module which is integrated to TCP / IP protocol stack was chosen due to the reason that it is web-friendly, versatile and inexpensive [11,12]. Combining these two communication methods increases the flexibility of this system. When the users do not have any access to the internet, communication could be performed using the GSM / GPRS via SMS. On the other hand, the communication could still carry on when the users only have access to the internet using the Twitter social network. Fig 1 shows the System Architecture showing the Arduino board, Sim900, ESP8266 Wi-Fi Module and DC motors.

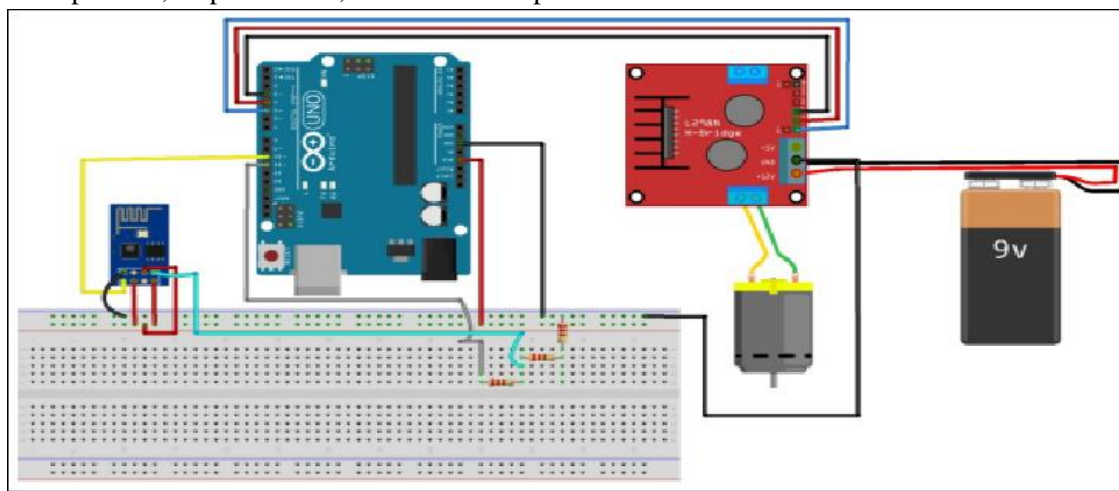

**FIGURE 1.** shows the System Architecture showing the Arduino board, Sim900, ESP8266 Wi-Fi Module and DC motors [2].

A smart pet feeder connected to a mobile app was developed in a final year project report. The Arduino board was used as the brain of the system, similar to the project by Quiñonez et al. (2021) above. A Wi-Fi module was used to connect the smart pet feeder to the Wi-Fi for it to be controlled remotely using the mobile app [13-15]. An external IP camera was added to the system as well. The only actuator used in this project is the micro servo motor, which was used to handle the position of the container lid, whether to open or close. BLYNK app was used to develop a mobile app to control the smart pet feeder. BLYNK platform is customizable with a lot of available libraries without the users needing to program at all [16]. However, the IP camera could not be integrated into BLYNK, thus needing another app, which is MYDLINK. Both of these apps store the data into the cloud. Videos generated from the IP camera would be AES-

128 encrypted to ensure its security, where data transportation from BYLINK to the server would be secured using SSL gateway. Another project similar to Hakim et al. (2020) and Quiñonez et al. (2021) were published, where the Arduino board is implemented as the brain of the entire system as well [17-19]. This automatic pet feeder is designed to be remotely controllable using a mobile app. However, only the ESP8266 Wi-Fi module was implemented rather than using Global System for Mobile Communications (GSM) / General Packet Radio Service (GPRS) communication services. BLYNK app was utilised as well to develop a mobile app to control the smart pet feeder; however, unlike Hakim et al. (2020), this project does not implement an IP camera in the system. Fig 2 shows the components of Arduino board, ESP8266 Wi-Fi Module and BLYNK mobile app

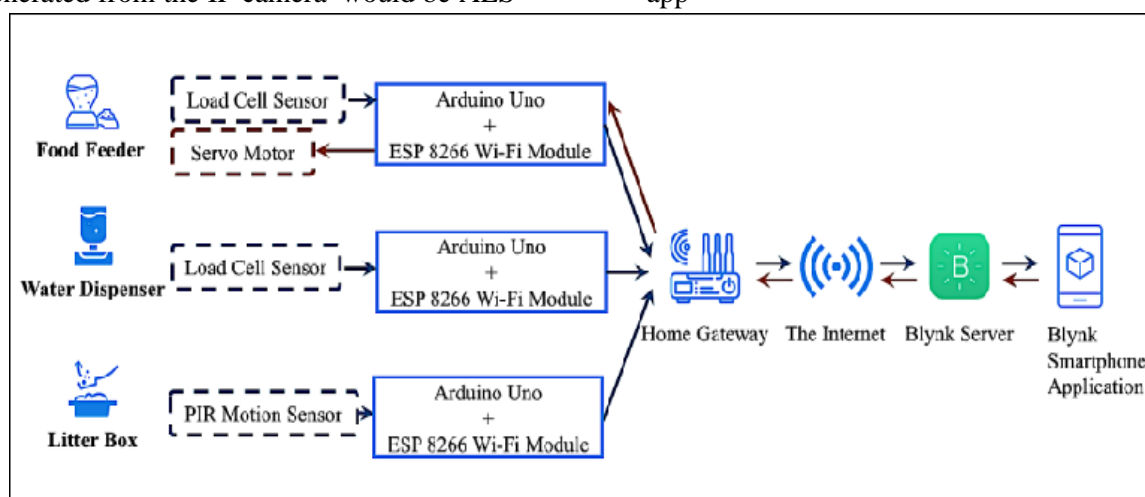

**FIGURE 2 shows the components of Arduino board, ESP8266 Wi-Fi Module and BLYNK mobile app [9]**

In the 21st century, people have been living in the digital age where the grand development of man-made machines are capable of overcoming any issues [21-23]. Few of the technologies have been implemented into the smart pet feeder such as using Wi-Fi to control the pet feeder for setting the feeding schedule and the food portion. To cope up with the advancement of the technology, a single board computer named Raspberry Pi and Arduino board was introduced to create the smart pet feeder (see Fig. 3). These affordable tiny motherboards are found to be great for

hobbyists, beginners and professionals to create Internet of Things (IoT) at lower cost, just about \$23-\$35 [25-26]. In addition to that, it has the necessary I/O ports and panels for sensors, lights and switches to be connected easily without any hassle. Thus, making it easier for hobbyists, beginners and professionals to create the prototype of their ideas. Fig 4 shows the Raspberry.



(a)



(b)

**FIGURE 3.** (a) Raspberry Pi [14]. (b) Arduino Uno [15]

To sort up the complications of choosing which board to be used in developing the smart pet feeder, a simple rule of thumb can be remembered. A Raspberry Pi board is like a general-purpose computer where it has the versatility to multitask different programs, making it harder for beginners to approach at first [27-29]. Thus, the board is able to do intense workload and calculation. An Arduino board however, is a simple computer designed to run one program at a time, making it easier for beginners to approach. Thus, it is best suited for doing simple repetitive tasks. To summarise in a nutshell, it can be described in real-life scenarios. "I want to feed my dog at 1:00 P.M and have the machine to notify me once the food has been dispensed and notify me again once the food has been finished by my pets, and if the bowl is empty, turn on the LED lights and if the bowl is not empty, do nothing." "I want to feed my dog at 1:00 P.M and have the machine to notify me once the food has been dispensed."

Derived from above examples, the statement of which board to be used in developing the smart pet feeder is justified [31-33]. Once a board is chosen, it is necessary to know what tools should be connected to the board in order to create a multi-purpose smart pet feeder. For instance, it is necessary to include a servo motor (AC / DC) to control the lid of the container in order for the pets' food to be dispensed onto the bowl. AC motors are suggested to be more powerful than DC motors since AC motors have higher input of energy which will then generate higher torque [34]. Yet, DC motors are more energy-efficient due to its lower input of energy which will then generate lower torque. It is suggested to use DC motors since a pet's food is usually a biscuit which is lightweight. Hence, by using DC motors, the efficient usage of energy could be ensured.

Talking about energy, having the correct energy input to power-up the board is an essential part of the whole entire automation

series. This is because Raspberry Pi and Arduino only allow the operating voltage of 5V [35]. Powering through the USB port could solve the issues, however, it could run a risk of a pet accidentally tripping over the exposed wire or damaging the wire due to their nature of chewing and eating. Nevertheless, running a 4 AA battery with 5V resistor divider could only last for 5-7 hours [36-38]. Besides, having several key components such as a camera, sensor or display could also potentially ruin the battery life. Hence, it is crucial to choose the correct energy input for the smart pet feeder as it may ruin the whole system.

The most common question that people always ask is, why is ESP8266 being used so commonly by many hobbyists or professionals? Firstly, the boards are cheap, it just costs approximately \$4 to \$6 (depending on region, the price may differ). These modules are commonly found on the market which makes it easier for many people to buy. Due to its high population of people owning it, it has a larger active community to share and discuss the related topics together which makes it less complicated for programmers and hobbyists to use it on a Arduino board or Raspberry Pi [39]. Additionally, it has more compatibility in terms of using it in different programming languages, making once more easier for everyone to build the prototype of their ideas. Speaker, being the one of the important items in the smart pet feeder plays an important role in terms of attracting the pets' attention as well as constructing a psychological association between the pets and smart pet feeder. Classical Conditioning is known as a type of psychological association where learning happens unconsciously [40-42]. It associates an involuntary response and a stimulus. For instance, if the pet sees the food and the bell rings at the same time, the pet will form an association between the bell and food. So, when the bell rings, the pet will automatically be aware that food is about to be served (refers to Fig. 4).

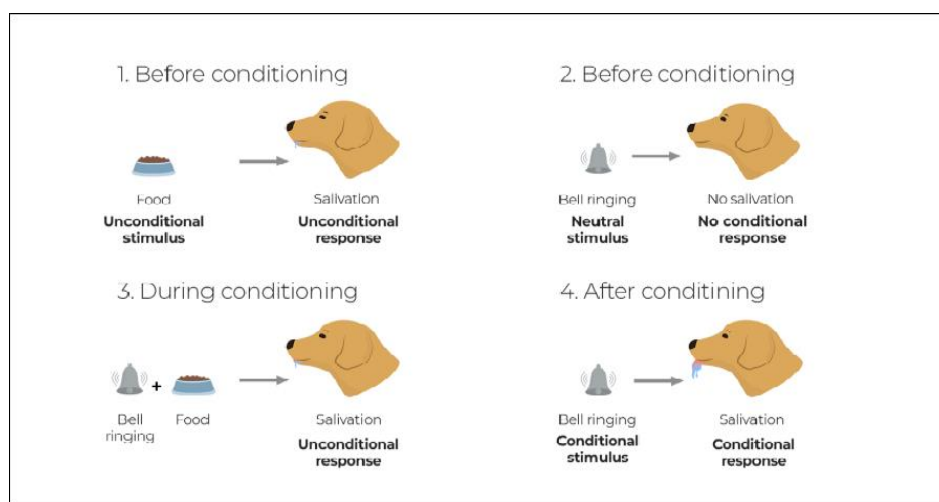

**FIGURE 4. Example of Classical Conditioning**  
[26]

Hence, by having a speaker for a smart pet feeder, the pet will automatically be aware and attracted to the pet feeder once the speaker buzzes or rings due to the psychological phenomenon known as Classical Conditioning. Therefore, if the responsible owner is away from the house and a pet is resting somewhere else, a buzzer or rings can alert the pet to eat their respective food [43-44]. With that being said, the proposed objective of having a smart pet feeder is to ensure that the pet is being well-fed throughout the time while the owner no longer needs to be worried about their pet during their absence. Not only that, the creation of a smart pet feeder is also used to address the issue of forgetful owners who often forget to feed their pet on time. Additionally, it could be also used to avoid spending extra money at a pet hotel.

### 3. METHODOLOGY

A survey was conducted using Google Form to understand more about the problem. From the results, the functionalities of the smart pet feeder were designed. Literature reviews were performed by reading through different articles

#### Proposed System Architecture

and reports to study more about similar projects which use Arduino Uno board to understand which components are necessary to implement the smart pet feeder [45-47]. Aside from the physical components, other aspects which are the necessary protocols, paradigm, and software to build the system architecture and enable the smart pet feeder to connect to the internet were studied as well in a similar manner. To execute the idea, Tinkercad was used to build the prototype of the smart pet feeder, where Marvel app is used to build the interactive prototype of the mobile app.

### 4. RESULTS AND FINDINGS

The proposed architecture for this project is divided into six layers, as seen in Fig. 5. This proposed architecture is composed of the following layers: perception, data link, network, transport, application, and data processing. Each layer will be discussed in detail in the subsections below. Fig 5 presents the proposed architecture for the smart pet feeder.

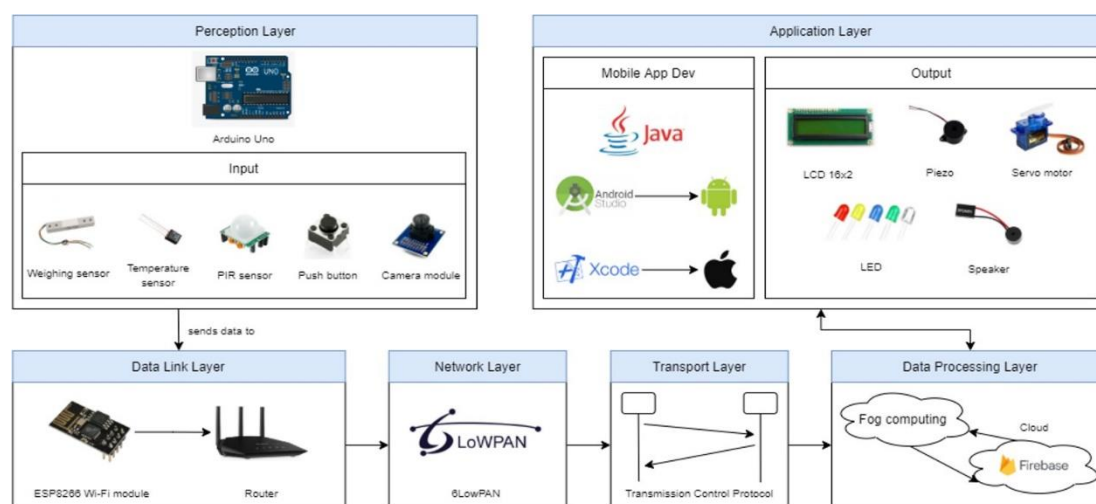

**FIGURE 5. Proposed Architecture for the Smart Pet Feeder**

#### 4.1 Perception Layer

The perception layer is the physical layer, in which sensors are used to detect and collect data on the physical features of objects in our environment [48-50]. This layer will operate all sensors, including temperature and weight sensors, using an Arduino board. The Arduino Board will be programmed in C++. The Arduino board was chosen because it is open-source, affordable, multi-platform, and easy to build due to its simple programming language. Several sensors and modules are used as the input to the system, which are the weight sensor, temperature sensor, PIR sensor, push button, and camera module. Weight sensors or replaceable with force sensors are mounted in the containers and trays. It takes the analog signals from the weight of the food and water, and shows it to the LCD and sends the data to the mobile app using the Wi-Fi module. The same flow applies to the temperature sensor as well. PIR sensor is used to detect movement, where the inputs would be digital signals. It allows pet owners to be notified via the mobile app when there are any movements near the smart pet feeder, be it the pets or any other movements. When activity is detected, the mobile app notifies the owners, who can then use the camera module to inspect the area

around the smart pet feeder. Push buttons are used to control the smart pet feeder manually, which are to open the food or water lid, as well as setting the clock and feeding schedules via the smart pet feeder itself.

#### 4.2 Data Link Layer

The proposed architecture for the data link layer makes use of the Wi-Fi (Wireless Fidelity). Wi-Fi is a wireless local area network where no wiring is involved. Nevertheless, Wi-Fi connects devices within a range of 60 to 100 feet to the internet and transmits and receives data via high-frequency radio signals [51-53]. The most common Wi-Fi module that could be used in Arduino projects is ESP8266, which has an integrated TCP / IP protocol that enables the smart pet feeder to access the Wi-Fi network in the house. This module uses IEEE 802.11 bgn standard, enabling the smart pet feeder to connect to 2.4 GHz Wi-Fi routers. Data from the input such as the weight and temperature information is sent to the network using the Wi-Fi module. As a result, end-users will benefit from the ability to remotely monitor the amount of food or water in their smart pet feeder while they are away from home. Fig 6 6LoWPAN layers that provide a security mechanism.

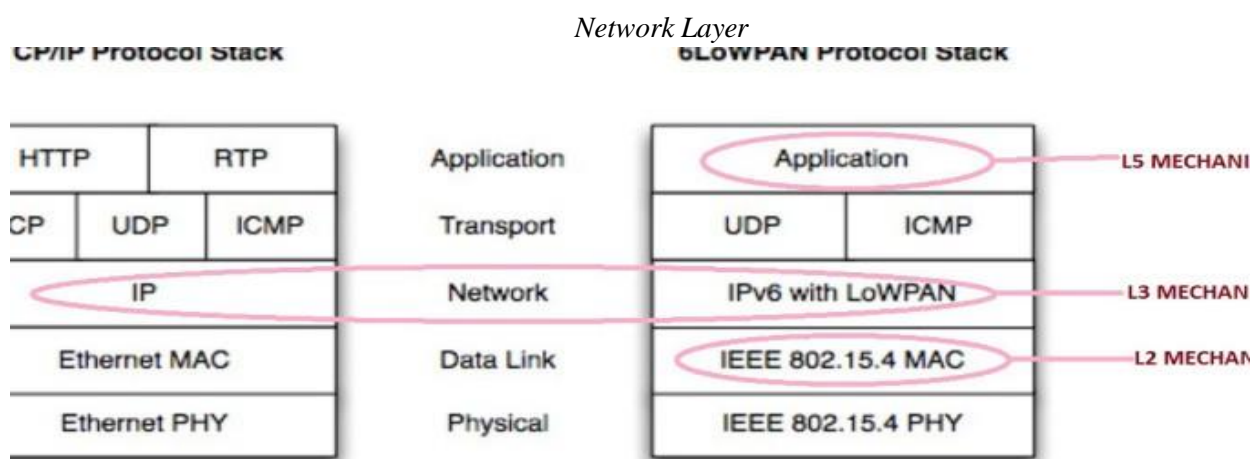

**FIGURE 6 6LoWPAN layers that provide a security mechanism [29]**

The network layer is in charge of data flow between users connected via various networks. It contains logical connections, fault reporting, maintenance, and data routing [54]. This layer

encompasses all network devices, including switches, firewalls, bridges, routers, and communications and routing protocols such as IPv4, IPv6, 6LoWPAN, AppleTalk, ICMP,



and IPX [31].

6LoWPAN will be used in this project since IPv6 addressing allows billions of things in the IoT to be addressed uniquely. Because of this, even the tiniest and lowest-power devices capable of joining the Internet of Things can use Internet Protocol. Moreover, 6LoWPAN offers fragmentation concepts, unicast, multicast, and broadcast communications [55-56]. The 15.4 standard defines a frame as 127 bytes, whereas an IPv6 transmission unit is 1280 bytes. 6LoWPAN enables fragmenting 1280 data into 127 byte frames. 6LoWPAN also supports IP routing and supports mesh networking at the link layer and provides security.

Nevertheless, 6LoWPAN offers security, a growing concern for IoT devices. Wireless radio communications are easily intercepted and have little processing power. As a result, systems' principal security objectives are frequently three-fold: integrity, confidentiality, and availability [57]. 6LoWPAN achieves all of this security via three distinct levels such as application, media access, and network layers, as shown in Fig. 6.

Finally, 6LoWPAN's protocol is appropriate for this project because it supports 64-bit or 16-bit addressing for low-power networks such as Bluetooth low energy or Bluetooth smart, header compression for both IPv4 and UDP headers, network auto-configuration and neighbour discovery, multicast, unicast, and broadcast support, and the fragmentation concept [58]. As a result, 6LoWPAN covers the majority of IPv6 functionality while still supporting low-power devices. 6LoWPAN is an Internet of Things (IoT) protocol that tackles restrictions inherent in IoT systems, making it well-suited for IoT.

#### 4.3 Transport Layer

The transport layer's role is to take data from the application layer, decompose it into smaller units, send these smaller units to the network layer, and ensure that all pieces arrive in the correct sequence at the other end [59]. After then, the receiving side will reassemble the received segments into messages that will be

forwarded straight to

the application layer. As a result, the suggested architecture will communicate using TCP (Transmission Control Protocol). It is a trustworthy connection-oriented protocol that reliably transmits data to the destination machine from the source. As a result, it will collaborate effectively with the smart pet feeder and the end-user to guarantee that all data is obtained. Additionally, it regulates flow to prevent a fast transmitter from overwhelming a slower recipient.

#### 4.4 Application Layer

The mobile app named 'Toby' would be available on Android and iOS. The mobile app enables pet owners to operate the pet feeding while not being present remotely. The smart pet feeder's Wi-Fi module enables it to connect to the internet, allowing it to be managed remotely. The mobile app provides access to all of the smart pet feeder's functions. Pet owners must first create an account to access the mobile app, which may be done within the mobile app. After logging into their account, pet owners will be prompted to connect to their smart pet feeder. To connect the smart pet feeder to an account, pet owners should scan the QR code on the smart pet feeder or manually key in the serial number of the smart pet feeder [60-62]. Following that, pet owners could add more smart pet feeders into their account or enter the smart pet feeder which would display the most critical data and all available functionality. The representation would contain the date and time, the quantity of food and drink available inside the containers and trays, and current temperature. Historical data, such as the amount of food consumed by the pet over the last few days, can also be displayed using a variety of visualisations selected by the pet owner, which are line graphs or bar graphs. The mobile app and the smart pet feeder both have a function for adding food and water. Pet owners can schedule how frequently their pets will be fed throughout the day, as well as the amount of food and water they will receive. Pet owners can use the mobile app to open the built-in camera and see if their pets are nearby the smart

pet feeder. Additionally, the built-in speaker is accessible, allowing pet owners to communicate with their animals.

Pet owners could set a threshold for the amount of food and water available to their pets, and when the threshold is met, the mobile app notifies them that their pet's food and water supplies are running low. Pet owners would also be notified while the containers are empty. According to the pet owner's preferences, these functions can be turned on and off. Apart from the mobile app, the smart pet feeder can be controlled via the buttons on the smart pet feeder itself. Servo motors act as the lid of the container, which would open when the button is pressed or when the scheduled time has arrived. The LED and piezo buzzer serve the purpose of physically notifying pet owners when the amount of food or water is below the threshold set [63-65]. The LCD would display only the most crucial data: the amount of food, water, and temperature. The feeding scheduler function is also accessible via the pet feeder's built-in buttons. This two-way access allows pet owners to control the smart pet feeder to their liking.

The mobile app is built to be compatible with Android and iOS. The programming language used would be Java, where Android version would be built using Android Studio, and iOS version using XCode. Java is known for its mature language since it has a relatively large safe library that is available throughout the internet and its community, and can be considered reasonably performant and standardised [66]. In addition, its biggest advantage compared to C++ or other programming languages is that it is able to cross-platform and run just fine in any other operating system. For the pet owners to be able to sign up using their Google Email or Facebook, Firebase Authenticator is used. Further explanation could be found in the Data Processing Layer subsection below.

Fig 7 presents Layered architecture of fog computing.

**Data Processing Layer**

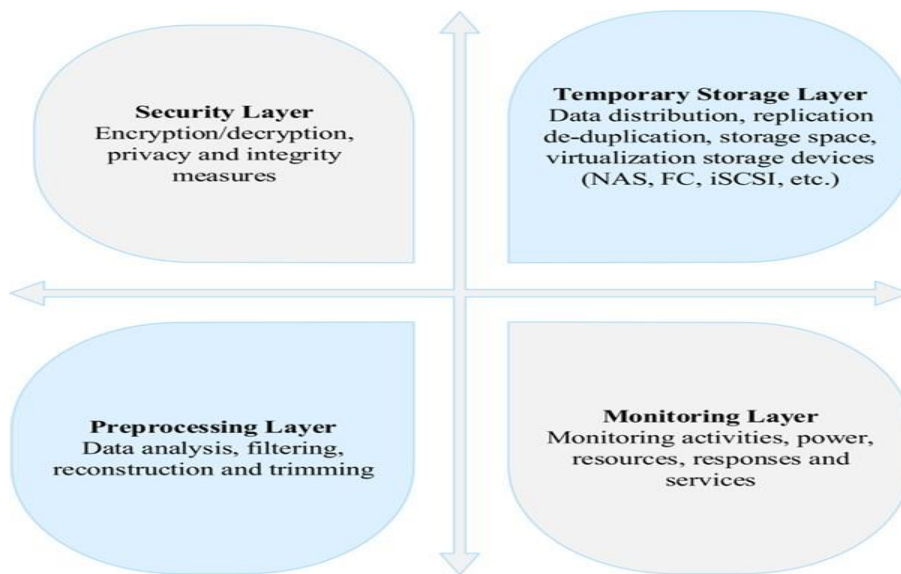

**FIGURE 7** presents Layered architecture of fog computing [34].

The suggested architecture includes a layer of fog and cloud computing that enables data flow between intelligent devices and cloud computing services. The four layers of fog architecture are depicted in Fig. 8: monitoring, pre-processing, storage, and security [67]. By including these layers into the proposed architecture, all data is encrypted and safeguarded, preventing it from being leaked or lost. Cloudlets are little yet mighty data centres located at the network's perimeter. In contrast to cloud computing, fog computing is a distributed system without a central server. Local and remote devices are connected via computing in the form of 'fog'. Depending on the data, it either sends the data to the cloud or processes it locally. Additionally, by implementing fog computing, the underlying network may provide lower latency performance services to end-users. Fog computing nodes provide these benefits to end-users and are preferred over farthest cloud computing for a variety of reasons:

- Low latency: when fog computing is used, latency is minimised since data is sent to the nearest fog nodes, minimising communication time.
- Real-time interactions: as mentioned previously, fog computing enables real-time interactions since the distance between the device and the fog nodes is shorter, allowing data to be processed in real-time.
- Scalability: fog computing enhances the system's scalability by allowing the number of fog nodes to be easily raised as the volume of data grows.
- Power restrictions: the quantity of power consumed can be minimised by shortening the communication distance.

### **Tinkercad Project**

Firebase is used as the cloud database to store the data that requires more complex processing. It's a NoSQL database hosted in the cloud that allows the 'Toby' mobile app to store and sync data in real-time between the users [68]. The database itself will register the user accounts automatically into the server and reverify its authenticity without having an admin to verify it manually. Additionally, if a user forgets their password, the database itself will automatically send an email to their corresponding registered email address. Thus, this ensures real time events to operate in sync without any delays in between the user interaction, giving the user a responsive experience. Firebase API provides the necessary tools for tracking analytics, reporting and fixing app crashes for the developers to be aware as well. Firebase Authentication offers backend services as well as a straightforward SDK for authenticating users to the mobile app via emails and passwords. Firebase Authentication will automatically handle users who sign in using their email and password and save user data to the cloud in a secure manner after the user logs in. Users also will be able to reset their password through emails as well as other features to help them if they had forgotten their password. Moreover, if the users desire a speedier login process, this Firebase SDK will allow them to access the 'Toby' mobile app via other integration such as Facebook and Google login. 'Toby' mobile app will also employ the OTP (One-time password) authentication feature included in this Firebase SDK which will authenticate users by sending a numerical pin number to their corresponding email address to verify their identity.

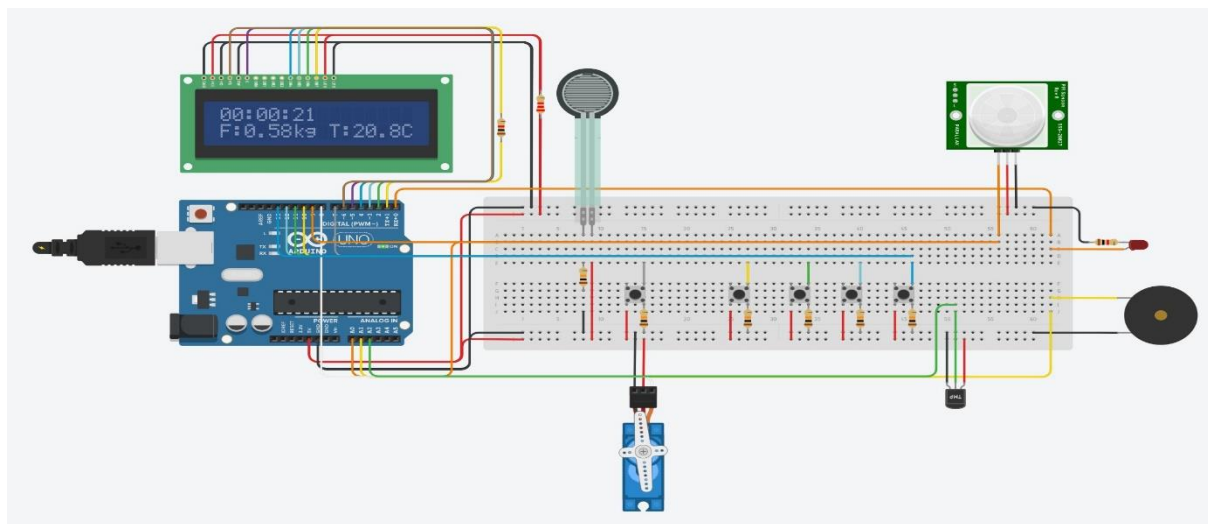
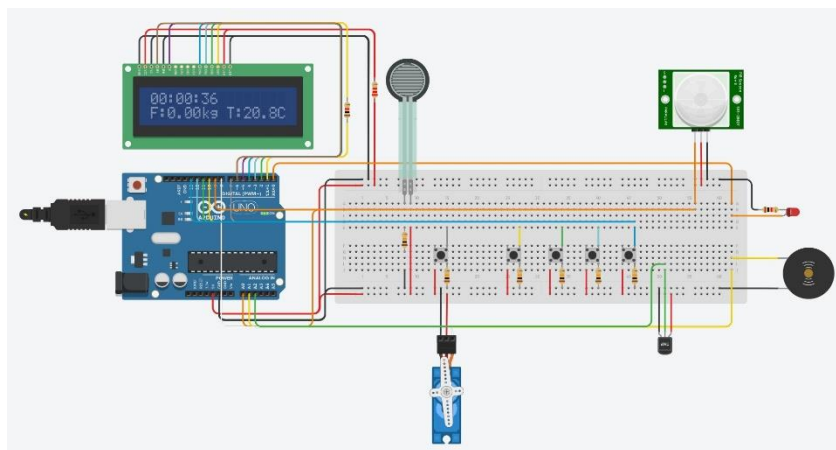

**FIGURE 8.** Smart Pet Feeder System in Tinkercad

Fig. 8 shows the system of the smart pet feeder which is built using Tinkercad. The smart pet feeder would automatically release a certain amount of food and water when the time set by the pet owner comes. This smart pet feeder uses Arduino Uno as its brain. To reduce the risk of the Arduino to be spoiled, breadboards are used. Resistors are utilised as well to limit the power to certain components, which are LED, buttons, and LCD, as they require only a small amount of power and prevent them from blowing up. The time could be set by the pet owners using the mobile app, or using the buttons in the smart pet feeder itself. In this project, only the mechanism for the food container is presented, as it would be identical to the water container, as well as the trays.

The LCD in the smart pet feeder shows current time, together with the current weight of food inside the container and the [69]current temperature around the smart pet feeder. The food weight is measured using the force sensor as the replacement of the weight sensor which is not available in Tinkercad. The food could be released manually as well using the button in the smart pet feeder. As can be seen from Fig. 8, the force sensor is connected to the A0 pin using orange wire. This connection shows that Arduino would take analog signals from the force sensor as an input. The system is designed to notify pet owners when the weight of the food is less or equal to 100 gram. Pet owners would be notified via the mobile app as well as the LED and piezo buzzer that would

turn on when the weight of food reaches 100 gram. Similar to the force sensor, the temperature sensor is connected to the analog pin of the Arduino board, which is pin A2 using green wire. Fig. 9 shows the system when the weight of the food is less than 100 grams. It could be seen that the LED and piezo buzzer are turned on. Fig 9 LED and piezo buzzer turned on when food weight is less than or equal to 100 grams



**FIGURE 9** LED and piezo buzzer turned on when food weight is less than or equal to 100 grams

To handle the food releasing, a servo motor is used to open or close the lid of the container. There are two different ways to open the lid of the container, one via the mobile app, and the other one is using the button available in the smart pet feeder. The lid would be opened for 2 seconds before automatically closing again. Both the button and servo motor are connected to the Arduino via the digital pins 7 (grey wire) and 8 (white wire) respectively, and they would have only two different states. The button would be in state 0 when not pressed and state 1 when pressed, and the servo motor would be in state 0 when closed and state 1 when opened. The presence of a PIR sensor serves the purpose of detecting movement of the pets. Together with the camera (not implemented in Tinkercad), it would allow pet owners to be more aware of their pets. Pet owners would be notified when their pets are around the smart pet feeder, then, they could check the environment via the camera. The PIR sensor is connected to the digital pin 9, which

means it would have two states, 0 for no object presence and 1 for object presence.

Aside from the button to open the container lid manually, there are four different buttons attached to set the time and feeding schedule [70]. The first button is used to set the time of the clock that would be shown in the LCD. Another function is it could be used to bring the pet owners to the main state, which shows the clock, weight of food, as well as temperature after setting the time or alarm. Second button is used to set the first feeding schedule, and could then be used to increase the time, be it the hour, minute, or second. The third button serves a similar function as the second button, where it is used to set the second feeding schedule, and then to move the setting from hour to minute, minute to second, and second to hour iteratively. The fourth button would be useful setting the third feeding schedule.

### Mobile App Prototype

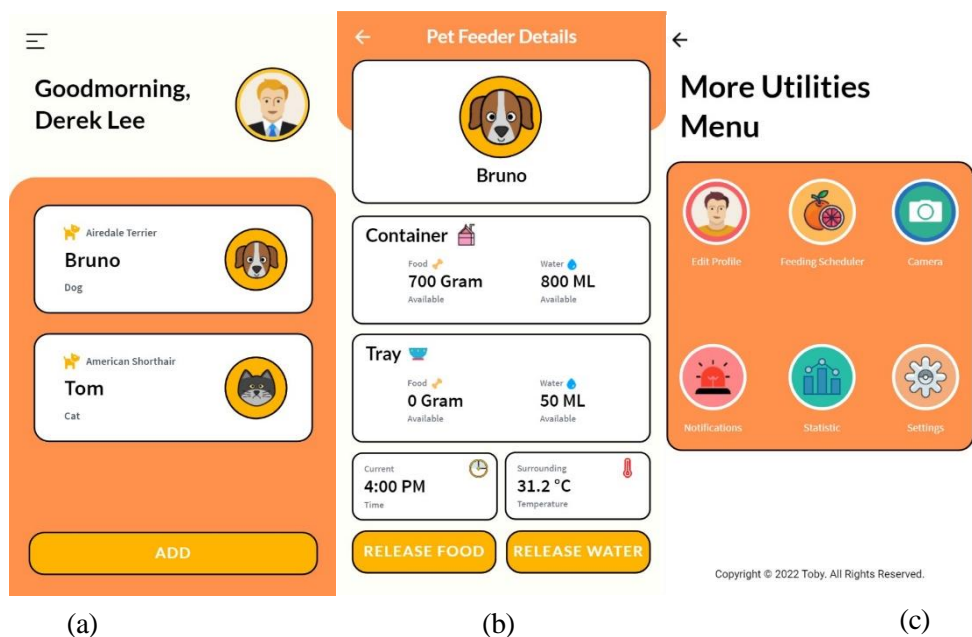

**FIGURE 10** (a) Main Page. (b) Pet Details Page.  
(c) Utility Page

Fig. 10 shows the prototype of the mobile app 'Toby' which was designed using the Marvel app. The mobile app is developed to serve the purpose of being a media for pet owners to control the smart pet feeder remotely when they do not have physical access to the smart pet feeder. Every function of the smart pet feeder is usable using the mobile app, which are automatic feeding, monitoring using camera, real-time interaction with the microphone and speaker, notification, and historical data report. Fig. 9(a) shows the main page of the mobile app, where an account could have multiple smart pet feeders connected to it. Fig. 9(b) shows the details of one smart pet feeder, where pet owners could see the information of the current food and water amount in both container and tray, as well as the clock and current temperature. Other functions in Fig. 9(c) which are profile editing, feeding scheduling, camera and

microphone, notification, historical data report, and settings are accessible via the button located on the top left side of Fig. 10(a).

## 5. DISCUSSION

The smart pet feeder has several strengths due to the fact that it has a dedicated mobile app. The dedicated mobile app has provided users with great conveniences. One of the strengths is that the users can view the amount of food and water left in both the container and the tray of the smart pet feeder as the smart pet feeder is integrated with the sensor that can detect the remaining food and water in the containers and trays. Not only that, but the mobile app will notify the users via push notification when the amount of food and water is low. Hence, the users can refill the food and water accordingly. In addition, the smart pet feeder is designed to be automated such that the users can utilise the mobile app to release the food and water to the tray as the mobile app is linked to the smart pet feeder. More importantly, the users can add the feeding schedule via the mobile app and set the amount of food and water to be released each time [71]. Then, the food and the water will be released automatically according to that schedule. Hence, the users can avoid overfeeding their pets.

Integrated sensors in the smart pet feeder will display the surrounding temperature of the smart pet feeder via the mobile app. As a result, the users will be aware of the temperature and they can take the necessary action if the temperature is too high. It is because pet food will be adversely affected if it is stored at a high temperature for a long time. For instance, the vitamins in the food will be damaged [38]. Furthermore, the main functions are accessible not only via the mobile app, thus, but pet owners also have the flexibility to use only the smart pet feeder without needing to register for an account.

### 5.1 Weaknesses

On the other side of the coin, the smart pet feeder does have several weaknesses. Since it is an automated pet feeder, it requires electricity to

operate. However, there is only one emergency battery which will be used only when an emergency like a blackout happens. With that being said, the smart pet feeder has to be placed at a location where there is a power socket nearby, and it has to be plugged all the time so that it can operate and send the necessary information to the dedicated mobile app. This might cause minor inconveniences to the users. Apart from that, since the smart pet feeder has to be connected to the power supply, the sensors that are integrated with the smart pet feeder might be damaged once a short circuit happens. Once the sensor is damaged, no information will be collected, and hence, there will be no data displayed on the mobile app. Worse still, the damage to the sensor might cause the smart pet feeder to operate less smoothly. Moreover, if the sensor is damaged, the user has to send it to be repaired, which will be an additional cost for the users.

Besides, the dedicated mobile app and the smart pet feeder might be vulnerable to hackers. The dedicated mobile app will collect the personal data of the users. Then, the data will be stored in the cloud. However, when the data is sent to the cloud, there is a lack of encryption which causes it to be vulnerable to hackers. Worse still, since the mobile app is connected to the smart pet feeder, once the hackers get control over the mobile app, they might get control of the smart pet feeder easily.

### 5.2 Limitations

There are several known constraints for the smart pet feeder. One of the constraints is that the pet feeder and the mobile phones of the users have to be connected to the internet so that the data can be transferred from the pet feeder to the mobile app and vice versa. Without an internet connection, no data can be transferred and the users will lose remote access to the pet feeder.

In addition, the battery in the pet feeder is for emergency purposes only such as a blackout. In fact, the pet feeder has to be connected to the power supply at all times in order for it to operate. With that being said, the pet feeder has



to be placed near the power socket but not anywhere. Moreover, since the power consumption of the pet feeder is high, if the emergency battery is being used, the emergency battery will drain in a short time.

Furthermore, another known issue is that since the pet feeder has to be connected to the power supply, the cable might be damaged as it might be scratched or bitten by the pets. If the cable is damaged, it will become a safety hazard for the users and the pets. Besides, the water in the tray might be accidentally spilt. It will cause electrocution and a fire threat.

Apart from that, each pet feeder can only be used for one pet. With that being said, if the pet owner has more than one pet, the pet owner has to purchase the same amount of the smart pet feeder. Although the users can control all the pet feeders using one device, the user would still have to manually access each and every pet feeder via the mobile app.

## 6. CONCLUSION AND FUTURE WORK

The Internet of Things (IoT) is widely regarded as one of the most promising technologies, having the potential to grow in popularity and usage in the near future. In 2022, it is expected that the market size of IoT will reach USD 594 billion [43]. Even in its current state, the potential of IoT is astounding, and the advantages are alluring. It provides several chances to improve the quality of our lives.

In a nutshell, whereas people crave freedom in the aftermath of a pandemic, our pets thrive on consistency and habit, therefore an automated smart pet feeder powered by IoT technology might be the ultimate solution. The smart pet feeder, compared to a traditional gravity bin feeder, offers great conveniences to the users in many ways by utilising the sensors integrated with it, making life easier for busy people. Furthermore, as the dedicated mobile app is compatible with various smartphone platforms, it has brought additional convenience to customers where the users can access and monitor the pet feeder via the mobile app as the crucial information collected from the pet feeder will be sent to the mobile app and vice versa, and all the data will be synchronised in

real-time.

As the smart pet feeder depends only on the Wi-Fi connection, the implementation of 4G or 5G connection could be considered to improve the efficiency of the device. By adding 4G or 5G connection, pet owners would be enabled to control their smart pet feeders even though the electricity is down and the Wi-Fi router is turned off. Currently, the smart pet feeder relies heavily on electricity, as it could only be controlled remotely with the presence of Wi-Fi connection. The camera function could be improved as in by adding the function of recording playback, which allows pet owners to rewatch the recording of the camera. However, by adding this function, more factors such as security and storage should be considered as well, as it will increase the usage of the storage in the cloud, and the recording data would be prone to security attacks. The solution could be by offering paid cloud storage or adding a slot for a memory card for the smart pet feeder to save the recording internally. A lot of improvement could be made on the security factor as well, as this device is connected to the open internet. Since Arduino does not have any built-in firewalls, multiple firewalls could be added to every layer of the architecture. The implementation of ethernet shields such as the WIZ550io module could be considered as well, however this solution requires higher cost. From the experiment performed by a user 'i\_am\_maker\_leo' posted in Instructable Circuits, the implementation of ethernet shield WIZ550io could increase the security of the Arduino board and prevent it from DDOS attack [39].

The global data is predicted to grow to more than 180 zettabytes by 2025, where 1 zettabyte is equal to 1 million terabytes of data [40]. With the assumption that the number of users are growing, the data generated would increase proportionally. Higher bandwidth would allow higher data transfer rate, thus, by increasing the bandwidth, the efficiency of the system would increase simultaneously [41].

## REFERENCES

- Quiñonez, Y., Lizarraga, C., Aguayo, R., & Arredondo, D. (2021). Communication architecture based on IoT technology to control and monitor pets feeding. *JUCS - Journal of Universal Computer Science*, 27(2). <https://doi.org/10.3897/jucs.65094>
- SSLA. (n.d.). What is arduino? What are the advantages of Arduino? | [ssla.co.uk](https://www.ssla.co.uk). Retrieved January 15, 2022, from <https://www.ssla.co.uk/arduino/>
- Hübschmann, I. (2020, September 17). Is the ESP8266 WiFi Module the Right Choice for You? Nabto. Retrieved January 15, 2022, from <https://www.nabto.com/is-esp8266-wifi-module-right-choice-for-you/>
- Hakim, M. A., Husna, N., & Nurfatin. (2020, June). SMART PET FEEDER. Institutional Repository at Politeknik Sultan Salahuddin Abdul Aziz Shah. <http://repository.psa.edu.my/handle/123456789/3155>
- Tech Explorations. (n.d.). 1. What is Blynk? Retrieved January 15, 2022, from <https://techexplorations.com/guides/blynk/1-what-is-blynk/#:~:text=Blynk%20is%20a%20robust%20and,garage%20door%2C%20with%20your%20phone.>
- mydlink: Watch what matters. (n.d.). Mydlink. Retrieved January 15, 2022, from <https://id.mydlink.com/content/productfamily#49tabM99>
- Blynk. (n.d.). Blynk. Retrieved January 15, 2022, from <https://docs.blynk.cc/#security-use-local-blynk-server>
- Chen, Y., & Elshakankiri, M. (2020). Implementation of an IoT based Pet Care System. 2020 Fifth International Conference on Fog and Mobile Edge Computing (FMEC). <https://doi.org/10.1109/FMEC49853.2020.9144910>
- Wain, S. (2019, December 30). How Technology Has Changed In The Last 20 Years. MyMemory Blog. Retrieved January 15, 2022, from <https://www.mymemory.co.uk/blog/how-technology-has-changed-in-the-last-20-years/>
- Hughes, L. (2017, September 11). Single Board Computers: Uses, Prototypes & Getting to Market Faster. Arrow. Retrieved January 15, 2022, from <https://www.arrow.com/en/research-and-events/articles/how-single-board-computers-getyou-to-market-faster>
- Pounder, L. (2020, July 11). Raspberry Pi vs Arduino: Which Board is Best? Tom's Hardware. Retrieved January 15, 2022, from <https://www.tomshardware.com/uk/features/raspberry-pi-vs-arduino>
- Klosowski, T. (2021, November 5). Why We Love the Raspberry Pi. Wirecutter: Reviews for the Real World. Retrieved January 15, 2022, from <https://www.nytimes.com/wirecutter/reviews/raspberry-pi/>
- Laserlicht. (2019, July 3). Raspberry Pi 4 Model B [Image]. Wikimedia Commons. [https://commons.wikimedia.org/wiki/File:Raspberry\\_Pi\\_4\\_Model\\_B\\_-\\_Side.jpg](https://commons.wikimedia.org/wiki/File:Raspberry_Pi_4_Model_B_-_Side.jpg)
- Arduino UNO R3. (n.d.). [Image]. ElectroPeak. <https://electropeak.com/arduino-uno-r3-clone>
- di Justo, P. (2015, December 4). Raspberry Pi or Arduino Uno? One Simple Rule to Choose the Right Board. Make: DIY Projects and Ideas for Makers. Retrieved January 17, 2022, from <https://makezine.com/2015/12/04/admittedly-simplistic-guide-raspberry-pi-vs-arduino/>
- Vineeth, S., Renukumar, B. R., Sneha, V. C., Rani, B., & Ganjihal, P. (2020). Automatic Pet Food Dispenser using Digital Image Processing. *International Journal of Engineering Research and Technology*, 9(5). <https://doi.org/10.17577/ijertv9is050513>
- Ibrahim, M., Zakaria, H., & Xian, E. W. (2019). Pet food autofeeder by using Arduino. IOP Conference Series:

- Materials Science and Engineering, 670(1). <https://doi.org/10.1088/1757-899x/670/1/012069>
18. Gainesville Industrial Electric Co. (n.d.). AC and DC Motors: Differences and Advantages | Types of Electric Motors. Retrieved January 15, 2022, from <https://www.gainesvilleindustrial.com/blog/ac-dc-motors/>
  19. George, A. (2020, January 28). A Quick Guide to the Differences Between Arduino vs. Raspberry Pi Boards. Lifewire. Retrieved January 15, 2022, from <https://www.lifewire.com/arduino-vs-raspberry-pi-4780279>
  20. Low Orbit Flux. (n.d.). How Long Can A Raspberry Pi Run On Batteries | Low Orbit Flux. Retrieved January 15, 2022, from <https://low-orbit.net/how-long-can-a-raspberry-pi-run-on-batteries>
  21. Hughes, L. (2016, June 20). How to Power a Raspberry Pi with Batteries. Arrow. Retrieved January 17, 2020, from <https://www.arrow.com/en/research-and-events/articles/battery-power-your-pi>
  22. TECHDesign. (2017, February 6). 8 Reasons Why ESP8266 has Been So Popular. TECHDesign Blog. Retrieved January 18, 2022, from <https://blog.techdesign.com/8-reasons-esp8266-popular/>
  23. Santos, R. (2021, May 31). Best ESP8266 Wi-Fi Development Board – Buying Guide 2021. Maker Advisor. Retrieved January 18, 2022, from <https://makeradvisor.com/best-esp8266-wi-fi-development-board/>
  24. Elmer, J. (2020, January 8). Classical Conditioning and How It Relates to Pavlov's Dog. Healthline. Retrieved January 17, 2022, from <https://www.healthline.com/health/classical-conditioning>
  25. Poddiachyi, A. (2020, January 9). Reinforcement learning, Psychology, Conditioning | Towards Data Science. Medium. Retrieved January 17, 2022, from <https://towardsdatascience.com/reinforcement-learning-brain-and-psychology-part-2-classical-and-instrumental-conditioning-217a4f0a989>
  26. Pallavi, S., & Smruti, R. S. (2017). Internet of Things: Architectures, Protocols, and Applications. Journal of Electrical and Computer Engineering. <https://doi.org/10.1155/2017/9324035>
  27. Jena, S. (2020, June 25). Data Link Layer Communication Protocols in IoT. GeeksforGeeks. Retrieved January 19, 2022, from <https://www.geeksforgeeks.org/data-link-layer-communication-protocols-in-iot/>
  28. Devasena, C. L. (2016). IPv6 Low Power Wireless Personal Area Network (6LoWPAN) for Networking Internet of Things (IoT) – Analyzing its Suitability for IoT. Indian Journal of Science and Technology, 9(30).
  29. GeeksforGeeks. (2022, January 12). Layers of OSI Model. Retrieved January 19, 2022, from <https://www.geeksforgeeks.org/layers-of-osi-model/>
  30. Al-Masri, E., Kalyanam, K. R., Batts, J., Kim, J., Singh, S., Vo, T., & Yan, C. (2020). Investigating Messaging Protocols for the Internet of Things (IoT). IEEE Access. <https://doi.org/10.1109/access.2020.2993363>
  31. StudyTonight. (n.d.). Transport Layer of OSI Reference Model | Studytonight. Retrieved January 19, 2022, from <https://www.studytonight.com/computer-networks/osi-model-transport-layer>
  32. Bonello, S. (2021, February 5). Is Java a dying language? Chubby Developer. Retrieved February 13, 2022, from <https://www.chubbydeveloper.com/is-java-a-dying-language/>
  33. Kassab, W., & Darabkh, K. A. (2020). A-Z survey of Internet of Things: Architectures, protocols, applications, recent advances, future directions and recommendations. Journal of Network and Computer Applications, 163. <https://doi.org/10.1016/j.jnca.2020.102663>
  34. Wayner, P. (2021, August 9). What is

- Firestore? VentureBeat. Retrieved February 13, 2022, from <https://venturebeat.com/2021/08/02/what-is-firebase/>
35. Stevenson, D. (2018, September 25). What is Firebase? The complete story, abridged. - Firebase Developers. Medium. Retrieved February 13, 2022, from <https://medium.com/firebase-developers/what-is-firebase-the-complete-story-abridged-bcc730c5f2c0>
  36. Firebase Realtime Database | Firebase Documentation. (n.d.). Firebase. Retrieved February 13, 2022, from <https://firebase.google.com/docs/database>
  37. Tran, Q., Hendriks, W., & van der Poel, A. (2011). Effects of drying temperature and time of a canine diet extruded with a 4 or 8mm die on physical and nutritional quality indicators. *Animal Feed Science and Technology*, 165(3–4), 258–264. <https://doi.org/10.1016/j.anifeedsci.2011.03.009>
  38. I\_Am\_Maker\_Leo. (n.d.). How to Make Unattackable Secure Arduino IoT Device. Instructable Circuits. Retrieved February 10, 2022, from <https://www.instructables.com/How-to-make-unattackable-secure-arduino-IoT-device/>
  39. von See, A. (2021, June 7). Volume of data/information created, captured, copied, and consumed worldwide from 2010 to 2025. Statista. Retrieved February 13, 2022, from <https://www.statista.com/statistics/871513/worldwide-data-created/#:%7E:text=The%20total%20amount%20of%20data,to%20more%20than%20180%20zettabytes.>
  40. IMDA Singapore. (2019, May 13). Benefits of Higher Bandwidth. Infocomm Media Development Authority Singapore. Retrieved February 13, 2022, from [https://www.imda.gov.sg/for-community/connectivity-guides/mobile-and-broadband/benefits-of-higher-bandwidth](https://www.imda.gov.sg/for-community/connectivity-guides/mobile-and-broadband/benefits-of-higher-bandwidth#:~:text=Shorter%20Download%20Time-,Having%20a%20higher%20bandwidth%20means%20you%20will%20be%20able%20to,significant%20when%20downloading%20large%20files.)
  41. Oladele, A. (2022, February 1). Top IoT Market Demands: Internet of Things Forecasts 2022. Velvetech. <https://www.velvetech.com/blog/top-iot-market-demands/#iot-market-size>
  42. Ali, S., Hafeez, Y., Jhanjhi, N. Z., Humayun, M., Imran, M., Nayyar, A., ... & Ra, I. H. (2020). Towards pattern-based change verification framework for cloud-enabled healthcare component-based. *Ieee Access*, 8, 148007-148020.
  43. Khan, N. A., Brohi, S. N., & Jhanjhi, N. Z. (2020). UAV's applications, architecture, security issues and attack scenarios: A survey. In *Intelligent Computing and Innovation on Data Science: Proceedings of ICTIDS 2019* (pp. 753-760). Springer Singapore.
  44. Zaman, N., Low, T. J., & Alghamdi, T. (2014, February). Energy efficient routing protocol for wireless sensor network. In *16th international conference on advanced communication technology* (pp. 808-814). IEEE
  45. Gaur, L., Afaq, A., Solanki, A., Singh, G., Sharma, S., Jhanjhi, N. Z., ... & Le, D. N. (2021). Capitalizing on big data and revolutionary 5G technology: Extracting and visualizing ratings and reviews of global chain hotels. *Computers and Electrical Engineering*, 95, 107374.
  46. Diwaker, C., Tomar, P., Solanki, A., Nayyar, A., Jhanjhi, N. Z., Abdullah, A., & Supramaniam, M. (2019). A new model for predicting component-based software reliability using soft computing. *IEEE Access*, 7, 147191-147203.
  47. Sennan, S., Somula, R., Luhach, A. K., Deverajan, G. G., Alnumay, W., Jhanjhi, N. Z., ... & Sharma, P. (2021). Energy efficient optimal parent selection based routing protocol for Internet of Things using firefly optimization

- algorithm. *Transactions on Emerging Telecommunications Technologies*, 32(8), e4171.
48. Hussain, S. J., Ahmed, U., Liaquat, H., Mir, S., Jhanjhi, N. Z., & Humayun, M. (2019, April). IMIAD: intelligent malware identification for android platform. In *2019 International Conference on Computer and Information Sciences (ICCIS)* (pp. 1-6). IEEE.
  49. Shafiq, M., Ashraf, H., Ullah, A., Masud, M., Azeem, M., Jhanjhi, N., & Humayun, M. (2021). Robust cluster-based routing protocol for IoT-assisted smart devices in WSN. *Computers, Materials & Continua*, 67(3), 3505-3521. ]23\ [https://www.researchgate.net/publication/233823923\\_Traffic\\_Monitoring\\_Using\\_M2M\\_CommunicationM2M\\_tongsineul\\_sayonghan\\_teulaepig\\_moniteoling/figures?lo=1](https://www.researchgate.net/publication/233823923_Traffic_Monitoring_Using_M2M_CommunicationM2M_tongsineul_sayonghan_teulaepig_moniteoling/figures?lo=1)
  50. Adeyemo, V. E., Abdullah, A., Jhanjhi, N. Z., Supramaniam, M., & Balogun, A. O. (2019). Ensemble and deep-learning methods for two-class and multi-attack anomaly intrusion detection: An empirical study. *International Journal of Advanced Computer Science and Applications*, 10(9) doi:<https://doi.org/10.14569/IJACSA.2019.0100969>
  51. Gaur, L., Singh, G., Solanki, A., Jhanjhi, N. Z., Bhatia, U., Sharma, S., ... & Kim, W. (2021). Disposition of youth in predicting sustainable development goals using the neuro-fuzzy and random forest algorithms. *Human-Centric Computing and Information Sciences*, 11, NA.
  52. Lim, M., Abdullah, A., & Jhanjhi, N. Z. (2021). Performance optimization of criminal network hidden link prediction model with deep reinforcement learning. *Journal of King Saud University-Computer and Information Sciences*, 33(10), 1202-1210.
  53. Hussain, K., Hussain, S. J., Jhanjhi, N. Z., & Humayun, M. (2019, April). SYN flood attack detection based on bayes estimator (SFADBE) for MANET. In *2019 International Conference on Computer and Information Sciences (ICCIS)* (pp. 1-4). IEEE.
  54. Srinivasan, K., Garg, L., Datta, D., Alaboudi, A. A., Jhanjhi, N. Z., Agarwal, R., & Thomas, A. G. (2021). Performance comparison of deep cnn models for detecting driver's distraction. *CMC-Computers, Materials & Continua*, 68(3), 4109-4124.
  55. Muhammad Ibrahim Khalil, N.Z. Jhanjhi, Mamoona Humayun, SivaKumar Sivanesan, Mehedi Masud, M. Shamim Hossain, Hybrid smart grid with sustainable energy efficient resources for smart cities, Sustainable Energy Technologies and Assessments, Volume 46, 2021, 101211, ISSN 2213-1388, <https://doi.org/10.1016/j.seta.2021.101211>
  56. A. Almusaylim, Z., Jhanjhi, N. Z., & Alhumam, A. (2020). Detection and mitigation of RPL rank and version number attacks in the internet of things: SRPL-RP. *Sensors*, 20(21), 5997.
  57. Lim, M., Abdullah, A., Jhanjhi, N. Z., & Supramaniam, M. (2019). Hidden link prediction in criminal networks using the deep reinforcement learning technique. *Computers*, 8(1), 8.
  58. Fatima-tuz-Zahra, N. Jhanjhi, S. N. Brohi and N. A. Malik, "Proposing a Rank and Wormhole Attack Detection Framework using Machine Learning," 2019 13th International Conference on Mathematics, Actuarial Science, Computer Science and Statistics (MACS), Karachi, Pakistan, 2019, pp. 1-9, doi: 10.1109/MACS48846.2019.9024821.
  59. Humayun, M., Jhanjhi, N. Z., Alruwaili, M., Amalathas, S. S., Balasubramanian, V., & Selvaraj, B. (2020). Privacy protection and energy optimization for 5G-aided industrial Internet of Things. *IEEE Access*, 8, 183665-183677.
  60. Lee, S., Abdullah, A., Jhanjhi, N., & Kok, S. (2021). Classification of botnet attacks in IoT smart factory using honeypot combined with machine learning. *PeerJ Computer Science*, 7, e350.

61. Zaman, N., Low, T. J., & Alghamdi, T. (2014, February). Energy efficient routing protocol for wireless sensor network. In *16th international conference on advanced communication technology* (pp. 808-814). IEEE.
62. Khan, N. A., Brohi, S. N., & Jhanjhi, N. Z. (2020). UAV's applications, architecture, security issues and attack scenarios: A survey. In *Intelligent Computing and Innovation on Data Science: Proceedings of ICTIDS 2019* (pp. 753-760). Springer Singapore.
63. Ali, S., Hafeez, Y., Jhanjhi, N. Z., Humayun, M., Imran, M., Nayyar, A., ... & Ra, I. H. (2020). Towards pattern-based change verification framework for cloud-enabled healthcare component-based. *Ieee Access*, 8, 148007-148020.
64. Shah, I. A., Jhanjhi, N. Z., Humayun, M., & Ghosh, U. (2022). Impact of COVID-19 on Higher and Post-secondary Education Systems. In *How COVID-19 is Accelerating the Digital Revolution* (pp. 71-83). Springer, Cham.
65. Shah, I. A., Jhanjhi, N. Z., Amsaad, F., & Razaque, A. (2022). The Role of Cutting-Edge Technologies in Industry 4.0. In *Cyber Security Applications for Industry 4.0* (pp. 97-109). Chapman and Hall/CRC.
66. Shah, I. A. (2022). Cybersecurity Issues and Challenges for E-Government During COVID-19: A Review. *Cybersecurity Measures for E-Government Frameworks*, 187-222.
67. Shah, I. A., Wassan, S., & Usmani, M. H. (2022). E-Government Security and Privacy Issues: Challenges and Preventive Approaches. In *Cybersecurity Measures for E-Government Frameworks* (pp. 61-76). IGI Global.
68. Shah, I. A., Sial, Q., Jhanjhi, N. Z., & Gaur, L. (2023). Use Cases for Digital Twin. In *Digital Twins and Healthcare: Trends, Techniques, and Challenges* (pp. 102-118). IGI Global.
69. Shah, I. A., Jhanjhi, N. Z., & Laraib, A. (2023). Cybersecurity and Blockchain Usage in Contemporary Business. In *Handbook of Research on Cybersecurity Issues and Challenges for Business and FinTech Applications* (pp. 49-64). IGI Global.
70. Shah, I. A., Sial, Q., Jhanjhi, N. Z., & Gaur, L. (2023). The Role of the IoT and Digital Twin in the Healthcare Digitalization Process: IoT and Digital Twin in the Healthcare Digitalization Process. In *Digital Twins and Healthcare: Trends, Techniques, and Challenges* (pp. 20-34). IGI Global.
71. Kiran, S. R. A., Rajper, S., Shaikh, R. A., Shah, I. A., & Danwar, S. H. (2021). Categorization of CVE Based on Vulnerability Software By Using Machine Learning Techniques. *International Journal*, 10(3).