



DURABILITY PROPERTIES OF BASALT FIBER REINFORCED CONCRETE WITH ADDITION OF POLYMER UNDER EFFECT OF ACID ATTACK – AN EXPERIMENTAL STUDY

Raghu M E^{1*}, Anila Kumar C P²

Abstract

In this research work is to study the Durability characteristics of basalt fiber reinforced concrete with addition of polymer under acid environment with various percentage as 0% to 3% with increment of 0.5% by weight of cementations material and 1% of basalt fiber with 12mm length of basalt fiber is throughout random mix constant in concrete. Durability properties were studied on Compressive, split tensile, flexural, shear and impact strength for M30 grade concrete under effect of acidic condition. Specimens were prepared and normal curing for 28 day is adopted. After that all specimens' were kept in acid media at 180days with pH was maintained to be 2.5. Workability decreases with increases the polymer content. The performance of BFRPC was found better than the control concrete. The increases in compressive strength is 40Mpa for 1.5% of Polymer, Split Tensile, Flexural and Shear strength are 4Mpa, 8.46MPa, 20.00Mpa for 2% of Polymer respectively and Impact Strength for 2% of polymer first Crack appears 809.16N-m and Final crack is 926.74. Under the acid media the durability properties of basalt fiber reinforced concrete with addition of polymer are better strength properties with respect to reference concrete.

Keywords: Keyword 1: Durability Keyword 2: Basalt Keyword 3: Polymer Keyword 4: Acid attack
Keyword 5: Study

^{1*}Department of Civil Engineering, Bapuji Institute of Engineering and Technology, Davangere - 577 004, Karnataka, India. raghukakkaragolla@gmail.com

²Department of Civil Engineering, Bapuji Institute of Engineering and Technology, Davangere - 577 004, Karnataka, India, and drbssmg@gmail.com

***Corresponding Author:** Raghu M E

*Department of Civil Engineering, Bapuji Institute of Engineering and Technology, Davangere - 577 004, Karnataka, India. raghukakkaragolla@gmail.com

DOI: 10.53555/ecb/2023.12.Si13.209

1 Introduction

Concrete is a composite materials having high compressive strength but poor in split tensile strength. Presence of fiber in concrete improves the physical properties as well as it acts as crack arresters [2]. Fibers were used in concrete to improve its tensile strength, flexural strength, toughness, impact, abrasion resistant fatigue and durability study. All basalt fiber an inert mineral fiber is gaining more important properties in resistance corrosion and low thermal conductivity [6]. The most commonly used fibers are steel, glass, carbon, polypropylene, polyester, nylon and basalt fibers. The properties of concrete depend on the type of fiber, orientations, geometries and densities. In recent years, basalt fiber in concrete is found to be cost effective having an excellent harden properties than other type of fibers. Basalt is igneous rock is generally found near East Asian countries[6]. Among which Russia has abundant reserves. In India, basalt rocks are found near deccan plateau and basalt fiber in concrete performs good tensile, flexural strength, young's modulus and stiffness to the concrete and better acid resistance than the alkaline solution [4]. Basalt fibers also have excellent insulating properties, resistance to heat chemicals to the other fibers. Basalt fiber is a ceramic fiber is dispersed easily when mixed in concrete. The cost of the basalt fiber is relatively higher than other fibers. Basalt fiber is more stable than organic and synthetic fibers. In early 1980s the research on and development of basalt fiber and its composites were started. But in the last few years there is extensive research on mechanical properties and durability study on basalt fiber reinforced concrete (BFRC). It is found that basalt fibre possess relatively good resistance to water and salt corrosion, moderate resistance to acid corrosion in an alkaline environment [17].

2 Experimental Program

2.1 Materials

The Binding material of Ultra Tech 43 grade OPC were used for the mixes and casting of all the specimens. The specific gravity and water absorption of fine aggregate is 2.6 and 2% respectively, it was confirming to Zone II as per IS 383 -2016 [24].The maximum size of coarse aggregate used here is below 20mm. Specific gravity and water absorption of coarse aggregates are 2.72 and 0.61% as per IS 383-2016 [24]. Both coarse and fine aggregate used here is in surface dry condition. Chopped basalt fiber is procured from akurli industrial estate, Mumbai, with a length of 12mm and randomly distributed fibers

were used in the concrete mix. Styrene butadiene rubber latex polymer is used in this work. The quantity of polymer used in the experimentations is 0% to 3% by weight of cementitious materials with an increment of 0.5%. Specific gravity of polymer is 1.02 with white colour. Conplast SP430 is used as a superplasticizer. Portable water is used for the preparation of concrete specimens and curing is used. Hydrochloric acid (HCL) solution with pH is 2.5 was regularly maintained in the present work.

2.2 Mix Design

The design mix procedure used in the present research work & to make M30 grade concrete as per the guidelines of IS 10262-2016 [23]. Mix proportion ratio is 1: 1.96: 3.59:0.44

2.3 Casting procedure of concrete specimen

The concrete mix proportion used in this research work is 1: 1.96: 3.59. This is obtained by mixing cement: fine aggregate: coarse aggregate which is obtained for M30 grade concrete mix proportion [17]. For a total volume of concrete, 1% of basalt fibers are added in all these mixes. Homogenous dry mixing is done for all these ingredients. Water is added as per the calculations $W/CM = 0.44$ for all the mixes and 1% of superplasticizer was added by weight of cementitious materials. At this point polymer is added into the system as per calculations from 0 to 3% with an increment of 0.5% by weight of cementitious materials. Freshly prepared mix concrete was poured into the moulds and they were compacted by using tamping rod in three layers and also with vibrators. All the specimens were removed from the table vibrators. All the specimens were taken out of the mould after 24 hours and they were kept in curing tank and allowed for different curing periods for durability tests [18]. For each of the mix designation, three specimens were casted for different tests. All the specimens were taken out of the mould after 24 hours and they were kept in curing tank they will under curing for the 28days period. Acid media having pH 2.5 was prepared separately using hydrochloric acid and after 28days of normal curing, all the specimens were kept in that acidic media for 180 days. To determine compressive strength, tensile strength, flexural strength, shear strength and impact strength of three specimens for each mix were casted. They were tested once the specimen completes the curing procedure [19].

3. Test Result and discussion

3.1 Fresh properties

Fresh properties of concrete can be determined by using workability test with respect to slump cone and compaction factor. Table 3.1 gives the slump cone and compaction factor test values for basalt fiber reinforced concrete with addition of different percentage of polymer in it. The results obtained from workability test clearly mention that

increases the polymer content it decreases the workability. From the result of slump cone test, it is noticed that addition of 1.5% polymer in concrete will lead to collapsible slump and it will continue till 3% polymer addition. From the experimental results is observed that there is gradual decreases in the slump with an increase an increases basalt fiber.

Table 3.1: Slump cone and compaction factor test for basalt fiber reinforced concrete with addition of polymer

Percentage of Polymer	Slump value	Compaction factor
0	100	0.98
0.5	95	0.97
1.0	80	0.96
1.5	Collapsible Slump	0.96
2.0	Collapsible Slump	0.95
2.5	Collapsible Slump	0.94
3.0	Collapsible Slump	0.93

3.2 Durability Properties of Concrete under acid Attack

3.3.1 Compressive strength test results of Acid attack

Compressive strength of concrete for cube with a size of 150mm×150mm×150mm specimen was

prepared. The compressive strength tests were carried out as per IS 516-1999 [21] on concrete cubes in universal compression testing machine with a capacity of 3000kN.

Table 3.2: Compressive Strength test for acid attack

Mix proportion	Percentage of Polymer	Compressive Strength (Mpa)
A	0	30.36
B	0.5	32.59
C	1.0	34.67
D	1.5	40.00
E	2.0	34.51
F	2.5	27.11
G	3.0	25.03

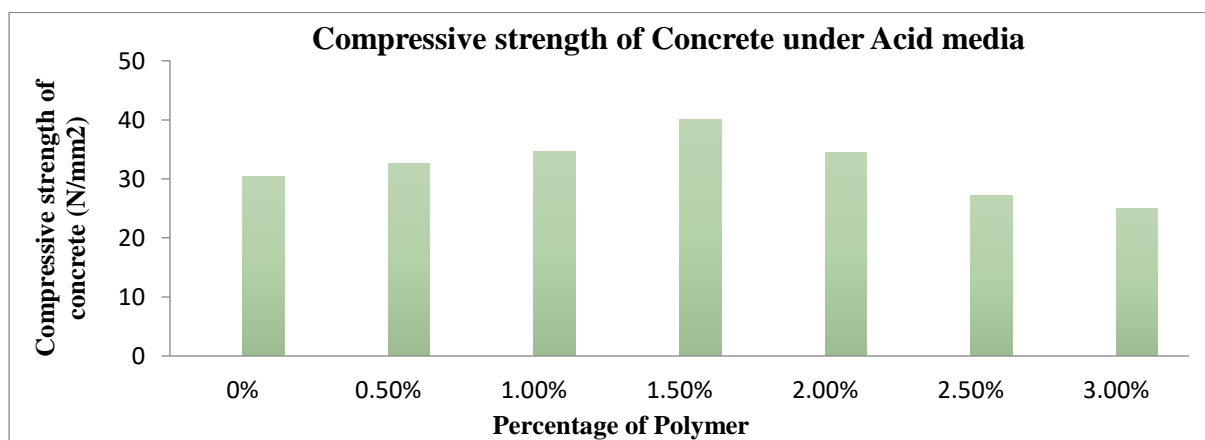

Fig. 3.1: BFRPC Compressive Strength test for acid attack

Compressive strength test results shows that the addition of polymer to BFRP Concrete maintained
Eur. Chem. Bull. **2023**, 12(Special Issue 13), 1192–1199

a pH of 2.5 for 180 days when subjected to acid attack. Percentage of polymer increases and its

compressive strength also increases. When compared to the concrete's reference mix, Mix D, which contains 1.5% polymer and 1% basalt fiber, achieves the highest compressive strength of any of the other mixes by 31.75%. Nevertheless, the requirements for the pioneer stage compressive strength (> 20 MPa) and lost stage compressive strength (> 40 MPa at 28 days and 90 days) of maximum performance concrete [14] were fulfilled for all high performance self-compacting concretes. When 1.5% polymer is added to BFRP

concrete, the compressive strength also increases, reaching its maximum value when the reference mix compressive strength is decreased [17].

3.1.2 Split Tensile strength test results of acid attack

Split tensile strength of concrete for cylinder with a size of 150mm×500mm specimen was prepared. The tensile strength tests were carried out as per IS 5816-1999[21] on concrete cylinder in universal compression testing machine with a capacity of 3000kN.

Table: 3.3 Split Tensile Strength test for acid attack

Mix proportion	Percentage of Polymer	Split Tensile Strength (Mpa)
A	0	3.06
B	0.5	3.43
C	1.0	3.62
D	1.5	3.67
E	2.0	4.00
F	2.5	2.44
G	3.0	2.16

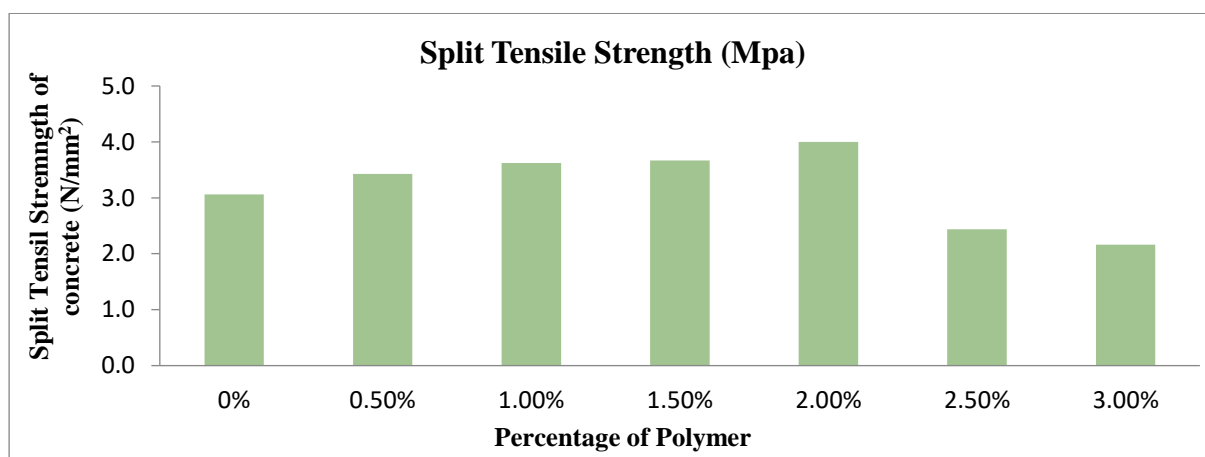

Fig. 3.2: BFRPC Split Tensile Strength test for acid attack

Split tensile strength test results shows that the addition of polymer to BFRP Concrete maintained a pH of 2.5 for 180 days when subjected to acid attack. Muhit et al. [15] reported the effect by adopting quarry dust as partial replacement of cement and sand on the crushing and tensile strengths of concrete material. They found a positive improvement in these strength characteristics over the control mix. Percentage of polymer increases and its split tensile strength also increases. When compared to the concrete's reference mix, Mix E, which 2.0% polymer and 1% basalt fiber, achieves the highest Split tensile strength of any of the other mixes by 30.91%.

When 2.0% polymer is added to BFRP concrete, the split tensile strength also increases, reaching its maximum value when the reference mix split tensile strength is decreased [19].

3.1.3 Flexural strength test results of acid attack

Flexural strength of concrete for beam with a size of 100mm×100mm×500mm specimen was prepared. The Flexural strength tests were carried out as per IS 516-1959 [22] on concrete beam under two point loading for effective span of 400mm.

Table: 3.4 Flexural Strength test for acid attack

Mix proportion	Percentage of Polymer	Flexural Strength (Mpa)
A	0	6.20
B	0.5	6.80
C	1.0	7.06
D	1.5	7.33
E	2.0	8.46
F	2.5	4.13
G	3.0	3.60

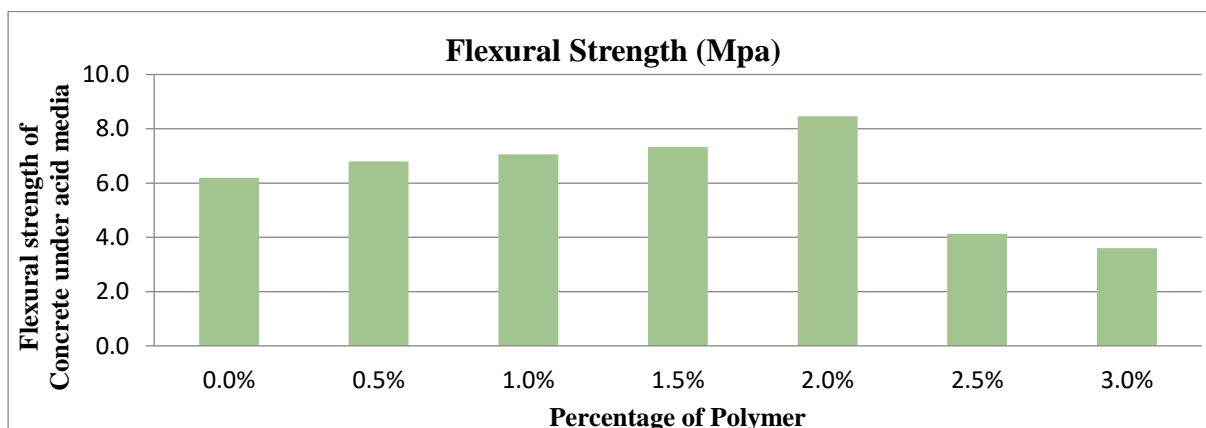

Fig. 3.3: BFRPC Flexural Strength test for acid attack

Flexural strength test results shows that the addition of polymer to BFRP Concrete maintained a pH of 2.5 for 180 days when subjected to acid attack. Percentage of polymer increases and its Flexural strength also increases [19]. When compared to the concrete's reference mix, Mix E, which 2.0% polymer and 1% basalt fiber, achieves the highest Flexural strength of any of the other mixes by 36.51%. The concretes of electrical resistivity maximum are 10 kΩ/cm exhibits less chloride ion permeability and reduction in corrosion rate [16]. When 2.0% polymer is added to BFRP concrete, the Flexural strength also increases, reaching its maximum value when the reference mix Flexural strength is decreased.

3.1.4 Shear strength test results of acid attack

To conduct shear strength of concrete by using L shaped specimens were casted. The specimens were tested in compression testing machine of capacity is 3000kN. Where shear force is applied (150mm × 60mm) [10].

$$\text{Failure load (F)} = P_{11} / (l_1 + l_2)$$

Where, P = Maximum load carried by the specimen in kN

$$l_1 = 25\text{mm} \ \& \ l_2 = 25\text{mm}$$

The shear strength can be calculated by using this equation

$$\text{Shear Strength} = F / A$$

Where, F = Failure load, N. A = Area of cross section

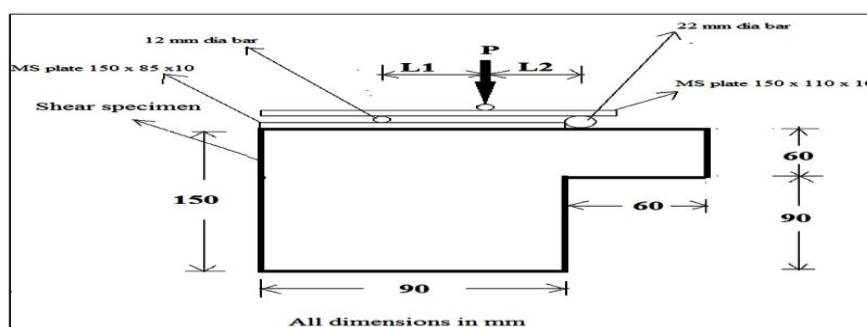

Fig. 3.4: Diagrammatic representation of L shaped shear specimen

Shear strength test results of BFRPC which contains different percentage of polymer. When they are subjected to acid attack of pH is 2.5 [16].

the total age of concrete is 208 days (28 days of normal curing and 180days acid solution curing) is as shown in table 3.5.

Table 3.5: Shear Strength test for acid attack

Mix proportion	Percentage of Polymer	Shear Strength (Mpa)
A	0	12.59
B	0.5	14.82
C	1.0	17.22
D	1.5	18.34
E	2.0	20.00
F	2.5	16.67
G	3.0	12.41

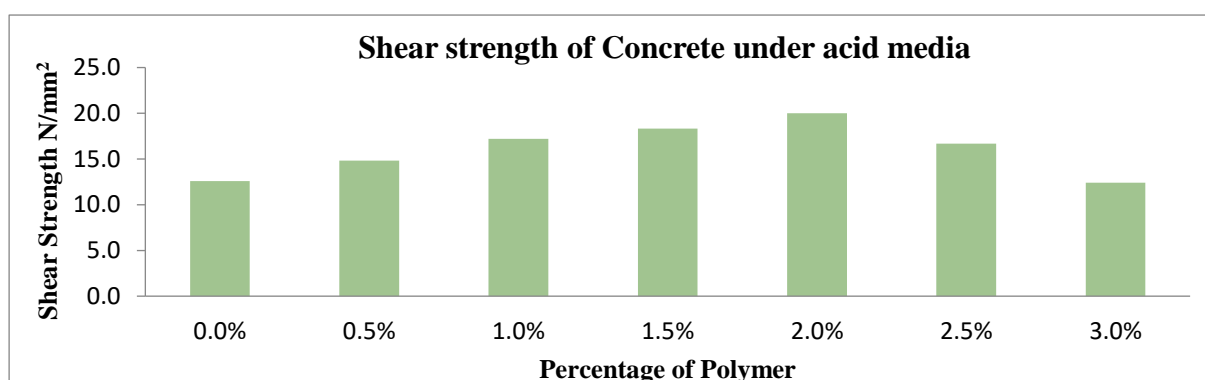

Fig. 3.5: BFRPC Shear Strength test for acid attack

Shear strength test results shows that the addition of polymer to BFRP Concrete maintained a pH of 2.5 for 180 days when subjected to acid attack. Percentage of polymer increases and its Shear strength also increases. When compared to the concrete's reference mix, Mix E, which 2.0% polymer and 1% basalt fiber, achieves the highest Shear strength of any of the other mixes 58.9%. When 2.0% polymer is added to BFRP concrete, the Shear strength also increases, reaching its maximum value when the reference mix shear strength is decreased.

3.1.5 Impact strength test results of acid attack experiment

To conduct impact strength of concrete cylindrical specimens were casted of dimensions 150 mm

diameter and 60mm height. Schrader's impact testing machine was used to conduct the test [16]. First crack appearance and final crack appearance on the concrete specimens were observed and the number of blows at which these cracks appear are recorded. Following is the equation used to calculate impact energy which is done with the help of number of blows [11].

$$\text{Impact energy} = m \times g \times h \times n$$

$$= w/g \times g \times h \times n$$

$$= w \times h \times n$$

Where, w = weight of the hammer = 4.54 kg = 45.4 N

h = height of the fall = 45.7cm = 0.457 m n = number of blows required to cause first cracks or final failure.

Table 3.6: Impact Strength test for acid attack

Mix Proportion	Polymer Percentage	Average impact energy required to cause first crack (N-m)	Average impact energy required to cause final failure (N-m)
A	0	553.27	643.18
B	0.5	663.90	746.92
C	1.0	705.43	802.25
D	1.5	781.50	878.32
E	2	809.16	926.74
F	2.5	636.27	740.00
G	3	539.44	657.01

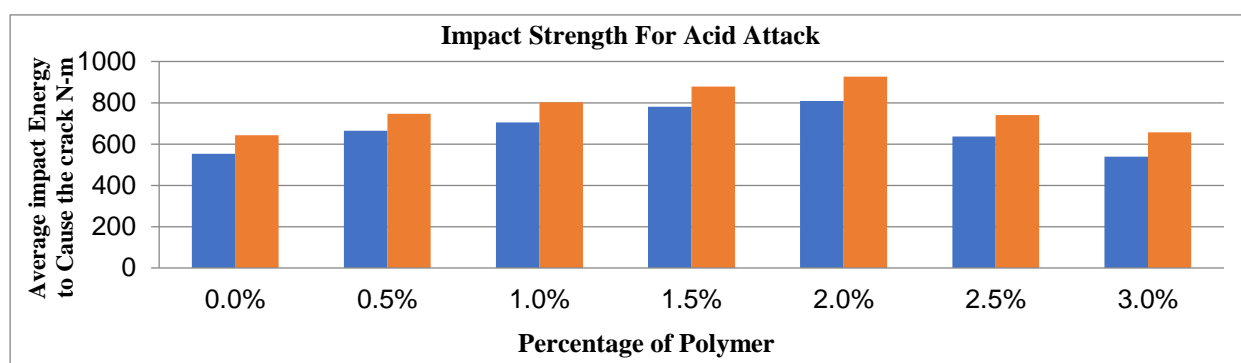

Fig. 3.6: BFRPC Impact Strength test for acid attack

4. Conclusion

Based on the durability tests result can be obtained from basalt fiber reinforced with addition of different percentage of polymer the following conclusions can be drawn.

1. The result obtained from workability tests increasing in polymer content decreases the workability.
2. From slump cone test it is noticed that addition of 1.5 % polymers will lead to collapsible concrete up to 3% of polymer.
3. Compressive strength of basalt fiber reinforced concrete with addition of 1.5% polymer mix is increased by 40Mpa under acid media for 180 days with regularly maintained pH 2.5.
4. Tensile strength of basalt fiber reinforced concrete with addition of 2% polymer mix is increased by 4Mpa under acid media for 180 days with regularly maintained pH 2.5.
5. Flexural strength of basalt fiber reinforced concrete with addition of 2% polymer mix is increased by 8.46Mpa under acid media for 180 days with regularly maintained pH 2.5.
6. Shear strength of basalt fiber reinforced concrete with addition of 2% polymer mix is increased by 20Mpa under acid media for 180 days with regularly maintained pH 2.5.
7. Impact strength of basalt fiber reinforced concrete with addition of 2% polymer mix first

crack is developed on 809.16 N-m and final failure crack is 926.74 N-m at 28 days. Impact strength has significance effect on basalt fiber reinforced concrete.

References

1. TUMADHIR M., BORHAN, Thermal and Mechanical Properties of Basalt Fibre Reinforced Concrete, World Academy of Science, Engineering and Technology, International Journal of Civil, Environmental, Structural, Construction and Architectural Engineering, 2013, Vol:7, No:4, pp. 334-337.
2. RAMA DEVI, R CHITHRA, B RAJESH,; Experimental study on strength properties of concrete with different aspect ratios of basalt fiber, International Journal of Civil Engineering and Technology (IJCIET), 2017, Vol. 8, Issue 9, pp. 629-637.
3. ABATHAR AL-HAMRANI, Shear behaviour of fibre reinforced concrete beam reinforced basalt bars, Sixth International Conference on Advances in Civil, Structural and Environmental Engineering - ACSEE 2017. DOI:10.15224/978-1-63248-139-9-29.
4. MAHZABIN AFROZ, INDUBHUSHAN PATHAIKANI, SRIKANTH VENKATESHAN, Chemical durability and performance of modified basalt fiber in

- concrete medium, *Construction and Building Materials*, 2017, pp.191-203. <https://doi.org/10.1016/j.conbuildmat.2017.07.153>
5. SATESHKUMAR, S. K., AWOYERA, P. O., KANDASAMY, T., NAGARAJ, S., MURUGESAN, P., PONNUSAMY, B. Impact resistance of high strength chopped basalt fibre-reinforced concrete. *Revista De La Construction. Journal of Construction*, 2018, 17(2), pp. 240–248. <https://doi.org/10.7764/RDLC.17.2.240>
 6. S K KIRTHIKA, S K SING, M SURYA,: Durability Studies on Basalt fiber reinforced concrete, *The Indian Concrete Journal*, 2018, Vol. 92, Issue 4, pp. 45-55.
 7. C SUDHA, Behaviour of fibre reinforced concrete using basalt fibre in beam column joint under cyclic loading, 2019, Vol 14, pp.1464 -1470.
 8. LAUER, K. R, Classification of concrete damage caused by chemical attack. RILEM recommendations 104-DDC: Damage classification of Concrete Structures. *Materials and Structures*, 1990, 23 (735), pp. 223 -229.
 9. R.M. SAWANT, SOHAIL SIDDIQUI,: Flexural and Shear Behaviour of Chopped Basalt Fiber Reinforced Concrete, *Journal of Structural Engineering, its Applications and Analysis*, 2020, Vol. 3, issue 1, pp. 1- 7.
 10. NASR Z. HASSAN, MAGDY GENIDI, RANIA M. ABDEEN, Shear Strength Behavior of Reinforced Concrete Beams with Basalt Fibers Added to the Mix, *Journal of Mechanical and Civil Engineering (IOSR-JMCE)*, 2021, Vol. 18, issue 2, pp. 21-29.
 11. RABEE SHAMASS, AZIZ URAHMAN HAKIMI, VIREEN LIMBACHIYA, Impact of chopped basalt fibres on the mechanical proper-ties of concrete, 3rd Conference on Sustainability in Civil Engineering (CSCE'21), 2021, pp.1-7.
 12. VARUN B K, ANILA KUMAR C P. Strength characteristics of polymer modified high volume fly ash concrete, *Materials Today Proceedings*, 46(4), 2021, 46, pp. 285-288. DOI:10.1016/j.matpr.2020.08.038
 13. VARUN B K, ANILA KUMAR C P.: Flexural and Shear characteristics of polymer modified high volume fly ash concrete, *Materials Today Proceedings*, 46(1), 2021, pp.289-293. DOI:10.1016/j.matpr.2020.08.040.
 14. BRAMESHUBER, W. UEBACHS, S.: Practical Experience with the Application of Self Compacting Concrete in Germany. *Proceedings of the International Symposium on Self Compacting Concrete*, Tokyo, Japan. 2016, pp. 687-695.
 15. MUHIT, I. B. RAIHAN, M. T. NURUZZAMAN, M.: Determination of Mortar Strength Using Stone Dust as a Partially Replaced Material for Cement and Sand. *Advances in Concrete Construction*, Vol. 2, Iss. 4, 2019, pp. 249–259.
 16. SUGITA, S. YU, Q. SHOYA, M. TSUKINAGA, Y. ISOJIMA, Y.: The Resistance of Rice Husk Ash Concrete to Carbonation, Acid attack and Chloride Ion Penetration. *Proceedings of the Third CANMET/ACI International Conference on High Performance Concrete: Design and Materials and Recent Advances in Concrete Technology*, ACI SP-172, V.M. Malhotra, ed., American Concrete Institute, Farmington Hills, Michigan, USA, 2017, pp. 29-43.
 17. OLUWASEUN MARK, ANTHONY EDE, CHINWUBA ARUM, PAUL AWOYERA, : Strength and Durability Assessments of induction Furnace Slag - Quarry Dust -Based High Performance Self – Compacting concrete, *Civil and Environmental Engineering*, Vol. 18, Issue 1, 1-16, DOI: 10.2478/cee-2022-0001
 18. KAZEEM K. ADEWOLE, ABAHO G. GERSHOME, MBEREYAHU LEOPOLD, : Finite Element Analysis Of Shear -Connection Shear - Out Fracture performance, *Civil and Environmental Engineering*, Vol. 18, Issue 1, 48-58, DOI: 10.2478/cee-2022-0005
 19. ABBAS ODA DAWOOD, AHMED MJBEL JABER, : Effect Of Dune Sand As Sand Replacement on The Mechanical Properties Of The hybrid Fiber Reinforced Concrete, *Civil and Environmental Engineering*, Vol. 18, Issue 1, 111-136, DOI: 10.2478/cee-2022-0012
 20. AMERICAN CONCRETE INSTITUTE (ACI 318-08) building code requirements for reinforced concrete.
 21. INDIAN STANDARD CODE (I.S: 5816-1999), splitting tensile strength of concrete - method of test, New Delhi.
 22. INDIAN STANDARD CODE (I.S: 516-1959), methods of tests for strength of concrete, New Delhi. [23] INDIAN STANDARD CODE (I.S10262-2016), concrete mix proportioning guidelines, New Delhi.
 23. INDIAN STANDARD CODE (I.S: 383-2016), specifications for fine and coarse aggregate from natural sources for concrete, New Delhi.