



A FIELD STUDY ON THE EFFECT OF BURRIED PVC PIPE LINES FOR IRRIGATION IN DEEVANUR TANK SYSTEM

Er.V.T.NEELMUDIYON

Research Scholar, Department of Civil Engineering,
HITS, Hindustan University, Padur, Chennai, India

Dr.V.PREETHI

Associate Professor, Department of Civil Engineering,
HITS, Hindustan University, Padur, Chennai, India

Dr.S.GOVINDARAJAN

Assistant Engineer, WRD, PWD, O/o. Irrigation Section, Uthiramerur, INDIA.

Article History:Received: 08.12.2022

Revised:18.1.2023

Accepted: 7.02.2023

Abstract:-

Water is a precious, natural resources for the mankind and all living species of the world. The first basic need of human life on this earth is food and water is the most vital input for food production. There is ever growing demand for water all over the world. The per capita availability of water in a country indicates the quality of life of the people. The water resources available in Tamilnadu State are poor with the per capita availability being just 0.023 Mcft against the National average of 0.078 Mcft. As the water becoming scarce day by day, the managements of the available water has assumed greater importance for sustainable growth. Out of all States in India, Tamilnadu is the second water scarce State in the country. The two monsoons bring only about 945mm of rain for the Tamilnadu on an average, one of the lowest in India. Since a large percentage of consumptive use is through irrigation, irrigation water management is to be given a high priority. Hence the necessity for water resources development and management becomes imperative. The research was conducted in Deevanur tank, which is situated in the Deevanur village of Tindivanam Taluk of Vilupuram District in Tamil Nadu, India. This study is conducted in Deevanur tank to find the impact of laying of buried PVC pipe lines in the sluice command area. From this study it is found that the crop cultivated area is 56% and cultivation of paddy crop in second season is also enabled.

Keywords—Tank Irrigation, Field channel, Evapo-transpiration, Blue water, Green water, CRIWAR and Water Balance.

DOI: 10.31838/ecb/2023.12.2.011

1. INTRODUCTION

Water is a precious, natural resources for the mankind and all living species of the world. The first basic need of human life on this earth is food and water is the most vital input for food production. There is ever growing demand for water all over the world. The per capita availability of water in a country indicates the quality of life of the people. The National Water Policy adopted by India in September 1987 has made it abundantly clear that water is a scarce and precious national resource to be planned, developed and conserved as such and on an integrated and environmentally sound basis, keeping in view the needs of the States concerned.

Article 3 suggests conservation of the available resources and maximising the availability and minimising the losses. Stressing that the scientific outlook should be brought to bear on the effective and economical management of water resources it is stated in Article 19 of the National Water Policy that “frontiers of knowledge need to be pushed forward in several directions by intensifying research efforts in various areas including evaporation and seepage losses, better water management practices and improvements in operational technology and so on”.

India has 17% of the world’s population, 18% of cattle population but only 4% of the world’s renewable water resources and 2.44% of geographical area. As per report of National Commission on Integrated Water Resources Development (NCIWRD), the total water availability of India received through precipitation is about 4000 billion cubic meter (BCM) per annum. After evaporation, 1869 BCM water is available as natural run off. Due to the consideration of topographical, geographical and other factors, the available of water for the usage for the daily activities is restricted to 1122 BCM, which also includes 690 BCM of surface water and 432 BCM of ground water. As per NCIWRD (1999), the total water demand of the country has been estimated as 710 BCM, 843 BCM and 1180 BCM for the years 2010, 2025 and 2050 respectively as shown in figure 1. Availability of water is highly uneven in both space and time, with monsoon confined only to four months in a year . (Department of water resources, RD and GR, Ministry of Jal Shakthi).

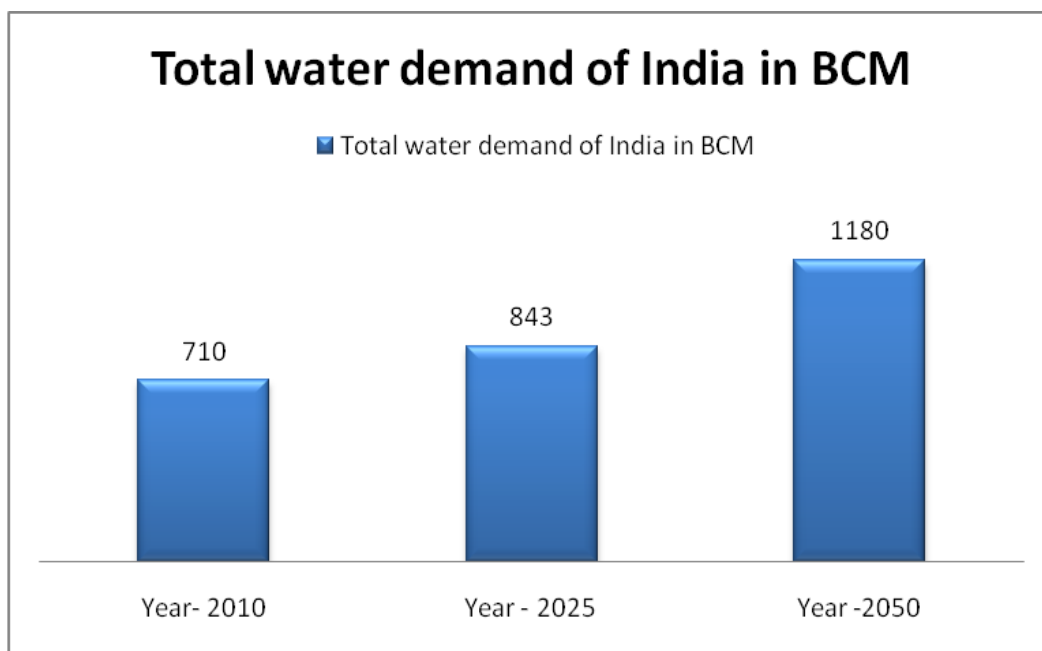

Figure No.1 Projection of India water demand

The water resources available in Tamilnadu State are poor with the per capita availability being just 0.023 Mcft against the National average of 0.078 Mcft. As the water becoming scarce day by day, the managements of the available water has assumed greater importance for sustainable growth. Out of all States in India, Tamilnadu is the second water scarce State in the country. The two monsoons bring only about 945mm of rain for the Tamilnadu on an average, one of the lowest in India. Tamilnadu State at the Southern tip of the Indian subcontinent has the geographical disadvantage of lying to the leeward side of the Western Ghats thus missing the benefits of the main monsoon for the country namely the South West monsoon which is more

dependable. Though the receding monsoon named as the North East monsoon serves this state it is less predictable with a high coefficient of variation and also sets in association with depressions in the Bay of Bengal. Since a large percentage of consumptive use is through irrigation, irrigation water management is to be given a high priority. Hence the necessity for water resources development and management becomes imperative. (Mohana Krishnan.A, 2004)

Tamil Nadu is the second biggest area of about 0.595 Million hectares under the cultivation of tank irrigation. This is nearly $\frac{1}{4}$ of the tank irrigated area in India. The tank irrigation is predominantly used in Tamilnadu due to the existing rocks underneath the grounds. This makes difficulties in establishing dig canals and wells.

This study is proposed to conduct the impact of modernisation on the tank irrigation system. For that Deevanur tank was chosen to study which is situated in the Deevanur village in of Tindivanam Taluk of Vilupuram District located at Tamil Nadu, India. This tank was modernised by providing buried PVC pipe lines for irrigation instead of field channels which are off taking from the tank sluices. Since the project was commissioned on 2012-13, to find the effect of the project, a study was conducted for a pre implementation period of 2010-11 & 2011-12 and for a post implementation period of 2012-13 & 2013-14.

STUDY AREA

The study was conducted at Deevanur tank, which is situated in Deevanur village in a part of Tindivanam Taluk of Vilupuram District located in Tamil Nadu, India. This tank is been situated across the northern side of Tindivanam towards Gingee State Highways in the Mailam Block, which is found at 11km from Tindivanam. It geographical location of the area is about Latitude 12°15'00" North and Longitude 79°25'00" East.

Deevanur Tank falls under the category of "Non-System tank" and it receives the natural water from free catchment area of size 2.613 km² and the combined catchment area of size about 6.813 km². The annual storing capability of the tank was estimated to be 0.432 Mm³. The tank serves as the primary source for irrigation for the area of about 72.19 hectare through two different sluices. On to the right part of the flank two weirs is been located through which the surplus amount of water is discharged in to the Thondiyar River. The water spread area of the respective tank was found to be 0.285 km². This tank is constructed over an earthen bund of length about 1250m.

This tank irrigates the command area through the two numbers of sluices. Sluice no.1 located in the left flank which is the deepest one and irrigates about an area of 60.60 hectares the remaining area irrigated by sluice no.2 which is 11.59 hectares. The ayacut areas benefited under sluice 1 and 2 are shown in figure 2.

Deevanur Tank falls under Varaghanadhi sub caterogy Basin of Varaghanadhi River Basin. To accomplish the objective of "more money per drop of water" i.e., efficient and optimum utilization of the scarce resource water, the traditional open channel irrigation was replaced by the buried PVC pipe lines for gravitational conveyance of irrigation water. This tank irrigates the command area through open field channels up to 2011-12. After implementation of the world bank scheme in 2012-13, the underground P.V.C. pipe lines are laid to irrigated the command

area, which reduces conveyance, evaporation and loses due to infiltration. This tank intakes the excess water from the Agoor Tank.

During the implementation of the project, sluice No. 1 the ayacut is divided into the three main blocks and each main block is further divided into three sub blocks area to facilitate rotational irrigation method. In Sluice No. 2, the ayacut is considered as a single block and divided into three sub blocks area to facilitate rotational irrigation method. The schematic network of buried PVC pipe lines system is shown in figure 3. Figure 4 represents the schematic diagram of division box.

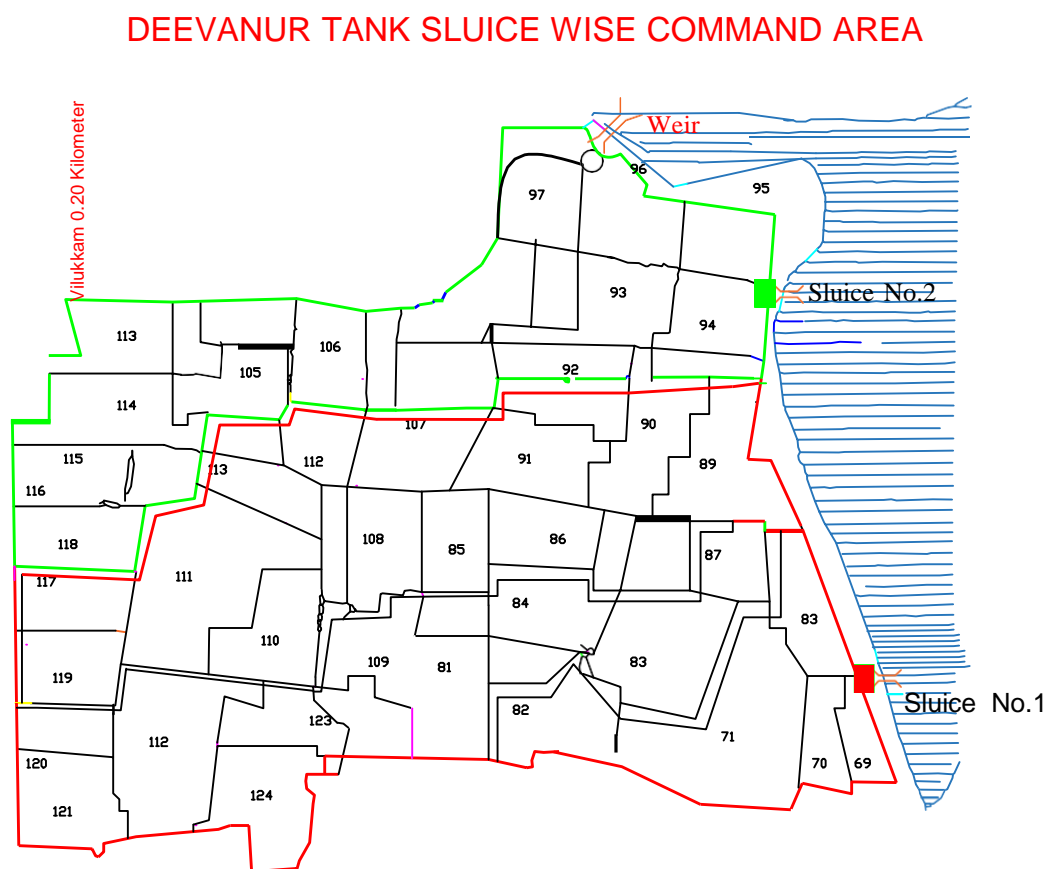

Figure No.2 – Deevanur tank command area

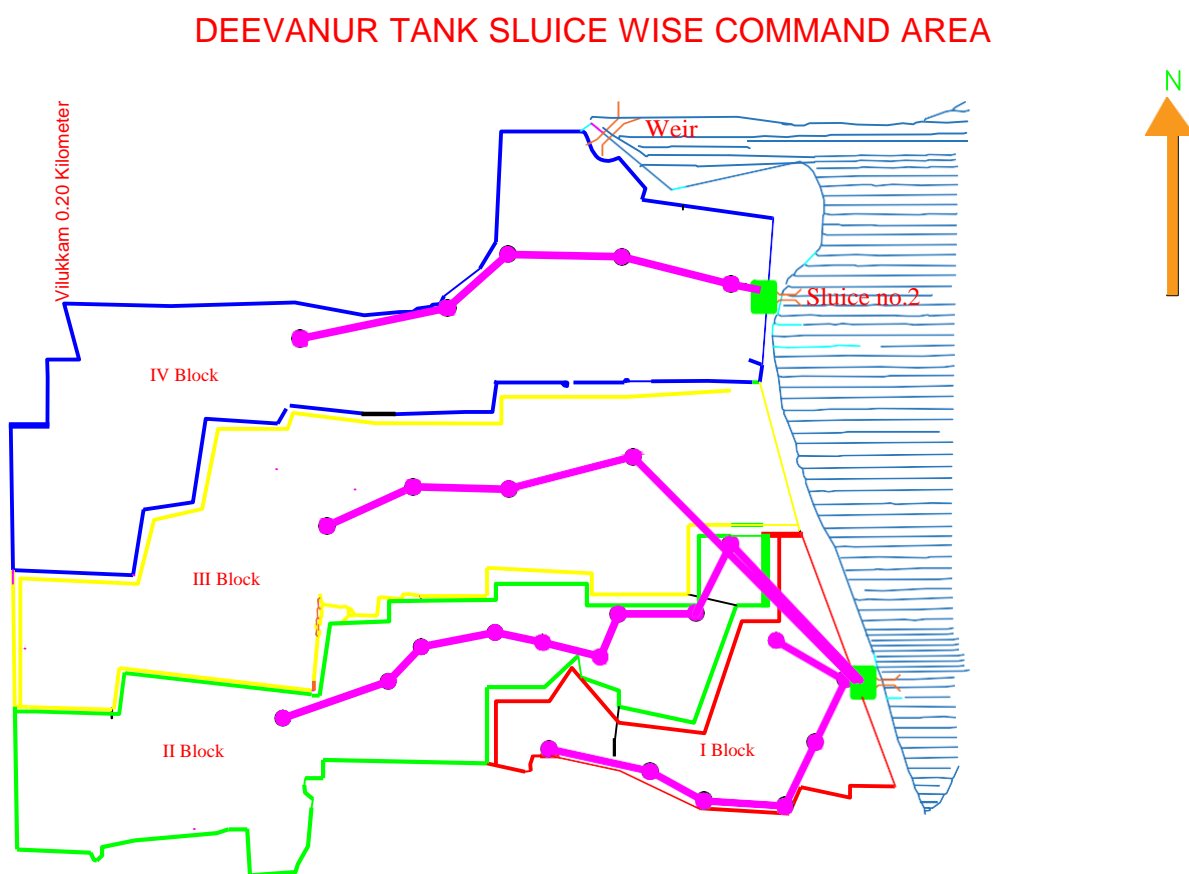





Figure No.3 – Deevanur tank command area

	I Block	21.865 Ha	Sluice No.1
	II Block	23.860 Ha	

	III Block	14.875 Ha	
	IV Block	11.590 Ha	Sluice No.2

Sluice no.1

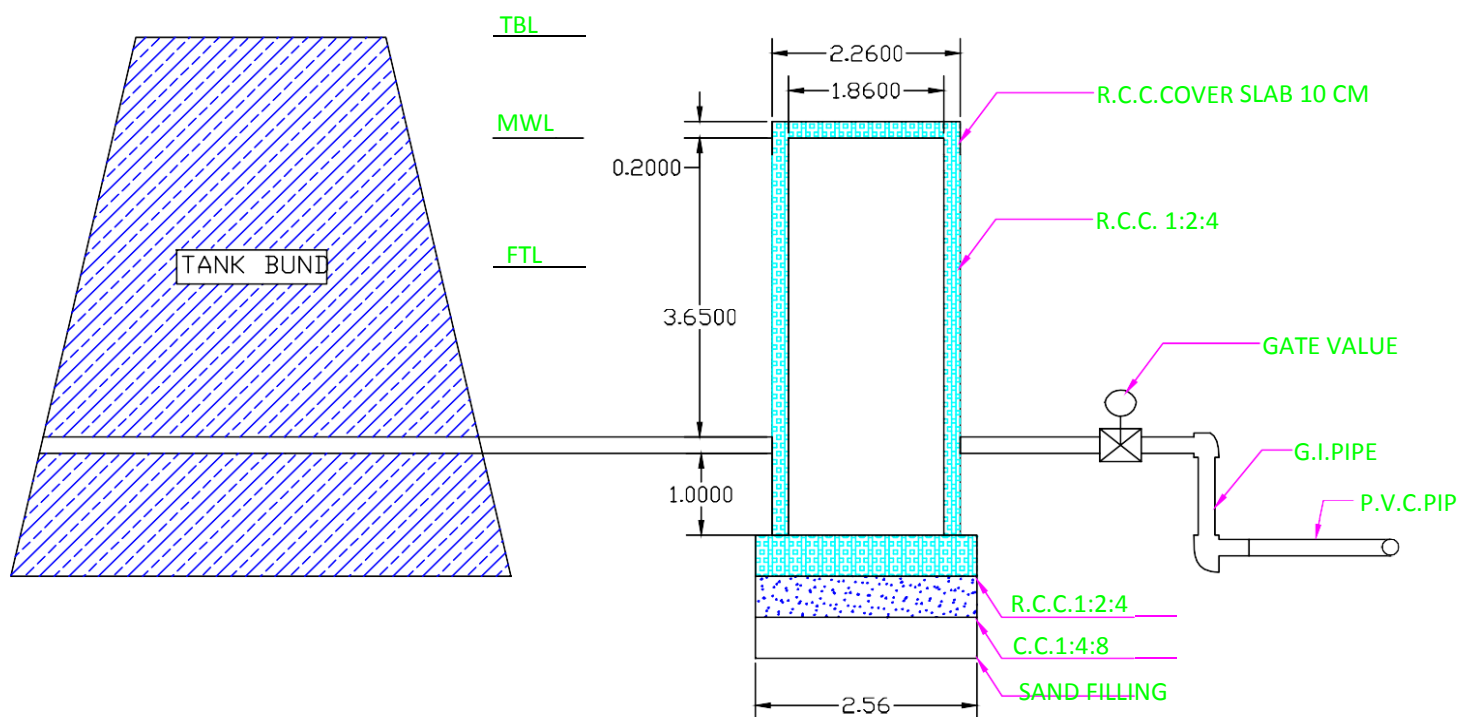

FIGURE NO. 4 SCHEMATIC DIAGRAM OF DIVISION BOX

A. CLIMATE

For this research the meteorological data were collected from Kiledayalam climatic station which is governed by the "State Ground and Surface Water Resources Data Centre" a state government authorised body (SG&SWRDC), PWD over the years of 2010, 2011, 2012, 2013 and 2014. The data were collected as daily ambient temperature, relative humidity, sunshine hours, wind intensity, average rainfall and pan evaporation.

During the study period of time over the years 2010-11, 2011-12, 2012-13 and 2013-14 the average temperatures recorded were 29.16, 27.01, 28.50 and 27.85°C, average relative humidity's were 79, 75, 77 and 75%, average sunshine hours were 6.67, 6.56, 7.14 and 7.15hrs and average wind velocities were 13.84, 12.98, 13.25 and 12.12 km/hour respectively.

B. Rainfall

Rainfall during the study period (June 2010- May 2011, June 2011- May 2012, June 2012- May 2013 and June 2013 - May 2014) were 1200.80, 1212.50, 1072.80 and 1059.40mm. In which around 55% of annual rainfall received on north - east monsoon (October to December), 31.45% of rainfall was recorded towards south west monsoon (June to September) and summer rainfall

was recorded and it is found to be 13.5% (March to May). Usually this area is predominantly influenced by the North-East monsoon during the months of October to December.

C. Cropping pattern

The crop calendar year in Deevanur tank command area starts from June to May over the period of years 2010-11, 2011-12, 2012-13, 2013-14 and the crops cultivated were showcased table 1.

The first season normally paddy is been cultivated from September to December, For The second season paddy cultivation practiced here is known as Navarai which starts from January to April, and the annual sugarcane crop cultivation begins from July to April.

Table 1: Details of crop cultivation during 2010-11, 2011-12, 2012-13 and 2013-14.

Sl.No	Year	Sluices	Reaches	Crop cultivated area in Ha.			
				Paddy-I	Paddy-II	Sugarcane	Fallow
		Season		Samba	Navarai	Annual	
Period		September to December	January to April	July to April	-		
1	2010-11	Sluice-1	Head	9.71	-	8.91	2.28
			Middle	9.63	-	8.89	2.33
			Tail	8.64	-	8.04	2.17
		Sluice-2	Head	1.82	-	1.68	0.44
			Middle	1.80	-	1.66	0.44
			Tail	1.73	-	1.59	0.42
2	2011-12	Sluice-1	Head	7.66	-	10.95	2.29
			Middle	7.59	-	10.93	2.33
			Tail	6.82	-	9.88	2.18
		Sluice-2	Head	1.43	-	2.07	0.45
			Middle	1.42	-	2.04	0.44
			Tail	1.36	-	1.96	0.41
3	2012-13	Sluice-1	Head	6.89	6.89	14.01	-
			Middle	6.87	6.87	13.98	-
			Tail	2.84	2.27	12.64	3.37

		Sluice-2	Head	1.30	1.30	2.65	-
			Middle	1.29	1.29	2.61	-
			Tail	0.58	0.48	2.51	0.64
4	2013-14	Sluice-1	Head	6.35	6.35	14.55	-
			Middle	6.34	6.34	14.51	-
			Tail	2.91	2.30	13.12	2.82
		Sluice-2	Head	1.20	1.20	2.75	-
			Middle	1.18	1.18	2.72	-
			Tail	0.61	0.49	2.60	0.53

MODEL

The Model which is been used to determine the water balance component in the command area is "CRIWAR 3.0". This model was established by Bos M.G (1988), Bos M.G et al., (1996) and Bos M.G et al., (2008), the method of analysis using this model is already discussed in Neelmudiyon V T *et al* (2020).

IV.RESULT

Pre Project period 2010-12 for samba season:-

In Samba season, paddy crops cultivated area were 33.33ha and 26.28ha for the years 2010-2011 and 2011-12 respectively. Consumptive use of paddy crop i.e quantity of actual evapotranspiration are 118084 m³ and 88687 m³ during the years 2010-11 and 2011-12 respectively, the variation among the sluices and reaches are shown in figure 5. Effective rainfall during these seasons in 2010-11 and 2011-12 are 40237 m³ and 25494m³ respectively, the variation among the sluices and reaches are shown in figure 6. The consumptive use of crop for the years 2010-11 and 2011-12 met from irrigation were 77847 m³ and 68650 m³ respectively, the variation among the sluices and reaches are shown in figure 7.

Post Project period 2012-14 for samba season:-

In Samba season, paddy crops cultivated area were 19.77ha and 18.59ha for the years 2012-2013 and 2013-14 respectively. Consumptive use of paddy crop i.e quantity of actual evapotranspiration are 93827 m³ and 88485m³ during 2012-13 and 2013-14 respectively, the variation among the sluices and reaches are shown in figure 5. Effective rainfall during these

seasons in 2012-13 and 2013-14 are 20468 m³ and 19660 m³ respectively, the variation among the sluices and reaches are shown in figure 6. The consumptive use of crop in 2012-13 and 2013-14 met from irrigation were 72995 m³ and 68825 m³ respectively, the variation among the sluices and reaches are shown in figure 7.

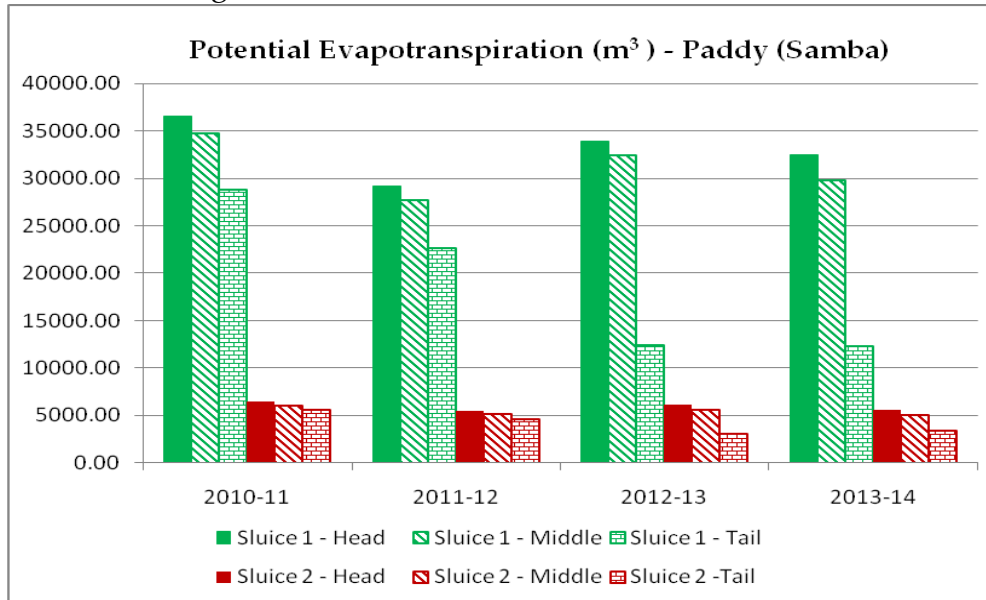

Figure No. 5, Sluice & Reach wise evapotranspiration of Paddy - Samba

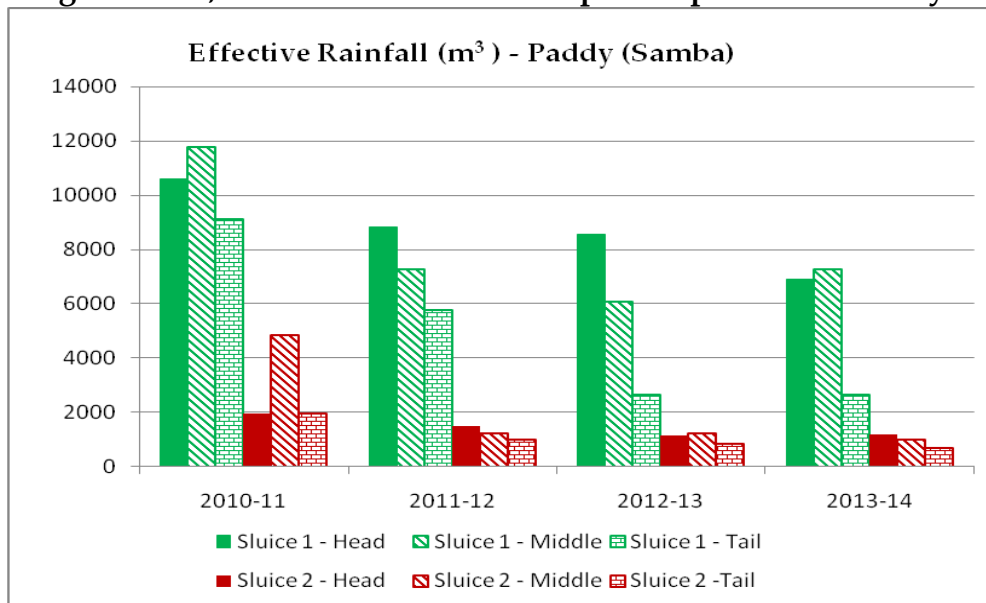

Figure No.6, Sluice & Reach wise Effective rainfall of Paddy - Samba

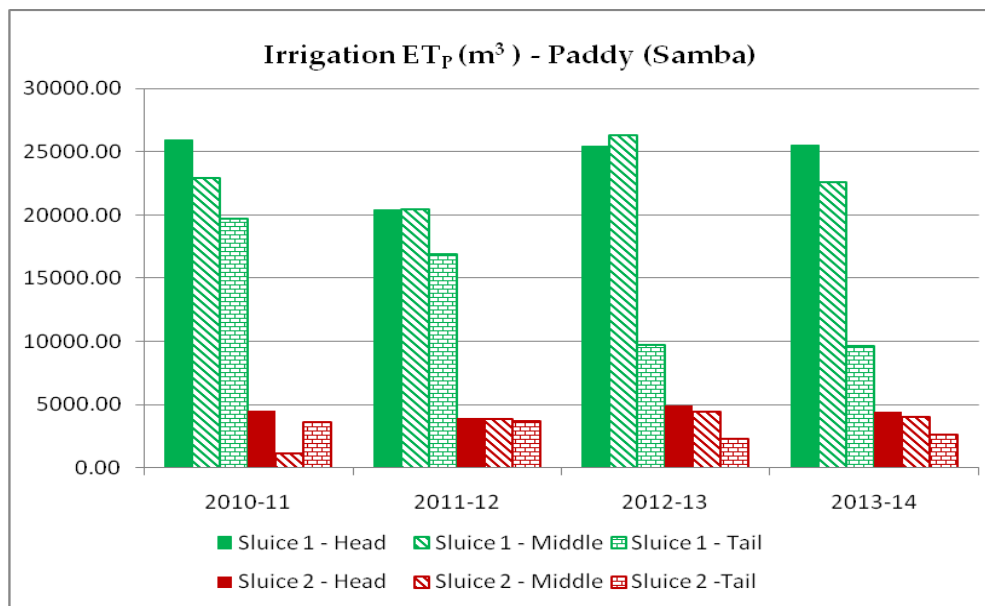

Figure No.7, Sluice & Reach wise Irrigation of Paddy – Samba

Pre Project period 2010-12 for Navarai season:-

In Navarai season, no paddy crops are cultivated for the years 2010-11 and 2011-12 in Deevanur tank command area.

Post Project period 2012-14 for Navarai season:-

In Navarai season, paddy crops cultivated area were 19.10ha and 17.86ha for the years 2012-2013 and 2013-14 respectively. Consumptive use of paddy crop i.e quantity of actual evapotranspiration are 103287 m³ and 76258 m³ during the years 2012-13 and 2013-14 respectively, the variation among the sluices and reaches are shown in figure 8. Effective rainfall during these seasons in 2012-13 and 2013-14 are nil. The consumptive use of crop in 2012-13 and 2013-14 is 100% met from irrigation. Hence the ET_p of paddy crop is equal to the irrigation ET_p of paddy crop. i.e. 103287 m³ and 76258 m³ respectively in 2012-13 and 2013-14.

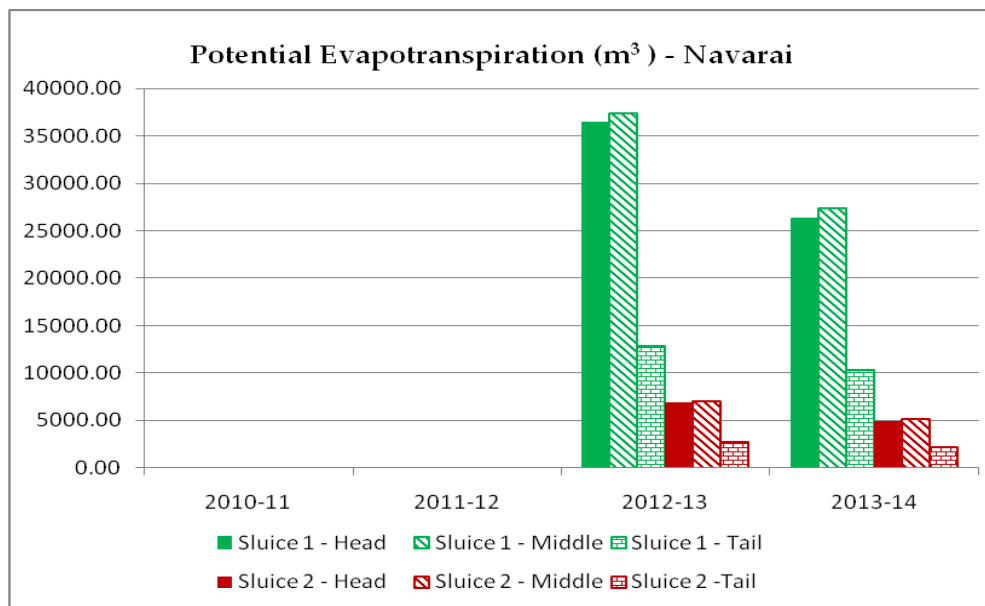

Figure No.8, Sluice & Reach wise evapotranspiration of Paddy - Navarai

Pre Project period 2010-12 for Sugarcane crop:-

The Sugarcane crop cultivated area were 30.77ha and 37.81ha for the years 2010-2011 and 2011-12 respectively. Consumptive use of sugarcane crop i.e quantity of actual evapotranspiration are 4220387 m³ and 564802 m³ during the years 2010-11 and 2011-12 respectively, the pattern of variations among sluices and reaches are shown in figure 9. Effective rainfall during these seasons in 2010-11 and 2011-12 are 64980 m³ and 70393 m³ respectively, the variation among the sluices and reaches are shown in figure 10. The consumptive use of crop 2010-11 and 2011-12 met from irrigation were 355406 m³ and 494409 m³ respectively, the variation among the sluices and reaches are shown in figure 11.

Post Project period 2012-14 for Sugarcane crop:-

The Sugarcane crop cultivated area were 48.40ha and 50.25ha for the years 2012-2013 and 2013-14 respectively. Consumptive use of sugarcane crop i.e quantity of actual evapotranspiration are 678250 m³ and 765375 m³ during the years 2012-13 and 2013-14 respectively, the variation among the sluices and reaches are shown in figure 9. Effective rainfall during these seasons in 2012-13 and 2013-14 are 75575 m³ and 103370 m³ respectively, the variation among the sluices and reaches are shown in figure 10. The consumptive use of crop 2012-13 and 2013-14 met from irrigation were 758052 m³ and 662007m³ respectively, the variation among the sluices and reaches are shown in figure 11.

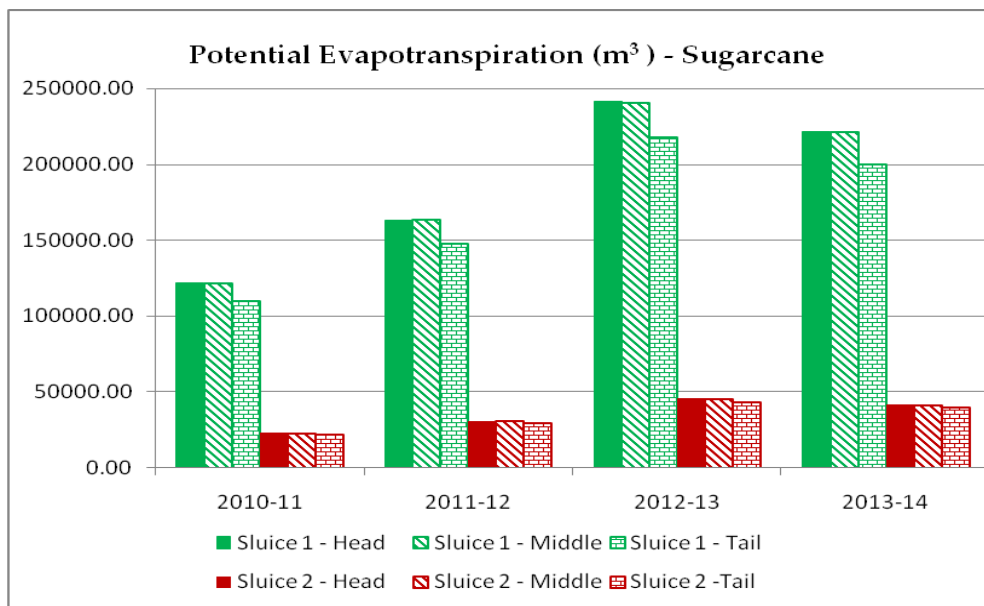

Figure No.9, Sluice & Reach wise evapotranspiration of Sugarcane

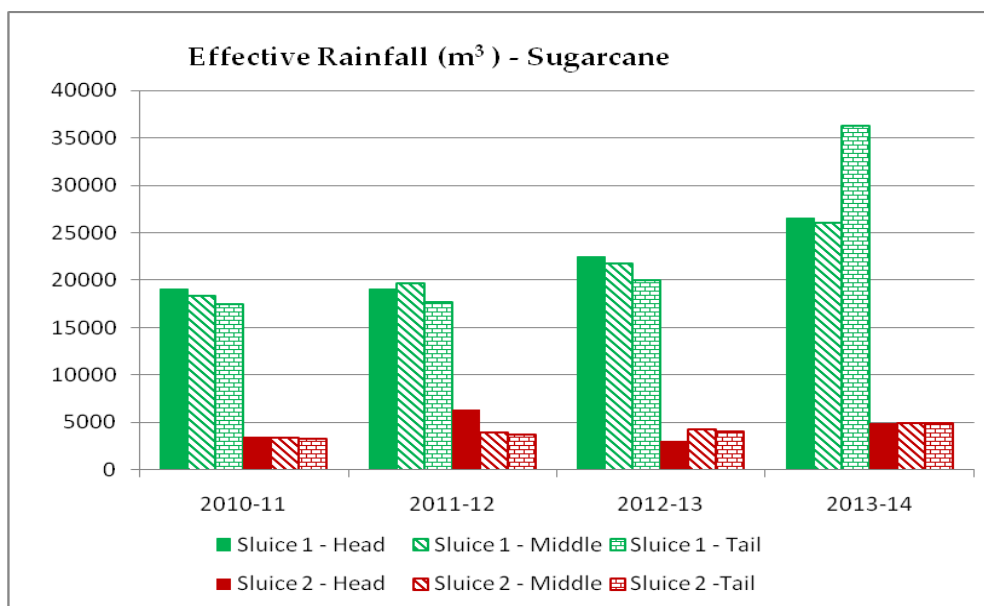

Figure No.10, Sluice & Reach wise effective rainfall of Sugarcane

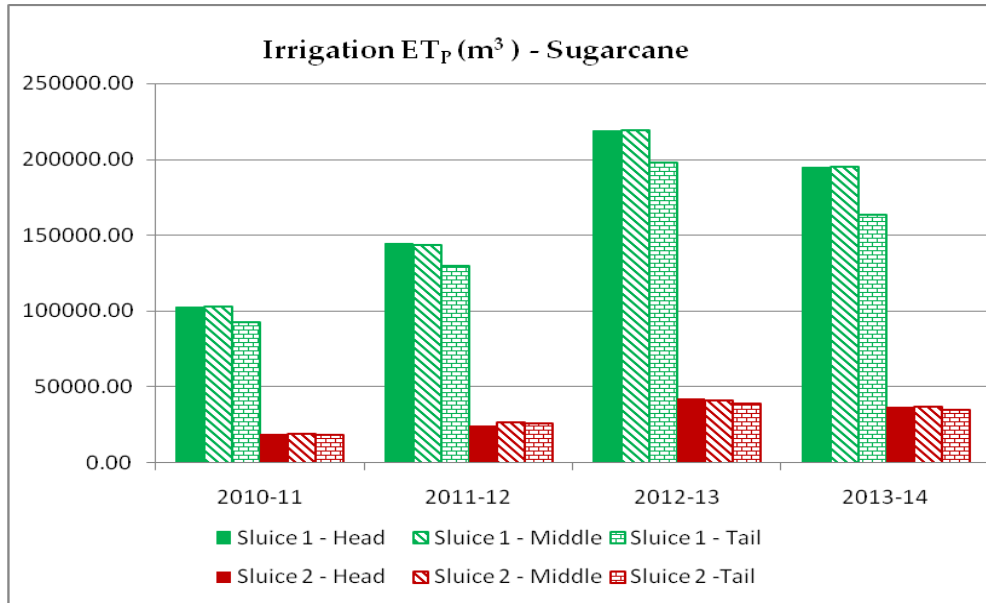

Figure No.11, Sluice & Reach wise Irrigation of Sugarcane

C. Fallow land

During the pre project period 2010-11 and 2011-12, fallow lands are 8.09 ha and 8.10 ha respectively. Under the post project period 2012-13 and 2013-14 fallow lands are 4.02 ha and 3.35 ha respectively. In the pre project period, the quantity of water lost to atmosphere from the fallow lands are 27782 m³ in 2010-11 and 34650 m³ in 2011-12. For the post project period 2012-13 and 2013-14 is 25020 m³ and 15249 m³ respectively. The sluice and reach wise water loss from fallow fields as evapotranspiration are shown in figure 12.

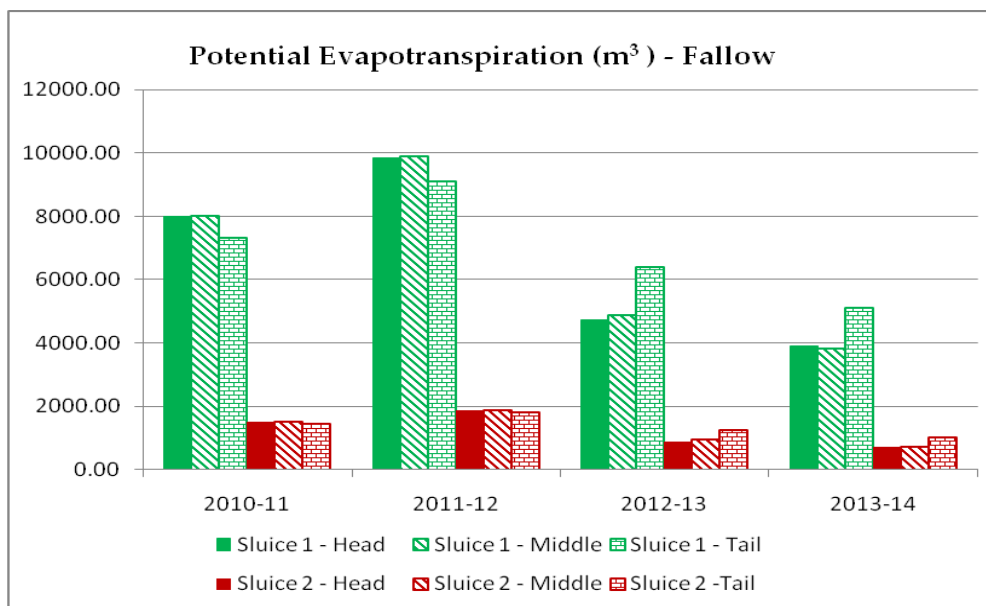

Figure No.12, Sluice & Reach wise evapotranspiration of fallow land

V. Discussion

Paddy:-

In Samba season, the paddy cultivated area in pre project years 2010-11 and 2011-12 are 46.17% and 36.40% respectively at the tank level. But in the case of post project years 2012-13 and 2013-14, the paddy cultivated area are 27.39% and 25.79% respectively. The variation of the paddy cultivated area in year wise, sluice wise and reach wise are shown in figure 13.

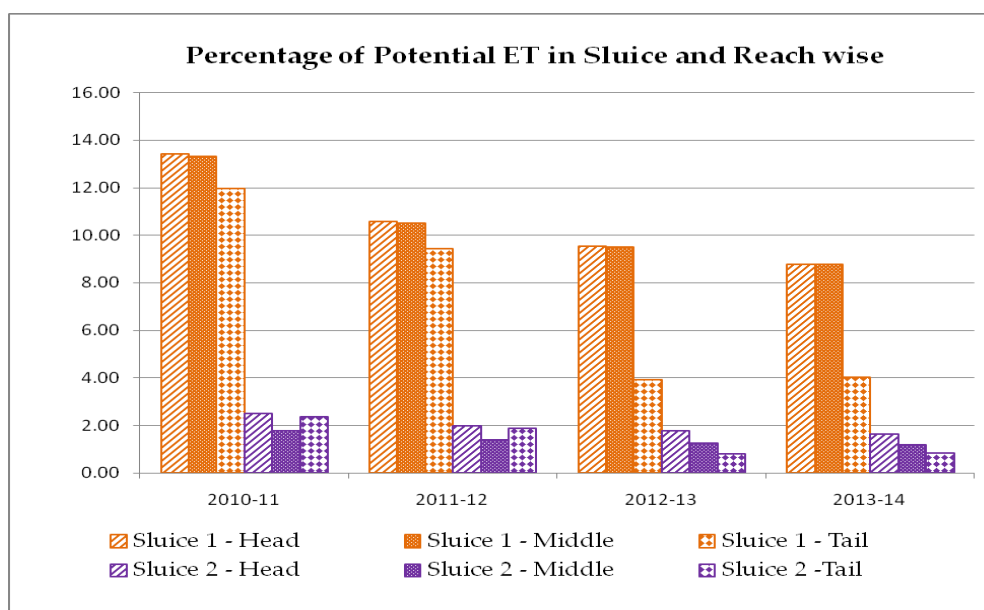

Figure No.13, Percentage of crop cultivated area in year, sluice and reach wise for Samba crop

In Navarai season, at the level of tank, the paddy cultivated area in pre project years 2010-11 and 2011-12 no cultivation was practised. But in the case of post project years 2012-13 and 2013-14, the crop cultivated area are 26.46 and 24.74% respectively. The variation of the paddy cultivated area in year wise sluice wise and reach wise are shown in figure 14.

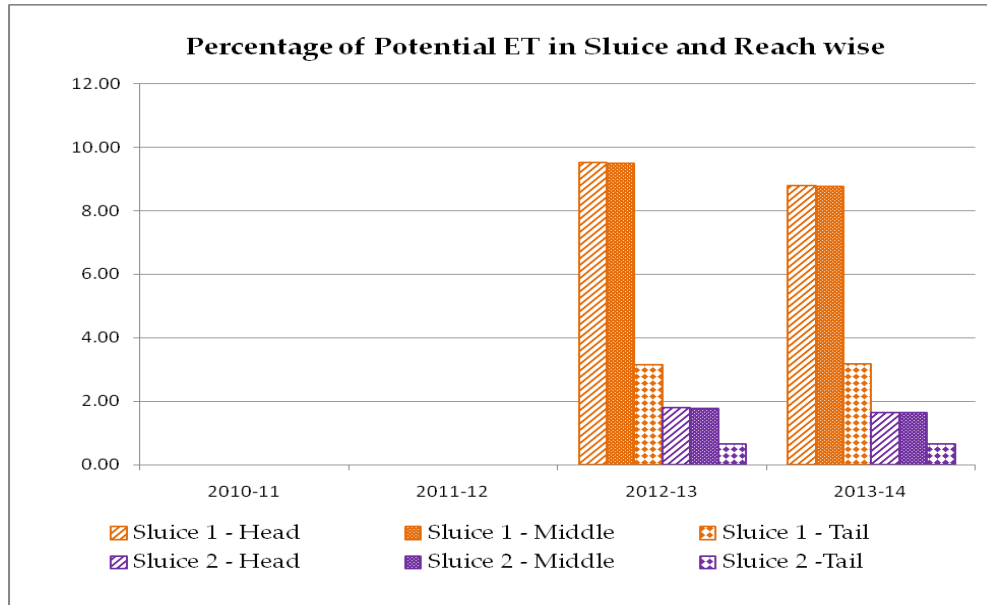

Figure No.14, Percentage of crop cultivated area in year, sluice and reach wise for Navarai crop

Sugarcane

The sugarcane cultivated area, at the level of tank, in pre project years 2010-11 and 2011-12 are 42.63% and 52.38% respectively. But in the case of post project years 2012-13 and 2013-14 are increased significantly to 67.05% and 69.61% respectively. The variation of the sugarcane cultivated area in year wise , sluice wise and reach wise are shown in figure 15.

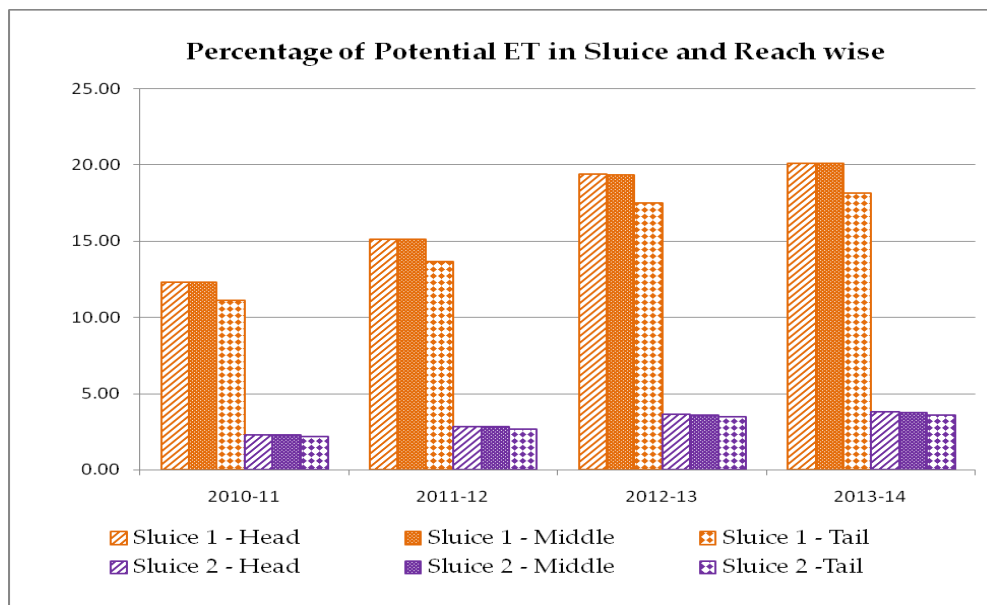

Figure No.15, Percentage of crop cultivated area in year, sluice and reach wise for Sugarcane crop

Fallow Land

The uncultivated area or fallow land at the level of tank, in the pre project years 2010-11 and 2011-12 are 11.21% and 11.22% respectively. But in the case of post project years 2012-13 and 2013-14, the fallow land are decreased to 5.55% and 4.63% respectively. The variation of the potential ET from uncultivated area in year wise, sluice wise and reach wise are shown in figure 16.

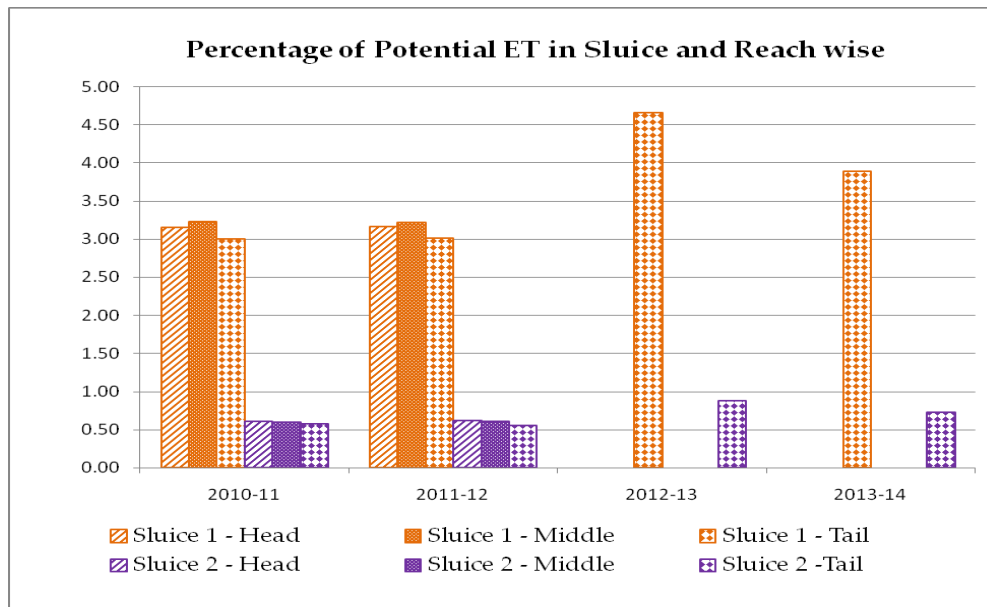

Figure No.16, Percentage of crop cultivated area in year, sluice and reach wise for uncultivated area

The overall performance of the tank system after implementation of the project with respect to the evapotranspiration in the command area of the tank is shown in figure 17. This figure reveals that after implementation of the project, the evapotranspiration in the sugarcane fields are 80%, the paddy fields are 16% and the remaining 4% accounted from the fallow fields.

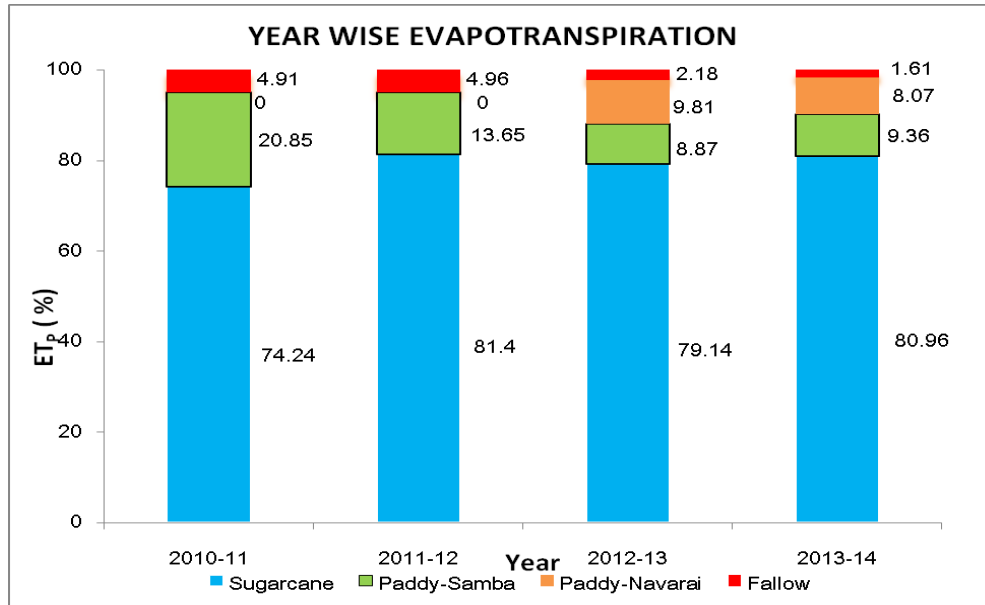

Figure No.17, Percentage of crop cultivated area in year wise for uncultivated area

V. Conclusion

This study found that, after the implementation of PVC buried pipe lines for irrigation through sluices, leads to decrease in the crop cultivated area for paddy about 14.70%, but in the case of Sugarcane growing area increased to 21%. The uncultivated area is 6% decreased. Hence after implementation of the project, sugarcane cultivation area is increased significantly. This study also reveals that, after the implementation of PVC buried pipe lines for irrigation through sluices leads to increase in the crop cultivated area. The crop cultivated area in the pre project years 2010-11 and 2011-12 are 72.18ha and 72.21ha respectively. Whereas after implementation of the project for the years 2012-13 and 2013-14 the crop cultivated area are 91.28ha and 90.05ha respectively. It shows that 26% of area of cultivation is increased because of double crop cultivation.

In the pre project years 2010-11 and 2011-12, the total ET_P from the command area were 566253 m^3 and 693865 m^3 respectively. After modernisation of the system, the total potential evapotranspiration for the command area for the years 2012-13 and 2013-14 were 1053361 m^3 and 945368 m^3 respectively. Because of the implementation of the modernisation, the crop water usage i.e. the potential evapotranspiration in the command area is increased 58% significantly. According to Donaldson.M (2013) improving agricultural output to increase food production and increase living standards of the farmers, modernisation of irrigation system is necessary. This study also revealed that, after modernisation of the tank system, the cultivated area and usage of water for crops are increased significantly in the Deevanur tank also there by directly improves the living standards of the farmers.

REFERENCE

- 1) Bos,M.G. (1988), Crop irrigation water requirements, ILRI, Wageningen

- 2) Bos,M.G., Vos,J. and Feddes, R.A. (1996). CRIWAR 2.0: A Simulation Model on Crop Irrigation Water Requirements. ILRI, Wageningen
- 3) Bos, M.G., Kselik, R.A.L., Allen, R.G. and Molden, D.J. (2008). Water requirements for Irrigation and the Environment. Springer publication, Dordrecht. 174p
- 4) Department of water resources, RD and GR, Ministry of Jal Shakthi, Concept note on national water conservation scheme (Jal Jeevan Mission – Varsha Jal dhara Ke Tal),H.11014/1/2014-GW Desk (Part IX).
- 5) Donaldson.M (2013) Rehabilitation and modernisation of irrigation schemes., water management 166(5):242-253
- 6) Mohanakrishnan. (2004). Water Resources Development & Management. Publication No.43. Irrigation Management Training Institute: Trichy, Tamilnadu.
- 7) Neelmudiyon,V.T., Preethi,V and Govindarajan,S. (2020). A study on conjunctive use of green and blue water in Deevanut tank irrigated area, *International Journal of Advanced Research in Engineering and Technology (IJARET) Volume 11, Issue 9,September 2020,pp.272-281.*