



MODELING AND SIMULATION OF A HYBRID PV, WIND & BATTERY STORAGE OFF-GRID POWER SYSTEM

^[1] Gaurav Mishra*, ^[2] Satyam Kumar Upadhyay, ^[3] Dr. Rajnish Bhasker

^[1] M.Tech Research Scholar, Department of Electrical Engineering, Faculty of Engineering and Technology, Veer Bahadur Singh Purvanchal University, Jaunpur ^[2] Assistant Professor, Department of Electrical Engineering, Faculty of Engineering and Technology, Veer Bahadur Singh Purvanchal University, Jaunpur ^[3] Professor & Head, Department of Electrical Engineering, Faculty of Engineering and Technology, Veer Bahadur Singh Purvanchal University, Jaunpur

^[1] gauravmishraee037@gmail.com, ^[2] satyam@vbspu.ac.in, ^[3] rbhasker@vbspu.ac.in

^[1] ORCID ID: <https://orcid.org/0009-0003-4978-7692>

^[2] ORCID ID: <https://orcid.org/0000-0003-3123-9279>

Abstract— Though with today's technology, numerous distant regions throughout the globe are not linked toward the electric system. Hybrid renewable energy storage are ideal for supplying power to remote and rural locations. The modelling, assessment, & computation of a composite power system are the emphasis of this research. The solar and wind power stations serve as major electricity generation, while the charger serves as a secondary energy source. Because when mixed system capacity is lesser than the duty cycle, the influence generation technique is required to preserve surplus influence after mixture PV/wind equipment then toward provide continual energy to the scheme. To administer and maintain the energy infrastructure, a bilingual DC-DC converting governed by a controller with fuzzy logic controller (FLC) is employed. (MPPT) was used as a control approach to collect the peak power from either the wind and PV power sources. To decrease wastage in the hybrid version, DC-DC converters are employed in conjunction with a Control scheme. Considering shifting climatic circumstances, solar PV and windfarm future governance are explored. To model, simulate, and analyses the complete mixed powertrain, MATLAB/Simulink programming is employed.

Index Terms— PV, Wind, Battery Storage, VSC, ANFIS, Fuzzy MPPT, Permanent Magnet Synchronous Generator.

I. INTRODUCTION

Power is critical to the advancement of countries, and it's the fundamental component accountable about any government's industrial and social prosperity. As a result, it must be conserved extremely effectively. Developing energy assets in the most cost-effective manner should then be provided sufficient priority. Furthermore, technology for producing energy in an environmentally beneficial way should have been improved [1]. Because since commencement of the industrialization, energy production has become the main source of energy [2]. Carbon emissions are non-renewable commodities since they require millions of years to regenerate. Renewable energies are materials that are readily accessible in ecology, including wind farms, or that container remain replenished in a short amount of period, including such traditional biomass.

Many businesses and governments are showing success of deep in research on renewable energies & programs these times, owing to concerns about just the finite supply of fossil fuels and ecological damage. This has prompted researchers to explore green and renewable energy supplies in order to safeguard the climate and minimize dependency on fossil fuels [3]-[5]. A integration of renewable method incorporates renewable and alternative energy components into a centralized platform with a monitoring mechanism that allows the component to provide electricity of the required quality [6]. Solar and wind energy sources exhibit unpredictability and randomness. Wind panels is inconsistent since the amounts of solar radiation are altered by current environmental such as temperature and clouds [7]. Because winds has tremendous strength, it is highly unpredictable in nature. As a result,

electricity generated is sometimes seen as untrustworthy. Devices that store electricity may help to increase the durability and dependability of renewable sources of power. As a result, a mixture energy organization that combines solar PV, a power station, and a power storage process is generally higher dependable than either solar and wind power PV alone [8]-[11]. A mixed solar PV/wind power source with an energy storage system is developed, researched, and evaluated in this study.

II. MODELING AND SIMULATION

A. The Photovoltaic Systems Simulation

A photovoltaic cell converts amount of solar radiation into electricity, a DC-DC dc source, and the maximum power point of a PV system includes a (MPPT) management mechanism (MPP). The planned PV program's block diagram is provided in Fig 1.

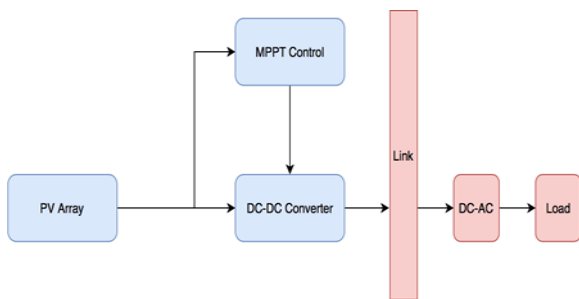

Fig 1: The proposed PV system.

To illustrate the examination of perfect PV cells in electrical wiring [12], the electrical system of an optimal Photovoltaic panel is provided in Fig 2. A charge controller based on radiation and temperatures in tandem with such an overturned electrical component may be used to represent this connection. The perfect PV cell may be theoretically described using the following equation [12]:

$$I = I_{ph} - I_0 e^{\frac{q(V+R_S I_{pv})}{nKT}} - \frac{V + I_{pv} \times R_S}{R_p} \quad (1)$$

Fig 2: The electrical circuit of a single-diode PV cell [12].

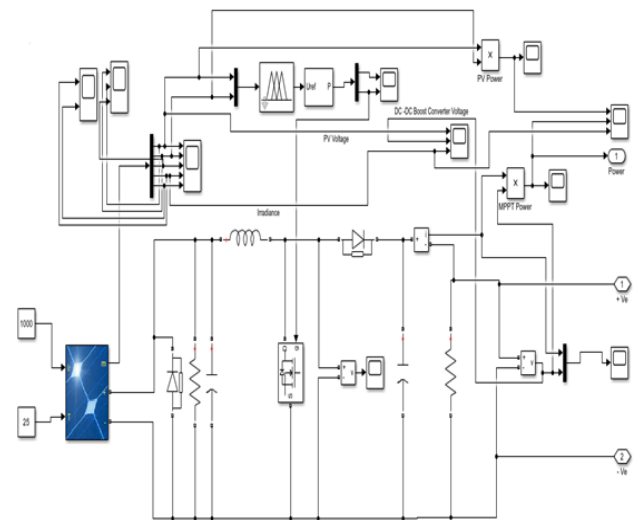
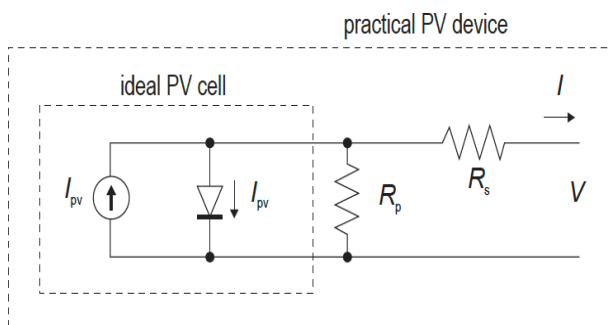

Fig 3: The Simulink model of the PV array.

B. Fuzzy Logic Control

A (FLC) approach has grown in popularity over the past decade since it does not need a perfect mathematical formula and therefore can cope with lead to poor results and non - linearities. The fuzzy logic controller is utilized in this approach to indicate the progressive current capacity in the existing operation of MPPT.

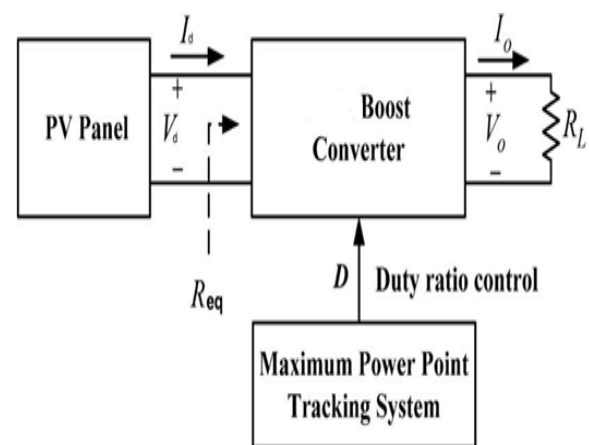

Fig 4: A PV array with a boost converter.

A (FLC) approach has grown in popularity over the past decade since it does not need a perfect mathematical formula and therefore can cope with assumptions that affect demographic assumptions and nonlinear effects. The control's fuzzy logic is used in this approach to indicate the incrementally original capacity in the previous directive of MPPT. As a result,

Sr No	MATLAB Simulation block	Parameters Specification
1	Solar PV System	Power output = 100 KW
2	Wind energy system	Output dc current = 100 A; Output dc power = 35 KW
3	Battery energy system	Voltage = 48 V; Ampere hour rating =600 Ah; Power = 29 KW
4	Universal bridge (Inverter)	Snubber resistance = 100000 ohm; Ron =1 mOhm
5	Three phase transformer (Inductance Matrix Type)	Nominal power = 100 KVA; Frequency = 50 Hz; Primary Voltage =63 KV; Secondary voltage = 0.25 KV
6	PMSG	RPM =3000 rpm; Torque = 126 Nm; Stator phase resistance = 0.05 ohm; Armature inductance = 0.000635 Henry
7	Local three phase load	Nominal phase to phase voltage Vn = 440 V; Nominal frequency = 50 Hz; Active Power = 50 KW; Inductive reactive power = 100 VAr; Capacitive reactive power= 100 VAr

the FLC technology's MPP converging time is faster than that of the P&O methodology's. The downside of I. MATLAB Simulation Model Parameters

the (FLC) approach is that its operation is reliant on the developer's talents rather than finding the correct error calculation.

Simulation software created the boost converter illustrated in Fig 5.

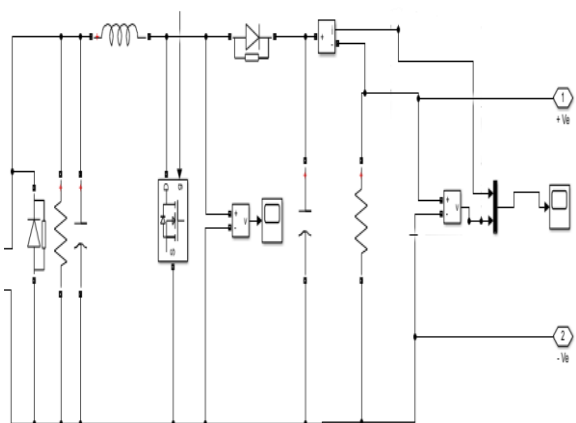

Fig 5: The Simulink model of the boost converter.

C. Wind System Simulation

Electricity production accounts one for about 1% of

solar radiation overall that reaches our planet. Wind is described as the rocking motion moving air molecules, and its speed & directions may be calculated. This migration is caused by variations in air pressure

caused by solar radiation of specific bits of the Troposphere. As a result, wind may be thought of as an intermediate kind of sun's electricity. Because air travels both vertically and horizontally, only the diagonal movement is considered winds.

Such organization consists of a windfarm that transforms the energy from wind towards spinning movements, a transmission that adjusts the angular velocity to the rotational velocity to obtain the necessary performance, and a generating that transfers electrical power into mechanical energy. It also has a rectifier to change AC toward DC, a DC-DC converters, and an MPPT touchscreen toward calculate MPP. Fig 6 shows a block schematic of the system for wind energy [7].

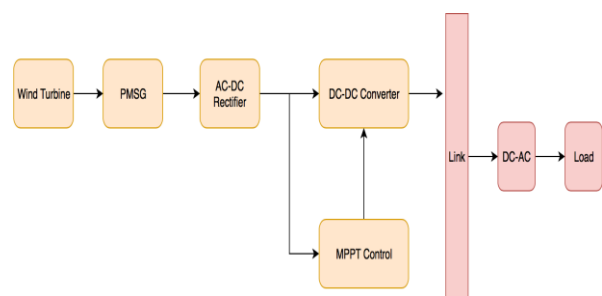

Fig 6: The proposed wind energy system.

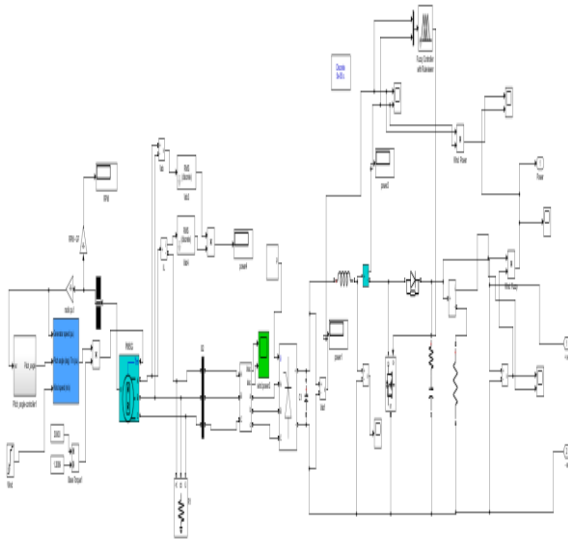

Fig 7: Simulink model of Wind Energy System

Windfarms are devices that collect wind and solar and are classed according to the position of various propellers in relation to the aerodynamic forces. Wind energy are categorized into two types: counterclockwise rotation propellers and rotational symmetry generators. Horizontal-axis propellers are the most prevalent kind of generator utilized both in big and small electricity production [13]. Highlighted that the PMSG has a shorter dimensions and a lesser moment of inertia as compared to induction generators, which results in improved dependability and a greater energy density per volume ratio [14].

D. Battery System Simulation

Batteries are classified depending on their present kinds. Turbines can run on either direct current or alternating current. The generated voltage is alternating current in both cases (AC). By introducing a generator, it may be converted to produce electricity. Synchronous generators may also be classed depending on rotor position. Here remain 2 kinds of AC producers suited for wind and solar: synchronization generating and inducement generators. Although both the (DFIG) and the (PMSG) are suitable for wind-powered systems, the PMSG will be employed to lower supply requirements [7]. The battery functions as a storage device for extra electrical energy and as a power source. In this thesis, the PV and wind power systems, as well as a fuzzy logic controller (FLC), are coupled to the battery storage system. The FLC controls the power flow across the entire hybrid system. The battery storage system should have a multidirectional power flow. As a result, whether there

is an excess or shortage of power, a bidirectional converter is needed to charge and discharge the battery [7]. Block representation of the battery storage system is shown in following Fig 8.

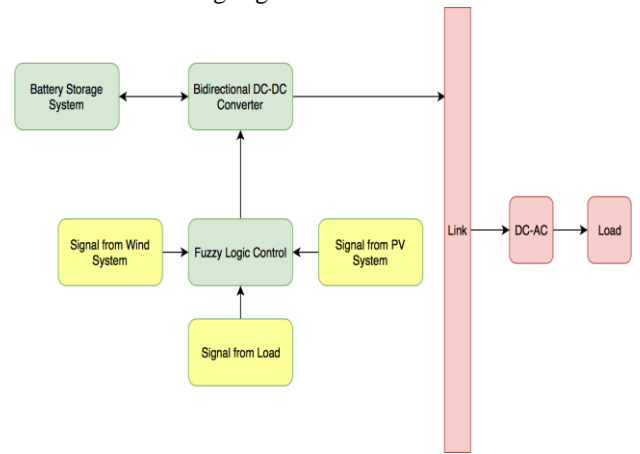

Fig 8: The battery storage system.

DC-DC Impedance matching Transceiver

Reversible Distribution transformers are so named because they enable electricity to flow in both channels. Those conversion are used in a spectrum of uses, including (UPS), energy memory devices, and renewable energy generation systems. Depending on the system's architecture, simultaneous DC-DC converters are classed as buck or boost. The boost variety is connected to the lower range, while the buck variety is connected to the large side. Bi - directional power DC-DC converters are classified into two categories based on the insulation among the output and the input nondisplaced and connected [7]. Fig 9 [15] depicts the overall circuit topology among most reversible Dc conversion.

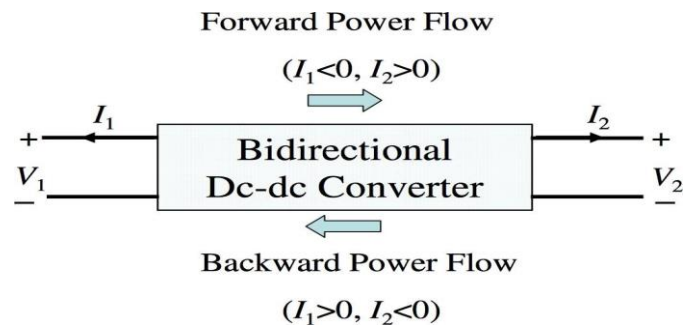

Fig 9: Bidirectional power flow.

As illustrated in the diagram, the bilateral DC-DC converter is linked to the charger as well as the FLC Fig 10.

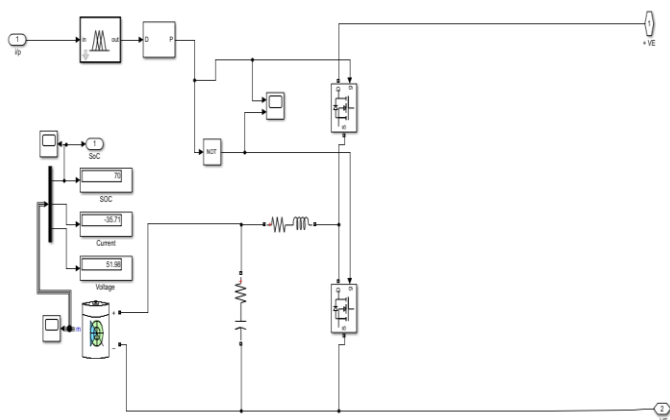

Fig 10: The Simulink model of the bidirectional DC-DC converter

Power Saving Technique Using Model Predictive Monitoring . The active interplay among the PV / diesel network, electronic control translators, & loads might cause difficulties with data integrity or lower maximum energy reliability. As a result, regulator besides administration of the electricity delivery organization remain crucial there in mixture version.

Design of the Battery System Controller

As seen in the figure, this controller's fuzzy judgement is used to regulate the both accusing then clearing modes of the mixture organization proposed Fig 9. The variable structure component is Mistake (P), and it may be calculated by using the following equation:

$$Error(\Delta P) = P_{PV} + P_{Wind} - P_{Load} \tag{2}$$

where:

P_{PV} is the photometric program's total power.

P_{wind} Capability to make is the amount of electricity that the wind energy system.

P_{load} denotes the power demand.

Whenever Performance (P) is a real number, the controlscheme is recharging, and when it's a lower number, the control scheme is discharged

III. SIMULATION AND RESULTS

The control scheme determination remain evaluated in this research employing MATLAB/Simulink. To demonstrate the robustness of the hybrid energy system, 3 major conditions are modelled. The Schematic illustration of the plug - in mixture organization is represented in Fig 11.

The following is the scenario when just the PV organization is turned happening then the winds & lithium components are turned off altogether. The sun radiation ranges from 250 to 1000 w/m² but will be in the intermediate to high category. The temperature typically 25 degrees Celsius.

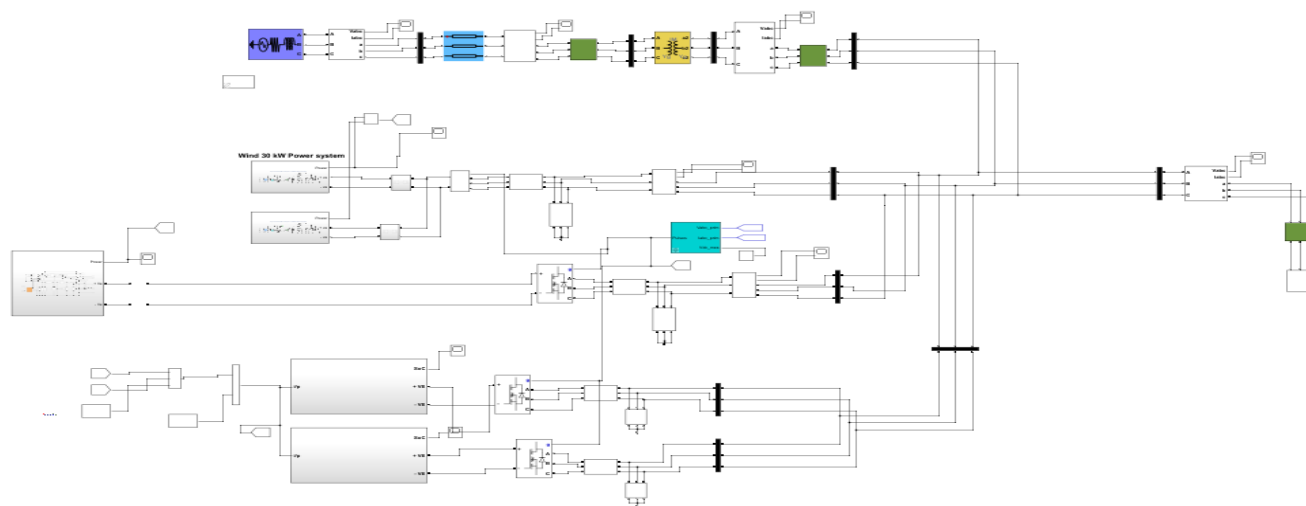

Fig 11: The Simulink model of the entire hybrid system

The demand frequency is adjusted to 50 Hz. Despite the fact that the wind velocity is zero (off) and the irradiance & temperatures are varied, the load demand remains unchanged seen in Fig 12. The PV module's real rated current is roughly 440 A, with a 230 V voltage.

The solar array's power output is 100 KW. Following calculation, fuzzy MPPT power is produced is about 104 KW. As a result, the productivity is somewhere everywhere 100 %, as illustrated in Fig 14.

Because when renewable power transistor is powered on, most other components are turned off. Wind speeds is 12 m/s. The load demand remains constant with various wind direction, as seen in Fig 15.

Fig 12: The PV array's generated voltage and current under Irradiance and Temperature

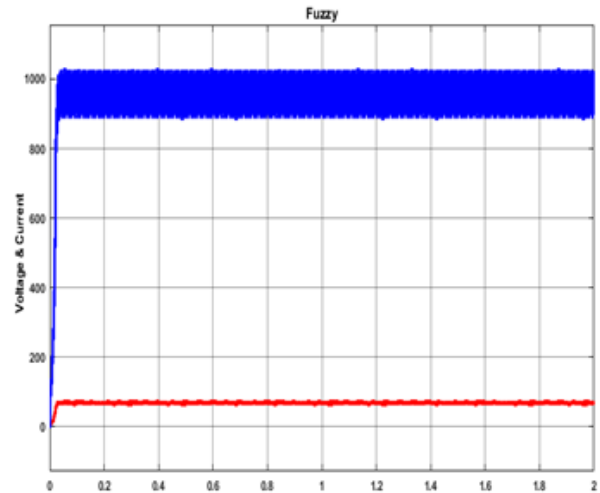

Fig 13: DC-DC boost Converted Voltage and Current of PV Array

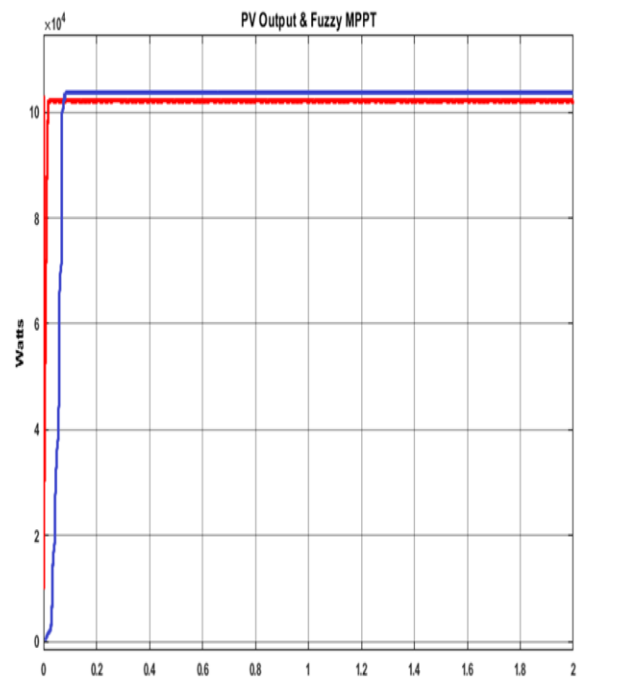
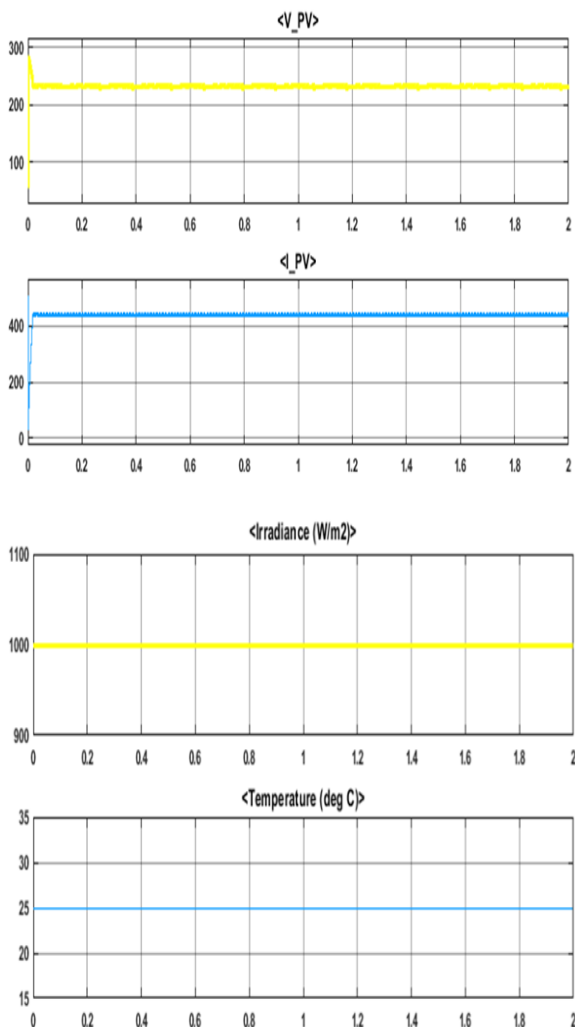

Fig 14: The PV array's Output Power and Fuzzy MPPT PV output power from the DC-DC converter

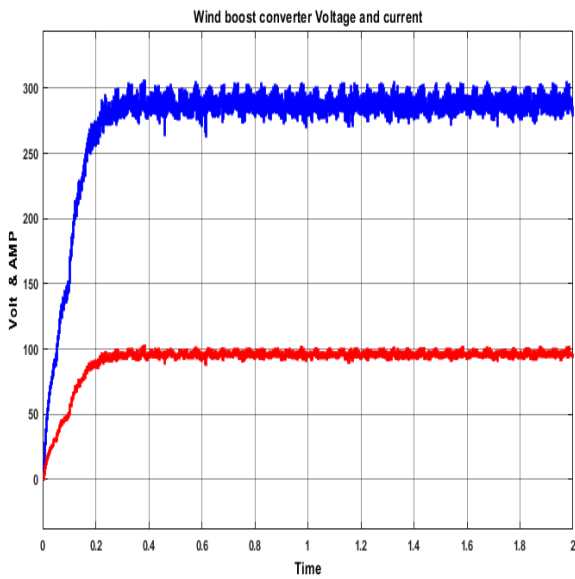

Fig 15: The Wind Boost Converter voltage and current under wind speed.

Only after PMSG, the supreme energy price remains roughly 35 KW, while the supreme ANFIS and MPPT power is 30 KW and 36 KW. As a result, the planned renewable power infrastructure will have an effectiveness of 85 % and 100 %, as demonstrated in figure 15 and figure 16. This productivity only applies to electricity supply well after PMSG. It does not apply to wind turbines since their performance is determined by mechanical motion and many other considerations

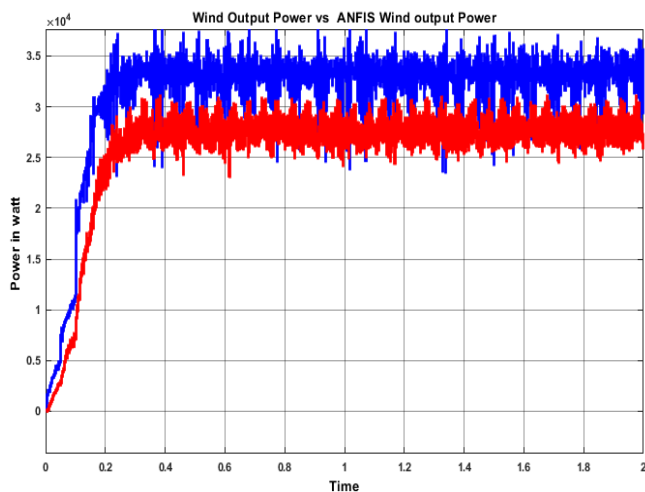

Fig 16: Wind output power Verses ANFIS wind output power

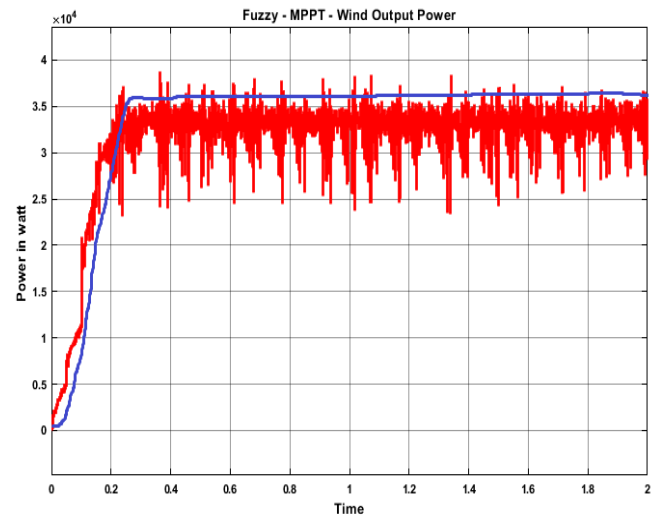

Fig 17: Wind and Fuzzy MPPT Output Power.

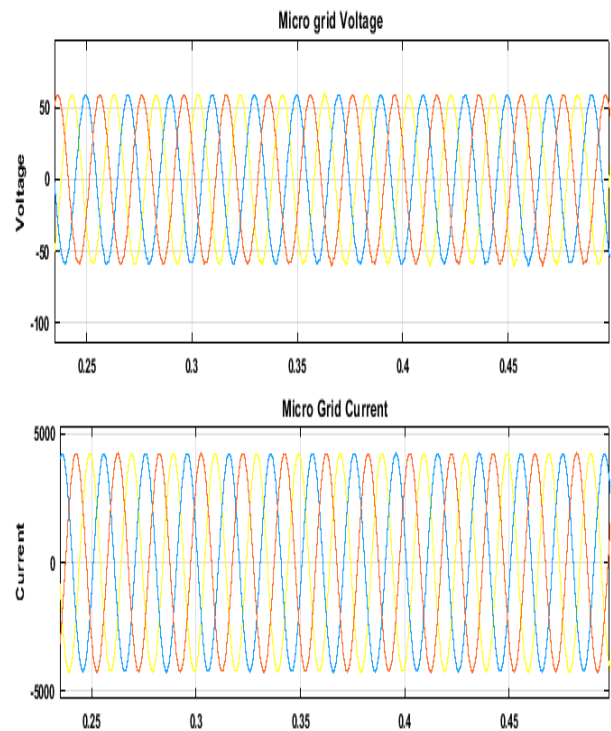

Fig 18: Micro grid side voltage and current

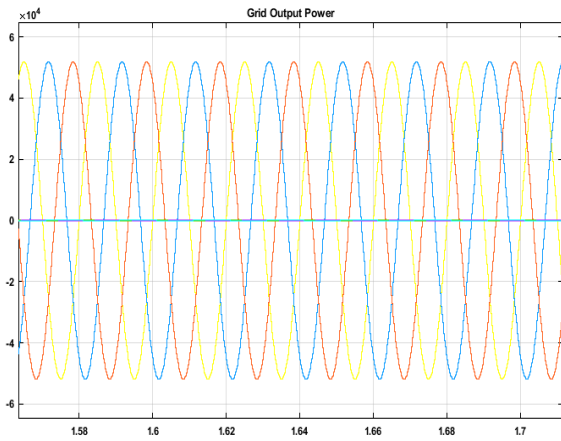

Fig 19: Grid output Power

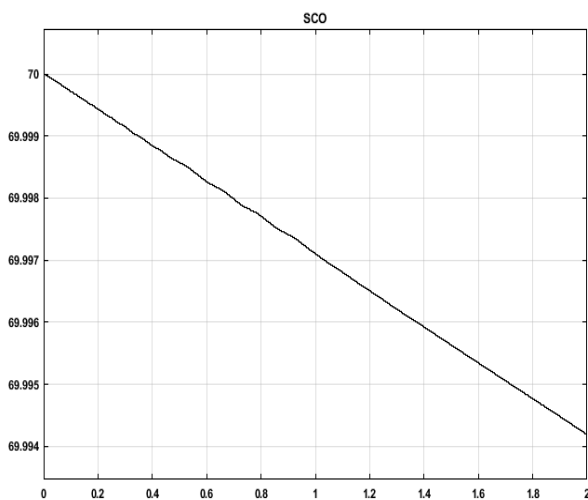

Fig 20: The condition of the battery SCO during discharging mode under various radiation, temperature, wind and PV conditions

A hybrid Power combination with battery bank was constructed and modelled in this research. The Power generation, as well as the windfarm and battery storage systems, have been investigated separately. Following that, the complete suggested boost converter was researched and developed.

II. Total Harmonics Distortion

Parameters	THD %
Grid Voltage	0.74
Grid Current	0.04
Grid Power output	0.25

IV. CONCLUSION

MPPT processors have been used in PV and wind systems to monitor the highest point of power. The fuzzy MPPT approach and a voltage regulator were employed in the PV system to change the pulse width

and acquire the MPP.

A PMSG was employed in the wind energy conversion system to change the electromechanical energy productivity of the windfarm hooked on electric influence. Following the AC-DC transformation, the MPP was obtained using the Fuzzy MPPT method and a voltage regulator.

To preserve added energy & send electricity to the application, a battery management technology with a bidirectional DC-DC converter was employed. In the battery bank, an FLC was used to manage the charge and discharge processes. Additional FLC was also employed to regulate and alter the illumination and air velocity.

Simulation software was used to develop and analyze the full mixed powertrain throughout fixed climate situations and operating modes.

It may be inferred that using a combination system by combining a Solar and wind generator equipment with an energy storage system is so much more economic and dependable than using a single PV or renewable energy system. Implementing additional mixed powertrain with a different power management model might be an interesting future subject. MPP may also be monitored employing various highly efficient techniques.

V. REFERENCE

[1] Muralikrishna, M., and V. Lakshminarayana. "Hybrid (solar and wind) energy systems for rural electrification." ARPN Journal of Engineering and Applied Sciences 3, no. 5 (2008): 50-58.

[2] Kjellander, Matilda, and Anders Tengvall. " Design of a small scale hybrid photovoltaic and wind energy system. " BSc thesis, Halmstad University, 2014.

[3] Faisal, Hiba. " Hybrid wind-solar electric power system. " BSc diss., University of Khartoum, 2014.

[4] EIA, US. " Annual energy outlook 2016. " US, Energy Information Administration, Washington, DC (2016).

[5] REN21, Renewables. " Global Status Report, Paris, REN21 Secretariat, 2016. " (2016).

[6] Negi, Swati, and Lini Mathew. " Hybrid renewable energy system: a review. " Int J Electron Electr Eng 7 (2014): 8.

[7] Kumar, Sandeep. " Modeling and simulation of hybrid Wind/Photovoltaic Stand-alone generation system. " Master’s thesis, National Institute

Technology, 2014.

[8] Patel, Sanjukta. & quot; Modeling and control of a grid connected wind-PV hybrid generation system. & quot; Master's thesis, National Institute Technology, 2014.

[9] MHUSA, NICHOLAUS JOSEPH. & quot; Modeling and Control of Photovoltaic-Wind Hybrid Power System Using a Neural-Fuzzy Controller. & quot; PhD diss., COHRED, JKUAT, 2016.

[10] Ovaska, Seppo. & quot; Maximum power point tracking algorithms for photovoltaic applications. & quot; PhD diss., Aalto University, 2010.

[11] Rolan, Alejandro, Alvaro Luna, Gerardo Vazquez, Daniel Aguilar, and Gustavo Azevedo. & quot; Modeling of a variable speed wind turbine with a permanent magnet synchronous generator. & quot; In *Industrial Electronics, 2009. ISIE 2009. IEEE International Symposium on*, pp. 734-739. IEEE, 2009.

[12] Breza, Paraskevi. & quot; Modelling and simulation of a PV generator for applications on distributed generation systems. & quot; PhD diss., TU Delft, Delft University of Technology, 2013.

[13] Blazev, Anco S. *Photovoltaics for commercial and utilities power generation*. Lulu Press, Inc, 2013.

[14] Upadhyay, S. K., Sudhanshu Tripathi, Neeraj Singh, and Gaurav Srivastava, "Optimization and Control of a Variable Speed Wind Turbine with a Permanent Magnet Synchronous Generator," in *International Journal of Engineering Trends and Technology (IJETT)*, vol. 4, pp. 2620-2627, June 2013.

[15] Villalva, Marcelo Gradella, Jonas Rafael Gazoli, and Ernesto Ruppert Filho. & quot; Comprehensive approach to modeling and simulation of photovoltaic arrays. & quot; *IEEE Transactions on power electronics* 24, no. 5 (2009): 1198-1208.