



## Implementation of Looped Heat Pipe in Room Air Conditioner for Increase in Efficiency

Rajesh Kumar<sup>1</sup>, Dr. Shrihar Pandey<sup>2</sup>

<sup>1</sup>Research Scholar, Eklavya University

<sup>2</sup>Associate Professor, ME, Eklavya University

raaj081988@gmail.com

**Abstract-** The heating, ventilation, and air conditioning (HVAC) business offers solutions to enhance thermal comfort in people's daily lives. Traditional air conditioners and air coolers are frequently used to lower a room's temperature. The purpose of this senior project is to investigate the idea of a heat pipe air conditioner (HPAC). While air conditioners are devices that actively remove heat from a place by superheating their refrigerant, heat pipes are passive heat transfer devices that rely on the phase change of their working fluid to do so. A heat pipe will be able to actively transfer heat thanks to the hybridization of the two components. This senior year study will pique the interest of other scholars to further develop the current model once the idea of HPAC has been proven. In the HVAC business, the HPAC may theoretically be launched as a less expensive and more energy-efficient alternative to air conditioners and air coolers. To validate the notion, two approaches were developed. One approach was creating a mathematical model to analyse the HPAC's thermodynamic cycle. To test the cooling capabilities of the HPAC under real-world circumstances, a prototype was also built. The mathematical model demonstrates that heat transfer will occur when the evaporator and condenser pressures are adjusted to the correct saturation pressure of the working fluid. However, according to the experiment, when isopropyl alcohol is employed as the working fluid, the evaporator experiences a large rise in temperature over time at low evaporator pressure (absolute pressure: 26 kPa to 60 kPa).

**Keywords**— *Looped Heat Pipe, Room Air Conditioner, Increase in Efficiency, HPAC, Hybridization.*

### INTRODUCTION

A major point of contention is how to balance the impact of human behaviour on the health of the earth. The reckless lifestyles of people all over the world and their disregard for the effects they have on the environment are repeatedly blamed in scientific publications about global warming. On the other hand, economic lobby groups and large corporations argue that the last thirty to forty years of the electronic revolution have altered daily life, which is largely dependent on the use of technology, and that this demonstrates how they participate in, put forth great effort in, and support efforts to combat global warming. However, energy use has increased every year for generations, and the future will be the same. In hot and dry countries, where air conditioning systems are widely used throughout the summer months, the situation gets worse. Even though air conditioning systems have seen significant improvements utilising various types of refrigerants and improving processes, utilising AC systems still accounts for a sizable amount of household and workplace electricity bills. In order to follow the principles of the refrigeration cycle, the AC system basically uses power to circulate the refrigerant between low and high pressure. The temperature at the input and output of a compressor, which performs circulation, is one of the factors affecting its efficiency. The refrigerant must be compressed from a superheated temperature at low pressure (evaporator pressure) to a maximum superheated temperature at high pressure (condenser pressure). The larger the difference, the better the performance, but the higher the power consumption. By heating the suction pipeline before and after the evaporator zone, before the compressor input, one can increase the compression process by achieving an extra superheated temperature at the low-pressure side. A heat pipe

could be used for this, as it is a heat-exchanger that transfers heat between its two ends without the use of mechanical or electrical power by utilising the physical characteristics of the working fluid. Applications for heat pipes are numerous and rely on their efficiency at transferring heat, including heat recovery, solar energy storage using phase change materials, and photovoltaic cooling systems. Heat pipes are frequently employed in central air conditioning systems due to their advantages in terms of better thermal conductivity, stable qualities, compact structure, and ease of control. Therefore, scientists are concentrating on increasing the heat pipe's effectiveness and creating a new type of heat pipe. The gravitational heat pipe was demonstrated to have a highly potent experimental effect in studies on heat enhancement and heat transfer simulation. The majority of studies have concentrated on developing a new type of annular heat pipe while taking into account a number of characteristics and parameters, including a contemporary capillary wick, an improved capillary structure, high-rank loop heat pipes (LHP), cryogenic or hybrid evaporators, and other cutting-edge LHP technologies. According to tests using bronze-ultrapure water HP, the LHP with a dual-channel flat has a greater overall thermal resistance than the LHP with a single channel, which is over 20% less under different power supply.

### LITERATURE REVIEW

A device called an air conditioner is used to regulate the humidity and temperature of a closed space (Legg, 2017). The functions of the air conditioner included heating, cooling, humidifying, and dehumidifying in order to maintain the setpoint conditions. For example, cooling and dehumidification or heating and humidification may be coupled in some applications to get the desired results (Cengel and Bole, 2015).

The majority of air conditioners, irrespective of the type, run on a vapour compression cycle (Chua et al., 2021). The refrigerant's phase change was necessary for the vapour compression cycle to work. In order to achieve heat transfer, a compressor raises the refrigerant's temperature and pressure until it reaches the superheated steam phase at the condenser's entry. In the condenser, heat is expelled. By passing via an expansion valve, the refrigerant's temperature and pressure are subsequently decreased. Because ambient heat entered the evaporator because the refrigerant was introduced at a lower temperature than the surroundings, the area was cooled (Borgnakke and Sonntag, 2019). The schematic diagram and thermodynamic cycle of a vapour compression cycle are shown in Figure 1.

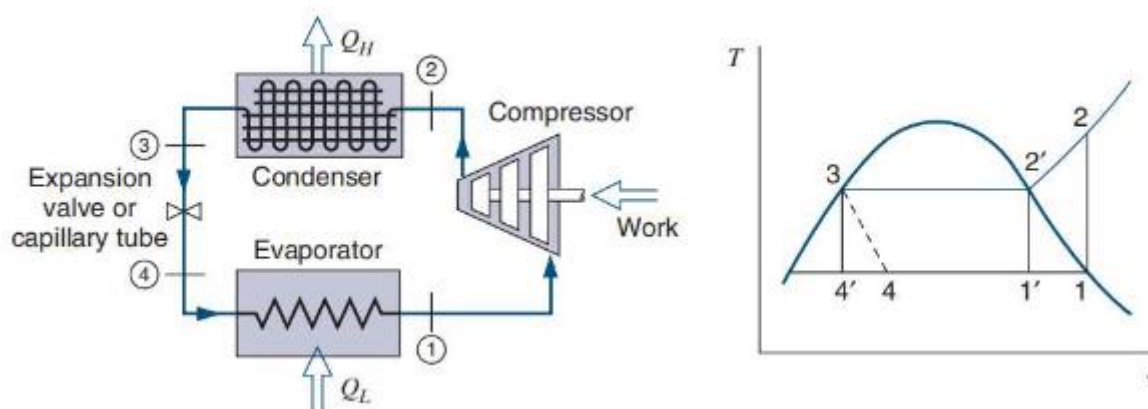

**Figure 1- Schematic diagram and Temperature-Entropy diagram of vapor compression cycle**

There are many uses for air conditioners, including single split and multi-split units in residential homes, air handling units and Variable Refrigerant Volume systems in commercial buildings, and CRAC units in data centres (Capozzoli and Primiceri, 2015; Shahsavar Goldanlou, Kalbasi, and Afrand, 2020; Wan et al., 2020).

The heat pipe is one of the gadgets of importance. A heat pipe is a device that passively transfers heat from a hot medium to a colder medium by utilising the characteristics of fluid phase change (Zohuri,

2016). A fundamental heat pipe was composed of a sealed, vacuumed envelope with working fluid inside and a wick structure laced around the interior walls. Figure 2 operating concept can be briefly summarised as follows:

1. Heat vaporised the liquid phase working fluid inside the evaporator.
2. Working fluid vaporised from the wick and made its way through an adiabatic portion to the condenser section.
3. The vapour working fluid at the condenser section releases heat, which is then condensed back into liquid phase and delivered to the evaporator via wick structure via capillary action.

With little heat loss, heat pipes may nearly instantly transmit heat over a distance (Barrak, 2021). As a result, heat pipes are used in a wide range of systems, including those that drive heat exchangers and solar thermal water heaters for heating and cooling electronics (Zohuri, 2020). The many types of heat pipes available for diverse applications include pulsating heat pipes, spinning and revolving heat pipes, capillary pumped loop and loop heat pipes (Zohuri, 2016).

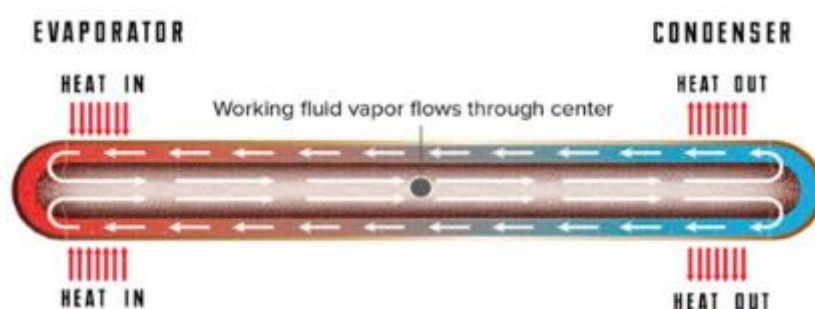
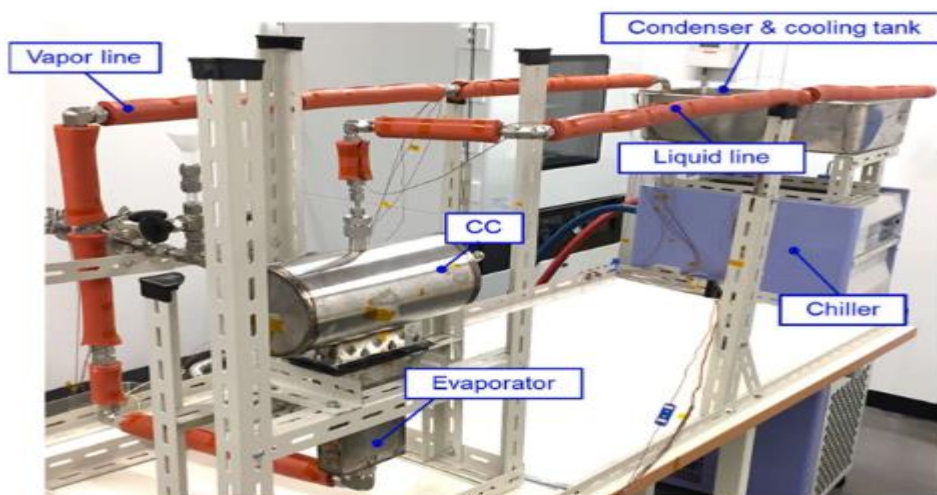

Figure 2- Schematic diagram of heat pipe

Aono et al. (2021) looked into the use of LHP, which has the capacity to transport kilowatts of heat. The working fluid for the LHP is water, and stainless steel was employed in its construction. The condenser tube diameter in the experiment ranged from 1/2 inch to 3/4 inch. The findings indicated that under natural water convection, the LHP with a 1/2-inch condenser tube has the highest heat transmission capability of 6200 W. The experimental configuration of their kW-class LHP is depicted on Figure 3.

Zhang et al. (2020a); Zhou, Wei, and Ma (2017); and Setyawan et al. (2019) created a pump-driven LHP in an effort to get over the limitations of standard LHP's heat transfer, such as temperature fluctuations and short heat transfer distances. The pump was integrated between the evaporator and the compensation chamber in the three studies. The pump helped the working fluid flow, improved heat transmission, and maintained the operating temperature.



**Figure 3- Experimental setup of kW-class LHP**

Zhang et al. (2020a) chose a centrifugal pump that can provide 90 kPa of water pressure and a flow rate of up to 2 L/min. The LHP with integrated pump's schematic diagram is shown in Figure 4. As it prevents cavitation, which may potentially harm the pump and is appropriate for the researcher's application (Operating temperature: 60 °C to +60 °C), ammonia was chosen as the working fluid. The diaphragm pump used by Setyawan et al. (2019) has a flow rate range of 40 ml/min to 100 ml/min. According to Setyawan et al. (2019), the diaphragm pump was utilised to prevent dry-out conditions in the LHP's evaporator portion.

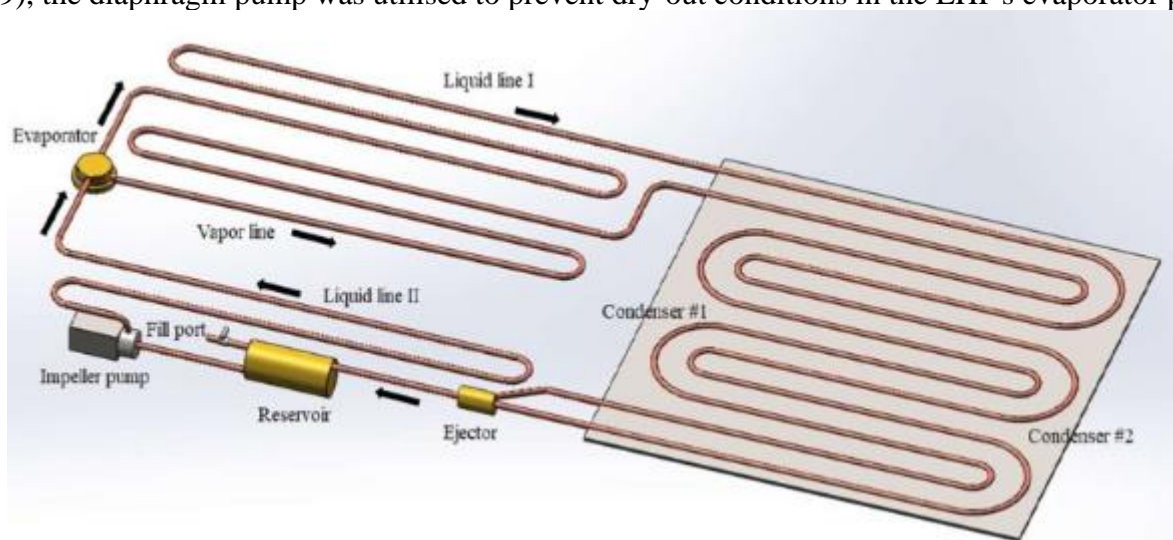

**Figure 4- Diagram of the pump assisted LHP**

According to Zhang et al. (2020) and Setyawan et al. (2019), adding a pump to the LHP improves heat transfer efficiency and reduces operating temperature. According to Zhang et al. (2020), adding a pump to an LHP will help it operate more quickly when there is little heat load. However, Setyawan et al. (2019) came to the conclusion that an integrated pump does not offer appreciable advantages at low heat loads. A pump-driven LHP was created by Zhou, Wei, and Ma (2017) to be used as energy recovery ventilators in buildings. The chosen pump has a 1.0 kW power rating, a maximum water head of 57 m, and a volumetric flow rate of 3 m<sup>3</sup>/hr; R32 was employed as the working fluid. In their 2017 article, Zhou, Wei, and Ma outlined the advantages of using pump-assisted loop heat in data centres, including energy savings over air conditioning.



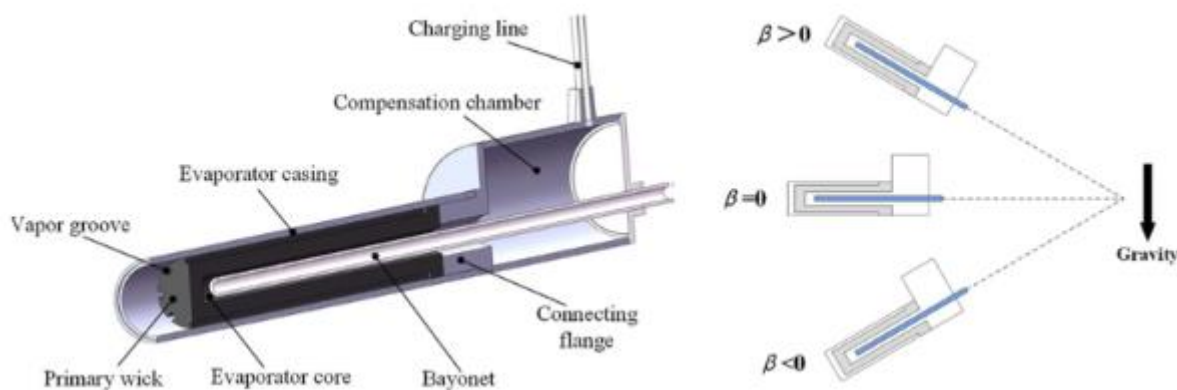

**Figure 5- Cross sectional view of the CC and evaporator of LHP and the tilt angle of the LHP**

Su et al.'s (2019) experimental investigation examined the viability of using LHP as an anti-icing and hydraulic cooling system for aircrafts. The working fluid utilised is a mixture of 60% ethanol and 40% water, which prevents the working fluid from freezing at sub-zero temperatures and takes advantage of water's excellent heat transmission capabilities. The scientists deduced from the experimental results that LHP has excellent applicability in aeroplanes as an anti-icing technology.

The performance of LHP was examined by Wang et al. (2019) in relation to non-condensable gas and evaporator tilt. The cross sectional image of the LHP's evaporator and compensation chamber (CC) is seen in Figure 2.3. The tilt angle of the LHP with regard to the direction of gravity is likewise depicted in Figure 5. Despite the presence or absence of non-condensable gas, the scientists found that LHP functioned best when tilted at  $+15^\circ$  and poorest when tilted at  $-15^\circ$ . Non-condensable gas generally reduced the heat transfer performance of LHP since it tends to raise the working temperature, but poor evaporator tilt circumstances may have a greater impact on the heat transfer capabilities.

### STRUCTURE OF LOOP HEAT PIPE

The evaporator, wick, condenser, transport line, and compensation chamber are the five essential parts of LHP (Zohuri, 2016; Guo, 2019). The evaporator's inside walls are lined with wick. According to Zohuri (2016), the wick is a porous structure that holds working fluid in the liquid state. Heat was transmitted to the wick by the evaporator envelope after entering the LHP. Due to its hydrodynamic and thermal coupling to the evaporator's core, the compensation chamber can be viewed as an extension of that core (Ambirajan et al., 2012). A reservoir that can handle the fluid volume for two uses is a compensating chamber. Compensation chamber adjusts for changes in density when the working fluid's temperature changes (Ambirajan et al., 2012). The variation of conductor conductance is made possible by the compensation chamber being either replenished or receiving working fluid from the condenser depending on the heat load (Ambirajan et al., 2012; Zohuri, 2016). Depending on the application, a condenser in an LHP may be a traditional heat exchanger like an air-cooled, pipe-in-pipe, or plate heat exchanger (Edreis and Petrov, 2020). Through the heat exchanger, the vapour phase working fluid transferred heat to a heat sink. The vapour and liquid lines made up the transport line. Transport pipes with a smoother wall connect the condenser and evaporator. According to Ambirajan et al. (2012), vapour phase working fluid is transported from the evaporator to the condenser via vapour line, and liquid phase working fluid is transported from the condenser to the compensation chamber by liquid line. The parts of a tiny LHP are shown in Figure 6.

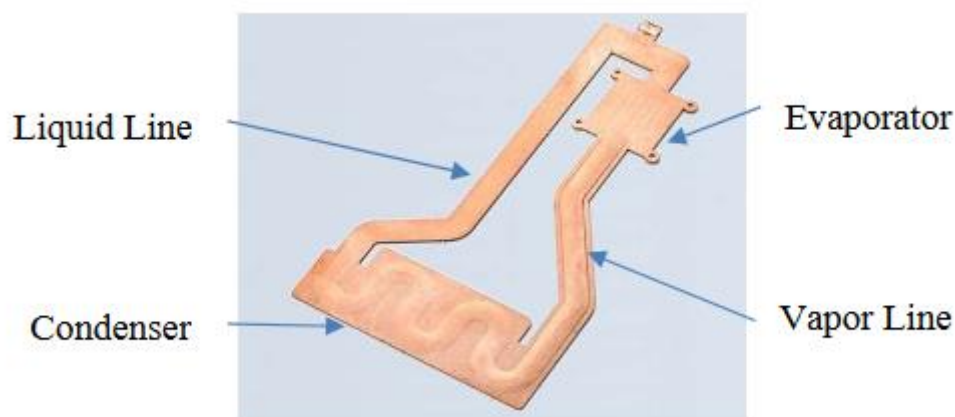

Figure 6- Miniature LHP

### AIR CONDITIONING PROCESS

Four processes make up air conditioning in general: cooling, heating, humidifying, and dehumidifying. However, when talking about air conditioning for human comfort, cooling and dehumidifying are typically spoken together. Therefore, only the two procedures will be covered in this section. By circulating the air through a series of coils containing refrigerant, it is possible to lower the air's dry bulb temperature as part of the cooling process. A cooling procedure that maintains a constant specific humidity will raise the air's relative humidity, making the user uncomfortable. So after cooling, dehumidification is done to solve this problem. The air had to be chilled below its dew point temperature in order to dehumidify. This can be done by keeping the conditioned air inside the cooling part for a long enough time to chill it to dew point. The psychrometric chart in Figure 7 can be used to explain the cooling and dehumidifying process.

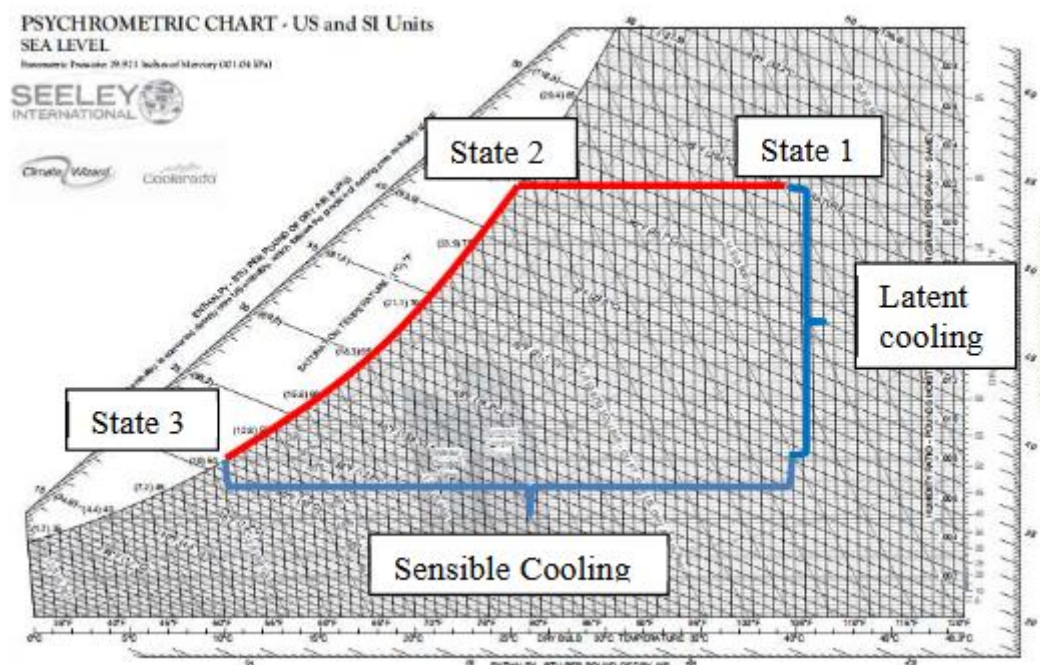

Figure 7- Psychrometric chart for cooling and dehumidification process

As seen in Figure 7, state 1 of the air conditioner is where hot, humid air enters. From state 1 to state 2, the air underwent cooling at constant specific humidity. At state 2, the air is saturated, and any additional cooling will cause moisture to condense. This is so because at state 2, when the air's dew point temperature

was reached and its relative humidity reached 100%, the air's moisture content was at its highest. As moisture is taken out of the conditioned air, the air becomes saturated from state 2 to state 3. After being mixed with the surrounding air, the conditioned air is then returned to the conditioned room, which lowers the relative humidity and dry bulb temperature of the air there. According to the psychrometric chart, the cooling capacity of an air conditioner that is, how much heat the system can remove from a space over time may also be calculated based on the amount of moisture and heat removed from the air (Subiantoro, Ooi, and Junaidi, 2013). Therefore, the wet and dry bulb temperatures as well as the mass flow rate of air are necessary to calculate the cooling capacity (Rani et al., 2018). This is so that additional parameters like relative humidity, enthalpy, and humidity ratio may be estimated using a psychrometric chart together with dry and wet bulb temperatures. The Energy Efficiency Ratio (EER) is a matrix used to assess the effectiveness of an air conditioner. By dividing the cooling capacity by the electrical energy input necessary to accomplish the cooling capacity, EER may be calculated.

## METHODOLOGY

Building a prototype is the method used in this study to gather findings for model validation. In addition, a mathematical simulation of the heat pipe air conditioner will be carried out to assess its theoretical performance. As a result, this methodology will be divided into two parts: the mathematical modelling of the heat pipe heat exchanger and the prototyping for the heat pipe air conditioner.

**(i) Mathematical Modelling-** The maximal heat transfer rate of the HPAC was calculated theoretically as part of mathematical modelling. Theoretically, an HPAC's operating principle would correspond to a heat pipe's two-phase flow regime. However, the thermodynamic cycle of an HPAC can be further simplified since it does not have a compensating chamber. If the vacuum pump and ball valve's pressure-regulating mechanism were considered to be isentropic, without any subcooling or superheating of the working fluid, the reversed Carnot cycle would resemble the HPAC's thermodynamic cycle.

**(ii) Prototyping-** The prototype needs four key parts to be built. It displays the prototype's 3D modelling, which served as a blueprint for its actual construction. The following 10 stages will help you build the prototype heat pipe air conditioner.

1. Fabrication of heat exchangers
2. Platform Construction
3. Installation of ball valve, pressure gauge and fittings
4. Installation of vacuum pump
5. Connecting the components
6. Pressure Testing
7. Selection of Working Fluids
8. Charging
9. Vacuum Evacuation

## IMPLEMENTATION LOOPED HEAT PIPE IN ROOM AIR CONDITIONER FOR INCREASE IN EFFICIENCY

Once the prototype has been finished and the necessary charging and vacuum evacuation work has been done. The testable prototype was ready for use. Testing comes first in the experiment, then comes data processing, which is explained in more detail in the part that follows.

**(i) Testing-** The ball valve A is throttled to start the test. This creates a pressure gradient between the evaporator and condenser and enables the flow of working fluid from the helical coil copper tube condenser to the GI pipe evaporator. To guarantee that the ball valve handle is restored to the same position, ball valve A's handle position is marked. Then, the pump is started. Evaluating the heat pipe air conditioner's performance was one of the goals. The temperature differential between the evaporator and the atmosphere will be used as proof that the prototype is working in order to validate the theory.



Figure 8-Food Thermometer



Figure 9- Examples of collection of data using food thermometer

Using a food thermometer, the temperature of the evaporator, condenser, and surrounding air will be measured. As seen in Figure 9, the evaporator and condenser are in touch with the probe's tip from Figure 8. It was taken when the temperature stopped fluctuating. At the beginning of the test and every 20 minutes thereafter until 60 minutes have passed, temperatures are measured. The test was stopped after 60 minutes because prior testing revealed that the temperature does not change even after the prototype has been running for 80 minutes. It was therefore thought that the prototype had reached its steady state at 60 minutes.

**(ii) Results-** The two working fluids utilised in this test are tap water and 99.8% isopropyl alcohol. For 60 minutes, the temperatures of the evaporator, condenser, and surrounding air were measured every 20 minutes. It was plotted to show the graph of  $T$  against time.

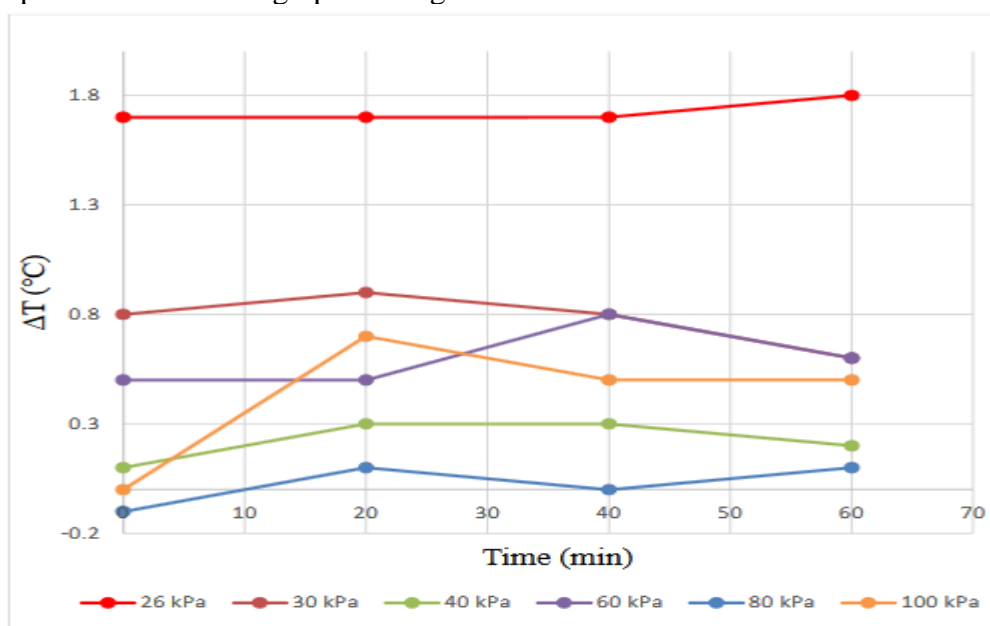



**Figure 10- Graph of  $\Delta T$  against time for various working pressure**

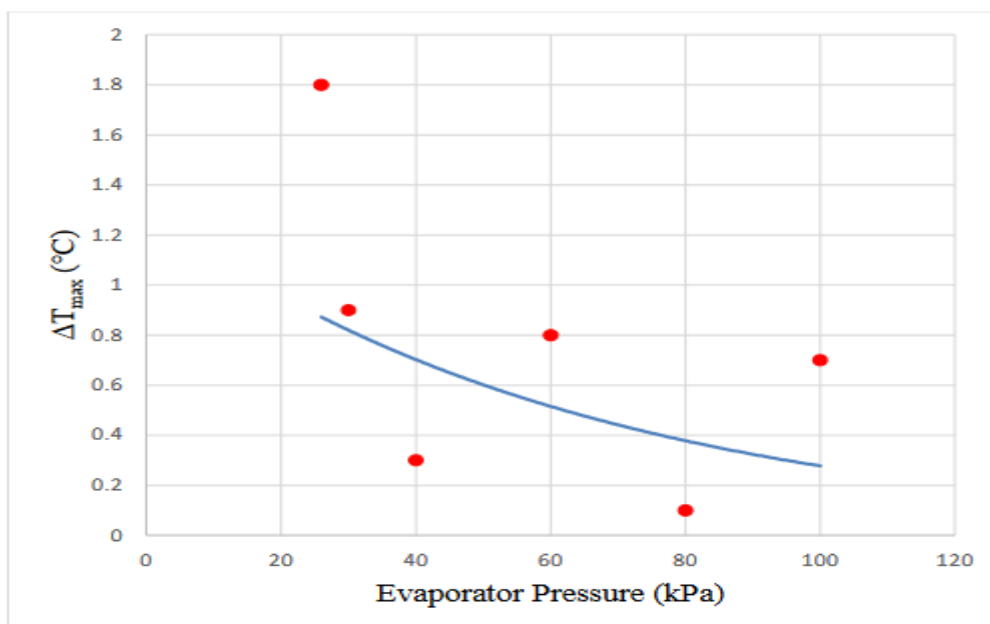

**Figure 11- Graph of  $\Delta T_{max}$  against evaporator pressure**

The graph of  $T_{max}$  against evaporator pressure was also plotted in addition to that. The temperature differential between the ambient air and the evaporator ( $T$ ), which was also indicated in section 3.2.2.10, will be regarded as a sign of how well the prototype is working.  $T$  can be thought of as the prototype's cooling capacity in simple terms. The  $T$  against time for various evaporator pressures is shown in Figures 10 and 11.

### CONCLUSION

The conclusion of this paper demonstrates the viability of the HPAC idea. This suggests that both goals were accomplished.

1. To simulate the application of heat pipes in air conditioning.
2. To plan and create a heat pipe air conditioning system proof of concept model.

Considering that the outside temperature is 30 °C. According to the mathematical modelling, the evaporator and condenser pressures must be lowered to their respective saturation pressures at the given temperature in order for heat transfer to take place. For instance, while using water as the working fluid, the evaporator pressure must be reduced to 3.1698 kPa and the condenser pressure must be increased to 5.6291 kPa in order to maintain the evaporator and condenser temperatures at 25 °C and 35 °C, respectively. When water is utilised as the working fluid, the computed heat absorption rate is 0.235 kJ/s while it is 0.072 kJ/s for isopropyl alcohol. This occurs as a result of isopropyl alcohol's greater volatility when compared to water. Isopropyl alcohol has a higher vapour pressure than water at the same temperature. It may be deduced that, at the same temperature, isopropyl alcohol will have a higher evaporation rate than water since vapour pressure has a significant positive association to a fluid's rate of evaporation. As a result, isopropyl alcohol can chill an object more effectively than water. Finally, when using isopropyl alcohol and an evaporator pressure of 26 kPa (absolute pressure), the prototype achieved the best cooling performance. This is because the maximum temperature among all other conditions the  $T$  over time is recorded at 2.5 °C. In conclusion, this senior project's goals were met, and the viability of the HPAC idea was demonstrated.

### REFERENCES

- [1]. N. Wang, J. Zhang, X. Xia Energy consumption of air conditioners at different temperature set points

Energy Build., 65 (October) (2013), pp. 412-418

[2]. A.D. Althouse, C.H. Turnquist, A.F. Bracciano, D.C. Bracciano, Bracciano Modern Refrigeration and Air Conditioning Good heart-Willcox (2021)

[3]. Adel A. Eidan, Saleh E. Najim, Jalal M. Jalil Experimental and numerical investigation of thermosyphone performance in HVAC system applications Heat Mass Tran., 52 (2016), pp. 2879-2893

[4]. Z. Li, M. Sarafraz, A. Mazinani, H. Moria, I. Tlili, T.A. Alkanhal, M. Goodarzi

Safaei. "Operation analysis, response and performance evaluation of a pulsating heat pipe for low temperature heat recovery Energy Convers. Manag., 222 (15 October 2020), p. 113230

[5]. C. Wang, S. Tang, X. Liu, G. Su, W. Tian, Qiu Experimental study on heat pipe thermoelectric generator for industrial high temperature waste heat recovery Appl. Therm. Eng., 175 (5 July 2020), p. 115299

[6]. D. Brough, A. Mezquita, S. Ferrer, C. Segarra, A. Chauhan, S. Almahmoud, N. Khordehghah, L. Ahmad, D. Middleton, H.I.J.E. Sewell An experimental study and computational validation of waste heat recovery from a lab scale ceramic kiln using a vertical multi-pass heat pipe heat exchanger Energy, 208 (1 October 2020), p. 118325

[7]. Adel A. Eidan, Assaad AlSahlani, Ahmed Qasim Ahmed, Mohamed Al-fahham, Jalal M. Jalil Improving the performance of heat pipe-evacuated tube solar collector experimentally by using Al<sub>2</sub>O<sub>3</sub> and CuO/acetone nanofluids Sol. Energy, 173 (2018), pp. 780-788.

[8]. Abdelaziz, G.B., Abdelbaky, M.A., Halim, M.A., Omara, M.E., Elkhaldy, I.A., Abdullah, A.S., Omara, Z.M., Essa, F.A., Ali, A., Sharshir, S.W., El-Said, E.M.S., Bedair, A.G. and Kabeel, A.E., 2021. Energy saving via heat pipe heat exchanger in air conditioning applications "experimental study and economic analysis." Journal of Building Engineering, [e-journal] 35.

[9]. Abdul Mujeebu, M., 2019. Introductory Chapter: Indoor Environmental Quality. In: Indoor Environmental Quality. IntechOpen.

[10]. Abdullahi, B., Al-dadah, R. and Mahmoud, S., 2019. Thermosyphon Heat Pipe Technology. In: Recent Advances in Heat Pipes [Working Title]. IntechOpen.p.13

[11]. Akanmu, W.P., Nunayon, S.S. and Eboson, U.C., 2021. Indoor environmental quality (IEQ) assessment of Nigerian university libraries: A pilot study. Energy and Built Environment, [e-journal] 2(3), pp.302–314.

[12]. Alhuyi Nazari, M., Ahmadi, M.H., Ghasempour, R., Shafii, M.B., Mahian, O., Kalogirou, S. and Wongwises, S., 2018. A review on pulsating heat pipes: From solar to cryogenic applications. Applied Energy, [e-journal] 222, pp.475–484.

[13]. Ambirajan, A., Adoni, A.A., Vaidya, J.S., Rajendran, A.A., Kumar, D. and Dutta, P., 2012. Loop heat pipes: A review of fundamentals, operation, and design. Heat Transfer Engineering, [e-journal] 33(4), pp.387–405.

[14]. Amir, A., Farid Mohamed, M., Khairul Azhar Mat Sulaiman, M. and Fatimah Mohammad Yusoff, W., 2019. Assessment of indoor thermal condition of a low-cost single story detached house: A case study in Malaysia. Alam Cipta, 12, pp.80–88.

[15]. Aono, Y., Watanabe, N., Ueno, A. and Nagano, H., 2021. Development of a loop heat pipe with kW-class heat transport capability. Applied Thermal Engineering, [e-journal] 183, p.116169.