



## THREE PHASE FAULT ANALYSIS WITH AUTO RESET ON TEMPORARY FAULT AND PERMANENT TRIP

<sup>1</sup>MADHANKUMAR M, <sup>2</sup>KEERTHIVASAN V, <sup>3</sup>Mr. ARAVINDHAN K, <sup>4</sup>Dr. CHIDAMBARARAJ N

<sup>1,2</sup>UG Student, <sup>3</sup>Assistant Professor <sup>4</sup> Associate Professor  
Department of Electrical and Electronics Engineering  
St. Joseph's College of Engineering Chennai, INDIA

[madhanshankar16@gmail.com](mailto:madhanshankar16@gmail.com) [keerthivasan738@gmail.com](mailto:keerthivasan738@gmail.com), [aravi1989nd@gmail.com](mailto:aravi1989nd@gmail.com), [mailtochidha2020@gmail.com](mailto:mailtochidha2020@gmail.com)

**Abstract**—An automatic tripping mechanism for the three-phase transmission system. In the event of a temporary fault, the output of the project resets while it acquires permanent trip condition in case of a permanent fault. There can occur several failures in a three-phase supply system that provides power to industrial and domestic consumers. These failures are results of some faults which may be temporary or permanent in nature. Due to these faults, the power system may suffer considerable damage. This can lead to disturbance in power supply and may cause a standstill to various industries linked to the system. In a three-phase power system, these faults are classified as LG (Line to Ground), LL (Line to Line), overload. This system can overcome such problem which by sensing the fault automatically and disconnects the system from the supply so that large scale damage to the system equipment can be avoided. The system automatically differentiates between a temporary disturbance and a permanent fault and A. appropriately cuts the supply for a short duration or long respectively.

**Keywords**—three-phase, fault analysis, line to line, line to ground, overload, permanent fault, temporary fault.

### I. INTRODUCTION

Three-phase fault analysis with auto reset on temporary fault and permanent trip is a method used to protect electrical systems from damage caused by faults. In electrical power systems, faults can occur due to various reasons, such as insulation failure, equipment malfunction, or external factors like lightning strikes. These faults can cause serious damage to the equipment and pose a safety hazard to personnel.

To prevent such incidents, protective relays are installed in the system, which detect and isolate the faulted section from the rest of the system. The three-phase fault analysis method is used to detect the type of fault that has occurred, whether it is a temporary fault or a permanent fault.

In the case of a temporary fault, the protective relay automatically resets the system after a brief period, as the fault is considered to be transient and not a significant threat to the system. However, in the case of a permanent fault, the protective relay trips the system to isolate the faulty section from the rest of the system until the fault is rectified.

The auto-reset feature on temporary faults ensures that the system is not unnecessarily shut down, which can cause disruption to the power supply. On the other hand, the permanent trip feature ensures that the faulty section is isolated to prevent further damage to the system and ensure safety.

Overall, the three-phase fault analysis method with auto reset on temporary faults and permanent trip is a crucial tool in protecting electrical systems from faults and ensuring reliable and safe operation.

### II. DISCRPTION OF THE SYSTEM

#### A.Introduction to the system

A fault analysis and protection system designed to detect and isolate three-phase faults in a power distribution system. The system is capable of automatically resetting in the case of temporary faults, while triggering a permanent trip for permanent faults. This ensures the system's continuity while protecting it from damage caused by permanent faults.

#### B. Proposed method of the system

The overload fault is tripped at instant and prevent equipment form damage. we use a Bluetooth module to transmit to the person when the fault occurs. When the fault occurs, the person is known when he is not inside the working area and knows whether the fault occurred or not. If it is a line-to-line fault or line-to-ground fault the system automatically resets after a specific period of time and the system comes to a normal state. If it is an overload fault the person does not know the fault occurred. In this condition, the system is designed to detect faults quickly and to trip the supply immediately, which damages the system and decreases downtime. If the downtime decreases the system becomes unstable and consumers are not affected..

### III. MODE OF OPERATION

To attain the concept, need to use Atmega328p controller, Relays, current sensor, LCD and tower. The project representing cable length in KMs and fault creation is made by a set of switches at every known KM to cross check the accuracy of the same. The voltage drop across the feeder resistor is given to an ADC which develops a precise digital

data which the programmed microcontroller would display the same in Kilometers. The fault occurring at what distance and which phase is displayed on a 16X2 LCD interfaced with the microcontroller in ground fault, distance will show on Lcd ant load cutoff automatically from the lines and a notification will send to a mobile phone using Bluetooth. If any fault occurs either in line fault or in ground fault, distance will show on Lcd ant load cutoff automatically from the lines and a notification will send to a mobile phone using Bluetooth.

1. Line to line and ground fault detection using low voltage cables. The transformer secondary will be star connected so that it will have a set of three phase lines. To analyze the fault, here we use a small circuitry called post unit, which is mounted on various points in the line. When there is short circuit between R-Y, Y-B phases then ADC get more than zero analog value at channel AD6 & AD7 where relay is in NO condition and load is stop running. The main unit also consists of set of sensors that give the status of line at that point and it accepts the information received from the post units. It sends information to the authorities of power provider about the fault including its type and location if it finds the line faulty and cut-offs the loads automatically from the lines and a notification will be sent to a mobile phone using Bluetooth.

Over load detection using Current transformer as a current sensor. The current transformers operating principle is based on the law of electromagnetic induction. This is a circuit designed to detect overcurrent. In this section a special type of CT is used to detect very low current. The output of this CT is an AC voltage proportional to the Load current. The CT voltage varies with load current. That output got rectified and compared by an op-amp and given to the microcontroller.

### A. Simulation and Result

The simulation results and discussion of this analysis with auto reset on temporary fault and permanent trip otherwise help in understanding the behavior of the power system under fault conditions. The objective of this analysis is to detect and isolate the faulted section of the power system while keeping the healthy sections operational. The auto reset feature allows the system to automatically restore the tripped circuit breaker after a temporary fault has been cleared. On the other hand, in the case of a permanent fault, the circuit breaker will remain open, resulting in a permanent trip. The simulation results will show the behavior of the system under different fault conditions and the effectiveness of the protection scheme. It will also demonstrate how the auto reset feature operates and its impact on the power system's stability.

The simulation results will include an analysis of the fault currents, voltage levels, and the time required to isolate the faulted section. The discussion will also consider the impact of the protection scheme on the power system's stability and the possibility of false trips. Overall, the simulation results and discussion of the three-phase fault analysis with auto reset on temporary fault and permanent

trip otherwise will provide valuable insights into the behavior of the power system under fault conditions and the effectiveness of the protection scheme in ensuring the system's stability and reliability

### B. Simulation Result

The simulation and result of the three-phase overload fault. When the fault occurs, the relay operates and the circuit breaker trips and the load is protected. The graphs show the voltage and current before and after the trip.

The below Fig1 shows the simulation of overload fault and Fig 2 show the obtained waveform from the simulation.

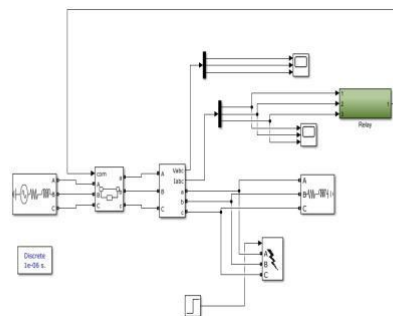

Fig.1 Simulation of the fault

### C. Obtained Waveform



Fig.2 Voltage Waveform

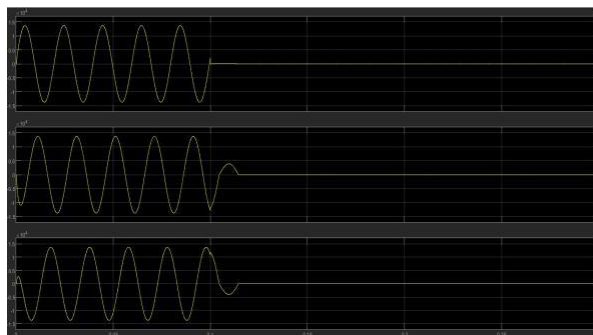

Fig.3 Current Waveform

**D. Design and Specifications**

Design specifications for a three-phase fault protection system with auto rest on for temporary faults and permanent trip for permanent faults may include the following:

**Fault detection:** The system must be able to detect the presence of a fault in the three-phase power system quickly and accurately.

**Fault classification:** The system must be able to classify the fault as either temporary or permanent and initiate the appropriate response.

**Response time:** The system must be able to respond to a fault within a specified time, typically a few milliseconds for permanent faults and a few seconds for temporary faults.

**Auto-restoration:** The system must have the capability to auto-restore after a temporary fault is cleared, without any manual intervention.

**Permanent trip:** The system must have the capability to initiate a permanent trip response when a permanent fault occurs, to disconnect the affected equipment from the power source and prevent further damage.

**Redundancy:** The system may include redundant protection elements to improve the reliability of the system.

**Communication:** The system may have communication capabilities to provide alerts and notifications to personnel in the event of a fault, as well as to enable remote monitoring and control.

**Compatibility:** The system must be compatible with the existing electrical infrastructure and equipment.

**E. Hardware Result and Discussion**

Three-phase fault analysis with auto reset on temporary fault and permanent trip otherwise is a study on electrical power system protection, specifically on the behavior of protective relays during fault conditions. This study analyzes the behavior of a three-phase protective relay when a fault occurs in the power system. The protective relay is designed to detect the fault and take appropriate actions to protect the power system from further damage.

The performance of the protective relay in two scenarios: temporary faults and permanent faults. In the case of a temporary fault, the protective relay is designed to automatically reset after a short delay to allow the power system to return to normal operation. However, in the case of a permanent fault, the protective relay will trip and isolate the faulted section of the power system.

The results and discussion of this study will provide insights into the behavior of protective relays in real-world fault conditions. The analysis will help power system engineers to design better protection schemes that can ensure the safety and reliability of the power system.

**F. Hardware Discription**

**1) ARDUINO ATMEGA328P:**

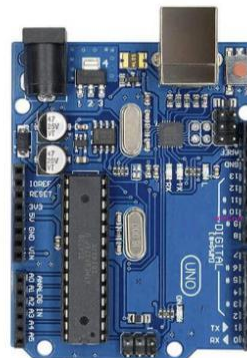

**Fig.4 ARDUINO ATMEGA328P**

The ATmega328P is the microcontroller that powers the Arduino Uno development board. The Arduino board makes it easy to interface with the pins on the ATmega328P while adding extra features that don't come with the standalone microcontroller, including a USB serial interface and 16 MHz clock. It contains everything needed to support the microcontroller; simply connect it to a computer with a USB cable or power it with an AC -to- DC adapter or battery to get started. The Fig 4 and Fig 5 shows the module of AduinoAtmega328P and pin out.

**TECHNICAL SPECIFICATION**

The technical specifications of ATmega328P.

Microcontroller	Arduino ATmega328P
Operating	5v
Digital pins	14
Analog Pins	6
Speed	0-20MHz
Core size	32 kB
Flash memory	32kB
RAM	2K x 8
EEPROM	1k x 8
Clock Speed	8MHz
IC type	AVR microcontroller

**Table.1 Technical Specification of Arduino ATmega328P**

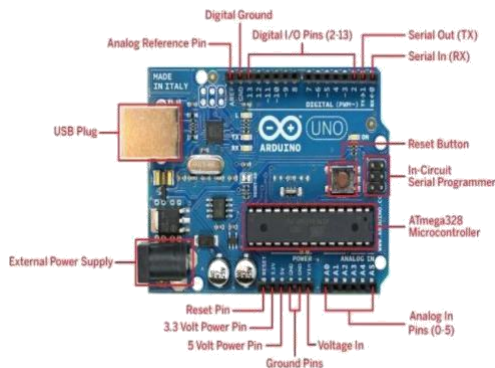

**Fig.5 Arduino Atmega328P microcontroller components**

Arduino is open-source hardware. The hardware reference designs are distributed under a Creative Commons Attribution Share-Alike 2.5 license and are available on the Arduino website. Layout and production files for some versions of the hardware are also available. Several Arduino-compatible products commercially released have avoided the project name by using various names ending in Arduino. An early Arduino board with an RS-232 serial interface (upper left) and an Atmel ATmega8 microcontroller The - ATmega328 is commonly used in many projects and autonomous systems where a simple, low-powered micro-controller is needed. Arduino UNO is a microcontroller based on the ATmega328P. It has 14 digital input/output pins (of which 6 PWM outputs), 6 analog inputs, a 16 MHz ceramic resonator, a USB connection, a power jack, an ICSP header and a reset button. 22 Most Arduino boards consist of an Atmel 8-bit AVR microcontroller (ATmega8, ATmega168, ATmega328, ATmega1280, ATmega2560) with varying amounts of flash memory, pins, and features. The 32-bit Arduino Due, based on the Atmel SAM3X8E was introduced in 2012. The boards use single or double-row pins or female headers that facilitate connections for programming and incorporation into other circuits. These may connect with add-on modules termed shields. Multiple and possibly stacked shields may be individually addressable via an I<sup>2</sup>C serial bus. Most boards include a 5 V linear regulator and a 16 MHz crystal oscillator or ceramic resonator. Some designs, such as the Lilypad, run at 8 MHz and dispense with the onboard voltage regulator due to specific form-factor restrictions. Arduino microcontrollers are pre-programmed with a boot loader that simplifies uploading of programs to the on-chip flash memory. The default bootloader of the Arduino UNO is the Opti boot bootloader. Boards are loaded with program code via a serial connection to another computer. Some serial Arduino boards contain a level shifter circuit to convert between RS-232 logic levels and transistor-transistor logic (TTL) level signals. Current Arduino boards are programmed via Universal Serial Bus (USB), implemented using USB-to-serial adapter chips such as the FTDI FT232. Some boards, such as later-model Uno boards, substitute the FTDI chip with a separate AVR chip containing USB-to-serial firmware, which is reprogrammable via its own ICSP header. Other variants, such as the Arduino Mini and the unofficial Boarduino, use a detachable USB-to-serial adapter board or cable, Bluetooth or

other methods. When used with traditional microcontroller tools, instead of the Arduino IDE, standard AVR in-system 23 programming (ISP) programming is used. An official Arduino Uno R2 with descriptions of the I/O locations. The Arduino board exposes most of the microcontroller's I/O pins for use by other circuits. The Diecimila, Duemilanove and current Uno provide 14 digital I/O pins, six of which can produce pulse-width modulated signals, and six analog inputs, which can also be used as six digital I/O pins. These pins are on the top of the board, via female 0.1-inch (2.54 mm) headers. Several plug-in application shields are also commercially available. The Arduino Nano, and Arduino-compatible Bare Bones Board and Arduino boards may provide male header pins on the underside of the board that can plug into solderless breadboards. Many Arduino-compatible and Arduino-derived boards exist. Some are functionally equivalent to an Arduino and can be used interchangeably. Many enhance the basic Arduino by adding output drivers, often for use in school-level education, to simplify making buggies and small robots. Others are electrically equivalent but change the formfactor, sometimes retaining compatibility with shields, sometimes not. Some variants use different processors, of varying compatibility.

## 2) POWER SUPPLY

### a) Transformer

A step-down transformer is a type of electrical transformer that is designed to decrease the voltage of an alternating current (AC) power source. It works by using the principle of electromagnetic induction to transfer electrical energy from one circuit to another by means of a magnetic field.

The step-down transformer consists of two coils of wire, known as the primary and secondary windings, that are wound around a common magnetic core. The primary winding is connected to the high voltage AC power source, while the secondary winding is connected to the load.

When AC voltage is applied to the primary winding, it creates a magnetic field that induces a voltage in the secondary winding. The voltage induced in the secondary winding is proportional to the ratio of the number of turns in the primary and secondary windings.

In a step-down transformer, the number of turns in the secondary winding is less than the number of turns in the primary winding, resulting in a lower output voltage than the input voltage. The amount of voltage reduction is determined by the turns ratio of the transformer. For example, a transformer with a turns ratio of 2:1 will produce an output voltage that is half of the input voltage.

Step-down transformers are commonly used in power distribution systems to reduce the voltage of high voltage transmission lines to a level that is safe for use in homes and businesses. They are also used in electronic devices, such as power supplies, to provide a low voltage DC output from a higher voltage AC input. The below Fig 6 show the circuit diagram of 230v to 5v step down transformer

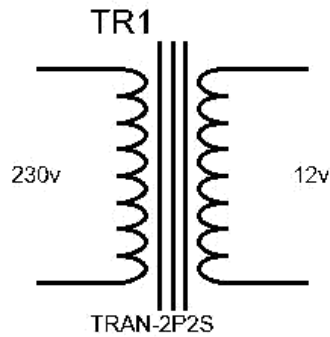

Fig.6 Step down transformer

**b) BRIDGE RECTIFIER**

A 0-12V/1 mA transformer is used for this purpose. The primary of this transformer is connected into main supply through on/off switch & fuse for protecting from overload and short circuit protection. The secondary is connected to the diodes to convert 12V AC to 12V DC voltage. And filtered by the capacitors, which is further regulated to +5v, by using IC 7805. The below Fig 7 shows the circuit diagram of Bridge rectifier

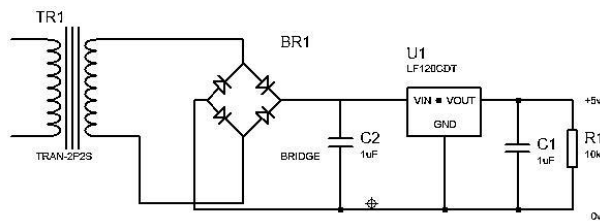

Fig.7 Bridge Rectifier

**c) Buck Boost Converter**

A buck-boost converter is a type of DC-DC converter that can produce an output voltage that is either higher or lower than the input voltage. This is achieved by regulating the duty cycle of a switching transistor, which controls the amount of energy transferred from the input to the output.

The basic operation of a buck-boost converter is as follows:

During the on-time of the switching transistor, the input voltage is applied across the inductor and the load.

The inductor stores energy during the on-time of the transistor.

During the off-time of the transistor, the inductor discharges energy into the load. The output voltage is determined by the ratio of the on-time to the off-time of the transistor.

The Buck Boost converter is used to step down the 12v DC supply to 5v and give it to Arduino ATmega328.

The Fig.8 show the circuit diagram of Buck Boost converter

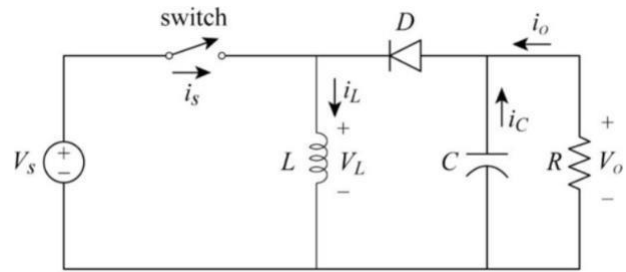

Fig.8 Buck Boost Converter

**3) LCD (Liquid Crystal Display)**

LCD screen is an electronic display module and find a wide range of applications. A 16x2 LCD display is very basic module and is very commonly used in various devices and circuits. These modules are preferred over seven segments and other multi segment LEDs. The reasons being: LCDs are economical; easily programmable; have no limitation of displaying special & even custom characters (unlike in seven segments), animations and so on.

A 16x2 LCD means it can display 16 characters per line and there are 2 such lines. In this LCD each character is displayed in 5x7 pixel matrix. This LCD has two registers, namely, Command and Data.

The command register stores the command instructions given to the LCD. A command is an instruction given to LCD to do a predefined task like initializing it, clearing its screen, setting the cursor position, controlling display etc. The data register stores the data to be displayed on the LCD. The data is the ASCII value of the character to be displayed on the LCD. Click to learn more about internal structure of an LCD.

The LCD display is used to display whether the system is stable or shows the type of fault occurred in the system.

The below Fig 9 shows the LCD module and the pin out of the LCD display.

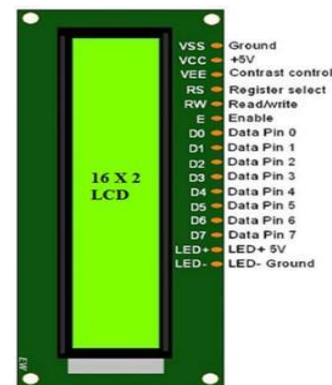

Fig 9 Pin Diagram of LCD

#### 4) Relay

A 5V 4-channel relay is an electronic component that can be used to control multiple electrical circuits or devices with a single signal. The 5V power supply is connected to the relay module to power it up.

A control signal is applied to the input terminals of the relay module. This signal can come from a microcontroller or other device that is providing the control signal.

When the control signal is applied, it energizes the coil inside the relay, which generates a magnetic field.

The magnetic field causes the metal armature of the relay to move, switching the contacts from their normally open (NO) to their normally closed (NC) position. This opens or closes the circuit, depending on the configuration of the contacts.

The NO and NC contacts are connected to the circuits or devices that need to be controlled. When the contacts switch position, they either open or close the circuit, depending on the configuration.

The relay provides electrical isolation between the control circuit and the circuit or device being controlled. This can help to protect the control circuit from high voltages, current spikes, or other electrical disturbances.

The 4-channel relay module has multiple relays, each with its own set of contacts. This allows it to control multiple circuits or devices with a single control signal.

The purpose of the relay used here is to trip when the more current passes to the load and save the equipment from damage. The Fig 10 shows the relay module and pinout of the relay module

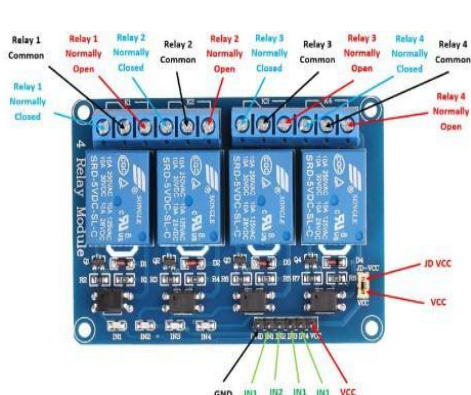

Fig 10 Relay

#### 5) OPTO COUPLER

An optocoupler that uses a diode works by using a light-emitting diode (LED) to generate light that is detected by a photodiode or phototransistor.

When a signal is applied to the input circuit, it passes through a current limiting resistor and is used to drive the LED. The LED is designed to emit light in response to this current, and the intensity of the light is proportional to the current flowing through the LED.

The emitted light passes through a transparent insulation material and is detected by a photodiode or phototransistor on the output side of the optocoupler. The photodiode or phototransistor is positioned so that it is in the path of the emitted light.

When the light falls on the photodiode or phototransistor, it causes an electrical current to flow through the output circuit. The amount of current flowing through the output circuit is proportional to the intensity of the light.

The output circuit can then use this current to control a load, such as a motor or a relay. The load is connected to the output circuit through a load resistor, which limits the amount of current flowing through the load.

The optocoupler provides electrical isolation between the input and output circuits, which prevents any direct electrical connection between them. This isolation can help to reduce noise and interference, and also provides a level of protection against voltage spikes and other electrical disturbances.

The Fig 11 shows the circuit diagram of optocoupler and the Fig 12 shows the module of optocoupler.

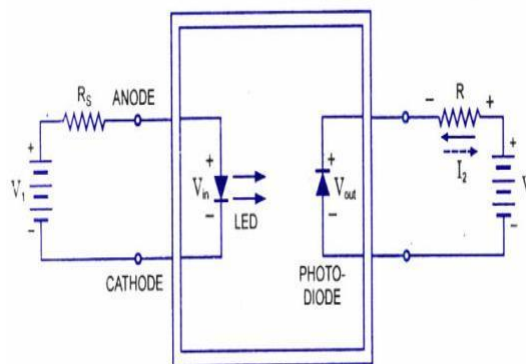

Fig 11 Optocoupler



Fig 12 Optocoupler

### 6) CURRENT SENSOR

The ACS712 is a current sensor module that can be used to measure both AC and DC currents. The module is based on the Hall Effect, which is a principle that describes the behaviour of magnetic fields on a current-carrying conductor. The Hall Effect is used to measure the magnetic field created by the current, which in turn can be used to determine the current flowing through the conductor. The Fig 13 shows the pin diagram and model of the current module.

The ACS712 module contains a Hall Effect sensor, which is sensitive to magnetic fields created by the current flowing through a nearby conductor. The sensor produces an output voltage proportional to the magnetic field, which is then amplified and filtered by the onboard amplifier and filter circuitry. The resulting output voltage is then proportional to the current flowing through the conductor.

To use the ACS712 module, the current-carrying conductor is passed through the centre hole of the module, and the output voltage is read using an analog input of a microcontroller.

The output voltage is proportional to the current flowing through the conductor, and the actual current can be calculated using the sensitivity and scaling factors.

The current sensor is used to measure the current from the overload and send it to Arduino ATmega328 microcontroller.

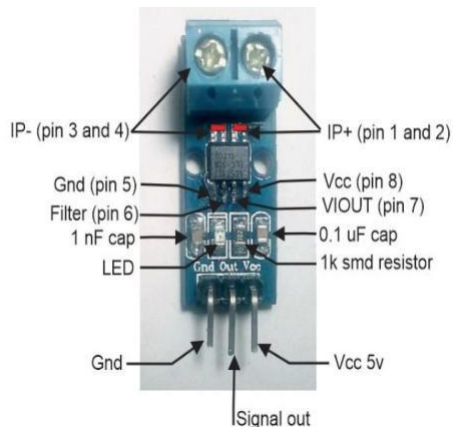

Fig 13 Current

### sensor 7) 100-watt BULB

A 100-watt bulb works by converting electrical energy into heat and light energy. When an electric current passes through the bulb's filament, the filament heats up and begins to glow, producing light. However, not all of the electrical energy is converted into light. A significant portion of it is converted into heat, which is why incandescent bulbs are not very efficient.

The filament inside the bulb is made of a resistive material, typically tungsten. As the electric current passes through the filament, it encounters resistance, which causes the filament to heat up. The filament is designed to operate at a high temperature, typically around 2500 degrees Celsius, which causes it to emit visible light.

However, as mentioned earlier, a large amount of the electrical energy is also converted into heat, which is why incandescent bulbs are not very efficient. Only about 10% of the energy consumed by a 100-watt bulb is converted into visible light, with the remaining 90% being converted into heat.

The 100watts bulb is used here for the overload has it observe more current than 0.5watts bulb. The below Fig 14 shows the model of 100w bulb.



Fig 14 100w Bulb

### 8) 0.5-watt BULB

A 0.5-watt bulb is a low-power LED bulb designed to consume minimal energy while producing light. The bulb uses an LED (light-emitting diode) as its light source, which is a semiconductor device that converts electrical energy into light energy.

The LED bulb contains a small semiconductor chip that emits light when an electric current is passed through it. The chip is housed in a small plastic casing with electrical contacts that allow it to be connected to a power source.

The LED bulb typically uses a DC (direct current) power source, such as a battery or a power supply, which is connected to the electrical contacts of the bulb. The power source supplies a low voltage and low current to the bulb, which is enough to activate the LED chip and produce light. In this system three 0.5watt bulb is used for each phase of the AC supply and denote that the system is in normal condition. The Fig 15 shows the model of the 0.5w bulb



Fig 15 0.5w Bulb

### 9) BLUETOOTH MODULE

Bluetooth technology is a wireless communication protocol that allows devices to communicate with each other over short distances, typically up to 10 meters. It uses radio waves in the 2.4 GHz band to transmit data between devices.

When two Bluetooth-enabled devices want to communicate with each other, they first need to be paired. Pairing involves establishing a secure connection between the two devices by exchanging a secret key. This key is used to

encrypt data sent between the devices, ensuring that the communication is secure.

Once the devices are paired, they can communicate with each other by forming a wireless link. The link is established using a process called inquiry, where one device sends out a signal to discover nearby Bluetooth devices. The other device responds with its unique Bluetooth address, and the two devices can then connect.

Bluetooth technology supports a variety of profiles, which are sets of rules that define how different types of devices should communicate with each other. For example, there are profiles for sending audio between devices, profiles for exchanging files, and profiles for controlling remote devices.

Overall, Bluetooth technology provides a simple and convenient way for devices to communicate with each other wirelessly over short distances. It is widely used in mobile devices, such as smartphones and tablets, as well as in a variety of other consumer electronics products. The Fig 16 shows the Bluetooth module and pin diagram of Bluetooth module.

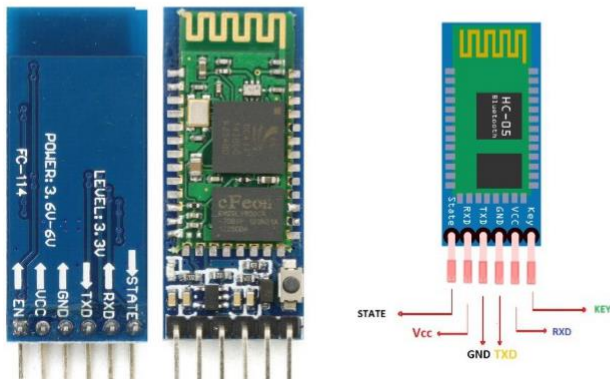

Fig 16 Bluetooth module

10 Hardware Result





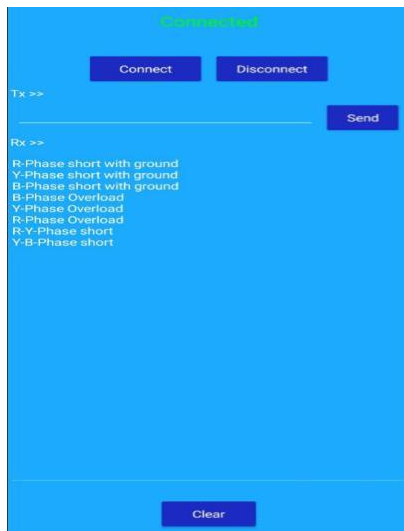

Fig 18 Hardware and Bluetooth result

The Fig.18 shows the working of a Three-phase fault analysis in overload, phase-to-phase, phase to ground conditions. In this way prevent equipment from being damaged and the type of fault is transmitted to the respected person.

## 11 Conclusion

Three-phase fault analysis with auto-reset on temporary faults and permanent trip otherwise is a reliable method for protecting electrical power systems. It involves detecting and analysing faults in the three-phase system and deciding whether the fault is temporary or permanent.

In case of a temporary fault, the system automatically resets after a predetermined time delay, allowing the fault to clear on its own. However, if the fault is permanent, the system triggers a permanent trip to isolate the affected section of the power system and prevent further damage.

Overall, this method provides an efficient and cost-effective way to protect electrical power systems, ensuring their reliable and safe operation.

## F. REFERENCES

- [1] IEEE Power System Relaying Committee; Automatic Reclosing of Transmission Lines; IEEE
- [2] Microcontroller based fault detection”, International Journal of Advancements in Research & Technology, Volume 1, Issue 5, October-2012 1 ISSN 2278-7763
- [3] Three Phase Auto Recloser Scheme; Nagar D Singh Bhalla D Paliwal D; IJSRD –International Journal for Scientific Research & Development; 2016 vol: 4 (01online) pp: 2321-613.
- [4] Three Phase Fault Analysis with Auto Reset for Temporary Fault and Trip for Permanent Fault; Bakanagari S Kumar A CheenyaM; Journal of Engineering Research and Applications

[5] Kimbark, Edward Wilson, ScD; Power System Stability; John Wiley & Sons, Inc., N.Y., London

[6] HAVRAN, F.J. 1999. Fault investigation on power transmission system. ESKOM. Internal document: 38, 96-99KELLER, P. 1998. Correct fault analysis. Eskom internal document

[7] Turan Gonen, “Electric Power Transmission System Engineering, Analysis and Design”, Crc Press Taylor and Francis Group.

[8] Paul M. Anderson, “Analysis of Faulted Power Systems”, The Institute of Electrical and Electronics Engineers, Inc., 1995.

[9] Miroslav D. Markovic, “Fault Analysis in Power Systems by Using the Fortescue Method”, TESLA Institute, 2009.

[10] Jun Zhu. “Analysis Of Transmission System Faults the Phase Domain”, Texas A&M University. Master Thesis, 2004.