



INVESTIGATING THE EFFECT OF STRENGTHENING CONCRETE STRUCTURES USING A CONCRETE JACKET SYSTEM

First author: Mehdi Aghaei^{1*}; Second author: Hossein Kazemi Fard²

^{an} *M.Sc. Department of Civil Engineering, Islamabad Gharb Branch Islamic Azad University, Iran*

^b *Assistant Professor, Department of Civil Engineering, Islamabad Gharb Branch Islamic Azad University, Iran*

Abstract

Concrete structures wear out due to factors such as earthquakes, strong winds, bearing loads, and fatigue, and they must be strengthened so that they are not damaged or destroyed. One of the best ways to strengthen a concrete building is to use a concrete coating or concrete jacket around structural elements such as columns, beams, and shear walls. Concrete coatings increase the shear and bending resistance of the column and make the column more ductile. The use of concrete coating depends on the conditions and can be implemented all around the column or in one part of the column. The most common use of concrete jackets is their use in strengthening shear walls and building foundations. In the method of strengthening the building with a concrete jacket, weak elements such as beams, columns, shear walls and even the foundation of the building will be strengthened by adding main bars and re-concreting. One of the most important and best advantages of reinforcement with concrete jackets is that this method requires completely homogeneous reinforcement; that is, at the end of the strengthening operation of an element in the building, the new element is also a concrete element. In this research, the strengthening of concrete elements by concrete jackets will be investigated.

Keywords: *concrete, strengthening, life span, concrete elements*

DOI: 10.48047/ecb/2023.12.si4.1082

Introduction

Today, structures have changed a lot compared to the past. It can be said that the use of new materials has changed the construction system in general. Many engineers are looking for a way to increase the load capacity as well as the safety of the structure, and then they use very specific ways (Van Nguyen, T., Le, H. T. T., & Nguyen, H. T. 2022; Bhardwaj M, et. al., 2022). It should be noted that many old structures or even new structures do not have optimal safety due to weak design and weak implementation and the need to strengthen the structure. Building retrofitting is very widely used today (Nabavi SS, et. al., 2022). Building retrofitting means improving the mechanism and operation of the structure (Aybo et al. 2022). In this case, the basic elements of the structure are strengthened. There are different methods for retrofitting a building, including retrofitting with FR fibers, planting rebar, retrofitting with a steel jacket, and retrofitting with a concrete jacket. One of the conventional methods of concrete buildings retrofitting is concrete jackets. In this method, weak elements such as beams, columns, shear walls, and even foundations are strengthened by adding main rebars and applying steel clips and molding, and re-concreting. Another advantage of the concrete jacket retrofitting method compared to other building retrofitting methods is the extent of its use in all parts of the structure. For example, foundation reinforcement cannot be done with a steel jacket; but the usually concrete jacket is used to strengthen shear walls. Shear walls play a very important role in determining the stiffness and increasing the strength of the structure and its stability against lateral loads. Because its dead weight is low, its use in concrete structures and their design is very important.

Methodology

The research method is the use of numerical and analytical models. The method is the most practical method to achieve the characteristics of reinforced members with concrete jackets and can be used by most engineers. In this research, a numerical and analytical model has been presented to predict the behavior of members reinforced with concrete jackets at both member and structure levels.

Background

Yamada investigated the effect of shear span,

axial force balance, and life reinforcements on the behavior of concrete columns. The aforementioned study showed that increasing the axial force or the ratio of the shear opening or reducing the life reinforcements causes a sharp decrease in the plasticity of concrete columns.

Elzanati et al. investigated the effect of longitudinal tensile reinforcements on the behavior of reinforced concrete beams. In this study, they concluded that by increasing the percentage of longitudinal reinforcement in beams without transverse reinforcement, its shear capacity also increases; but this increase is less than the increase in the bending capacity of the test samples.

In order to investigate the sensitivity of confining pressure on the compressive strength and deformation capacity of concrete, Cetisli and Naito conducted laboratory studies on concrete samples under variable confining pressure. Their study included constant, linear-elastic, elastic, plastic, and bilinear confining stress levels due to transverse reinforcements. They found that the stress-strain diagram of the confined concrete is dependent on the changes in the applied confinement pressure and the assumption of confinement with constant pressure is not suitable.

Wong et al also confirmed the effect of ductility on the behavior of concrete columns by conducting similar experiments. In order to consider the effect of ductility, Priestley et al presented a model in which shear strength is a function of displacement ductility.

Factors creating the necessity of retrofitting in concrete structures

Earthquake force

Due to the fact that Iran is located in an earthquake-prone region and also the possibility of not correctly recognizing the earthquake force in the design of many structures that were done in the past, a large number of structures need seismic strengthening. Structures reinforcement in dealing with vibrations and forces caused by earthquakes with different methods is one of the relatively new topics in scientific circles.

Design errors

Design errors include a lack of proper understanding of the soil and foundations of the area, lack of attention to the principles and basics of designing earthquake-resistant buildings, as well as mistakes in analysis and design, preparation of plans, documents, and executive

details of the structure.

Failure to comply with Implementation Rules

In case of an accurate and appropriate design of the structure, there is a possibility that the structure will not be implemented correctly and as calculated and designed. Such improper implementation can include many problems such as incorrect reinforcement, use of reinforcements with the wrong diameter and number, failure to observe the required length of restraints for longitudinal reinforcements, failure to properly implement connections, use of inappropriate materials, etc. in the implementation phase.

Changing the use of the structure

In many cases, there is a need to change the use of the structure (for example, from residential to educational or commercial) (Sadovnikova et al., 2022). In such a structure with a new use, even if the structure under investigation is designed correctly and all points related to earthquake load are taken into account, it may be subjected to new loads that were not foreseen in the previous use. Therefore, when changing the use of structures, it is possible to discuss their retrofitting.

Corrosion

Corrosions include steel corrosion as well as corrosion caused by carbonation, chlorine, acids, and sulfates in the concrete members of the structure. In a large part of Iran, especially in the south, the environmental conditions are highly corrosive, and in this regard, many structures will need to be strengthened.

Changes in loading regulations and their coefficients

Sometimes, with the passage of time and scientific developments, parts of the regulations and loading coefficients may change. Therefore, there is a need to review the design of the structures that were designed based on the older regulations, in accordance with the conditions of the new regulations. For this purpose, there may be a need to strengthen the mentioned structures.

Damage to structures caused by natural events such as wind, flood, etc.

Degradation of the performance level of

concrete structures over time and under the influence of environmental factors such as frost, melting, etc., is inevitable. Also, accidental loading such as wind and flood can cause serious damage to structures. In this regard, it is felt necessary to prepare and compile scientific and practical methods for repairing and strengthening such structures.

Objectives of seismic strengthening of structures

The following are among the most important goals of seismic strengthening in structures:

1. Ensuring the strength of the structure in order to prevent any damage (structural and non-structural) during mild earthquakes.
2. Ensuring the resistance of the structure against moderate earthquakes, without any structural damage (there is a possibility of some non-structural damage).
3. Ensuring the resistance of the structure against severe earthquakes that have already occurred in the place or are capable of occurring; So that the structure is not destroyed and the safety of the residents is maintained (in this case, there is a possibility of some structural and non-structural damages).

Types of failures of reinforced concrete columns

Reinforced concrete columns are one of the most important members resistant to horizontal and vertical loads in concrete structures; therefore strengthening the columns against earthquake forces can play an important role in strengthening the entire structure. Reinforcement of concrete columns is done in order to increase bending and shear strength. This is also done to increase the deformation capacity of the column near the connection to the beam and also to strengthen the weak connections. Damages caused by earthquakes in reinforced concrete columns can be in the form of shear, axial, bending failures, failures due to insufficient restraining length, and also failures due to buckling of longitudinal reinforcements. Shear brittle failure of concrete columns is the worst type of failure due to its sudden nature.

Modeling concrete beams and columns before strengthening

In the evaluation of the mentioned structural sections, a calculation procedure is needed to analyze the sections of the members and

determine the relationship of the bending Stress-strain diagram

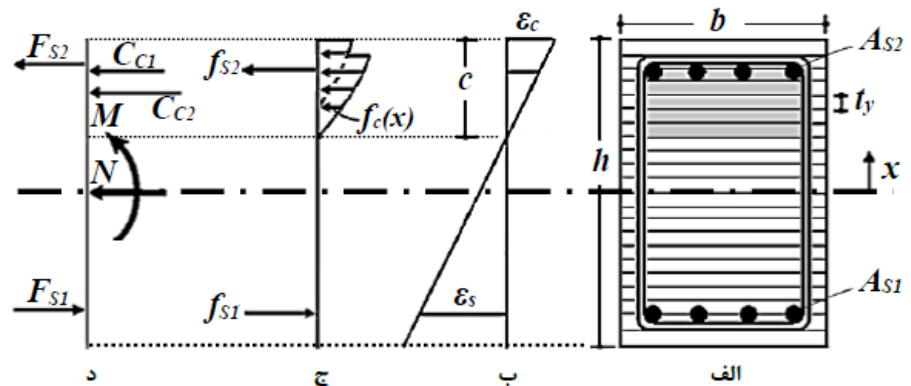

moment and then convert this relationship into the moment relationship. Before performing such an analysis, the stress-strain characteristics of the materials must be determined. In this research, a fully elastoplastic model is considered for the stress-strain diagram of the longitudinal and transverse reinforcements with respect to the re-hardening of the steel. The figure below shows the stress-strain diagram of the steel used in this research.

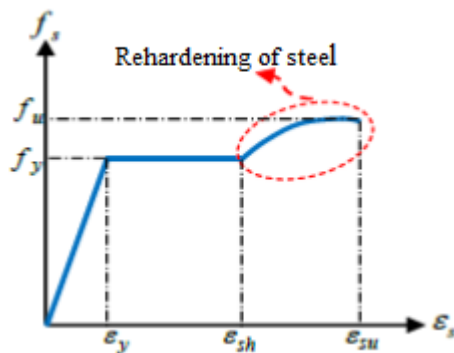

Bending behavior

When the stress-strain relationship of concrete in different areas is determined, the relationship of the curvature of the member is obtained based on the elemental analysis of the section of strip elements. The figure below shows the elemental analysis of the cross-section of the reinforced concrete member schematically. C_{c1} and C_{c2} are the compressive force of the contribution of concrete covering and concrete enclosed by the cross-sectional reinforcement, respectively. Other variables are described in the figure.

Elemental analysis of reinforced concrete member cross-section. A- Section B- Distribution of strains C- Distribution of stresses D- Distribution of compressive and tensile forces

Shear behavior

Insufficient shear capacity of beams and columns in concrete structures can lead the behavior of the members toward the brittle shear failure mechanism. Also, due to the occurrence of shear cracks in the members and the reduction of the axial capacity of the section, it may cause axial failure in the members under the axial force and increase the vulnerability of the structure against earthquakes (Sezen et al., 2002). Also, the increase in bending deformations through the creation of tensile diagonal cracks along the length of the member can lead to shear or

bending shear failures in case of improper design. Therefore, it seems necessary to consider the effects of the shear mechanism as a function of bending deformations in the nonlinear analysis of reinforced concrete members and structures.

Modeling concrete beams and columns strengthened by the concrete jacket

The non-linear behavior of a concrete member can be determined and evaluated through the analysis of the curvature anchor and subsequently converting it into a rotating anchor. Therefore, in

order to perform such an analysis on the reinforced concrete member, defining the properties of its materials is prioritized.

Diagram of strain stress of sections

strengthened by the concrete jacket

The figure below shows a section of a member that is subjected to confinement pressure from internal and external transverse reinforcements.

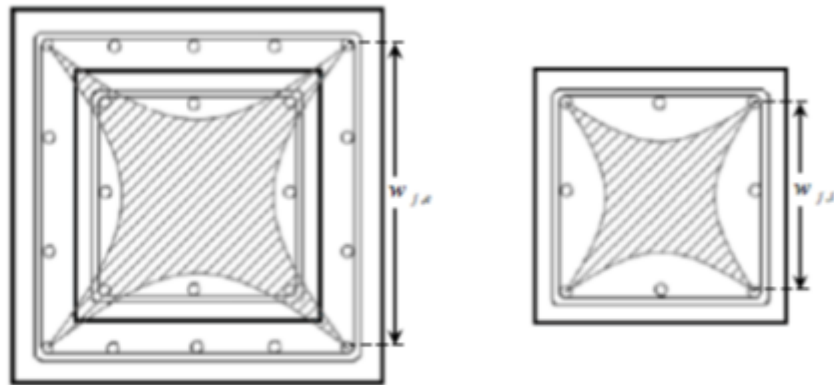

B- Reinforced section by concrete jacket A- The primary section

Areas enclosed by a- internal transverse reinforcements and b- external transverse reinforcements reinforcements.

In the current research, the concrete in the section of the reinforced member with the concrete jacket system can be divided into the following 4 areas:

1. Concrete coating in the new layer;
2. The area enclosed by external transverse reinforcements;
3. Covering the old section enclosed by external transverse reinforcements;
4. The core of the old section is surrounded by internal and external transverse

The bending and shearing behavior of the member was strengthened by the concrete jacket

In order to model the bending behavior of the strengthened member, the implementation of the said strengthening system is very important. In the case of continuous implementation of the concrete jacket, it can be expected that the concrete jacket system will bear tensile and compressive force.

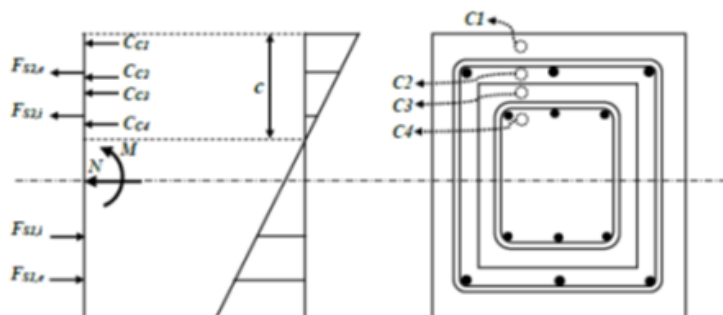

Distribution of forces Distribution of strains Reinforced section by concrete jacket

Force balance in a sample section strengthened by the concrete jacket

Final conditions

In the present study, the final conditions in the analysis of the rotating anchor are defined based on the occurrence of one of the following criteria.

- The strain of concrete in the enclosed

areas is more than the compressive strain of the final concrete;

- The tensile strain in the longitudinal reinforcement is greater than the final strain of the steel;
- In case of bending failure, there is a 20% decrease in the bending capacity of members (Figure below):

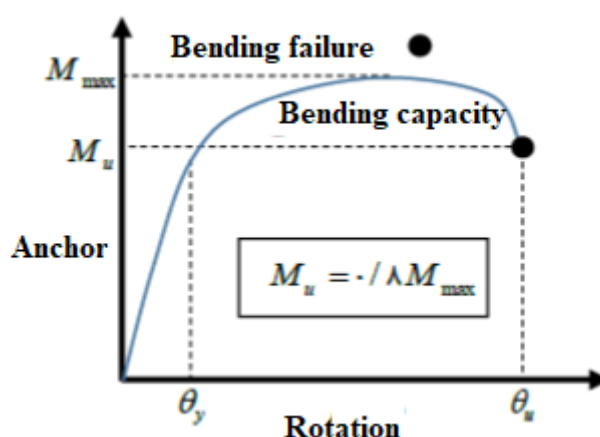

20% reduction in bending capacity in bending failure

Parametric studies

In this study, a parametric study was carried out in order to investigate the effect of concrete jacket thickness on reinforcing reinforced concrete columns. The specifications of the

investigated columns can be seen in the figure below. The compressive strength of old and new concrete and the yield strength of longitudinal and transverse reinforcements are considered to be 20 and 420 MPa, respectively. Also, the columns have one end and one free end, with a free length of 1200 mm, and the axial force acting on it is considered equal.

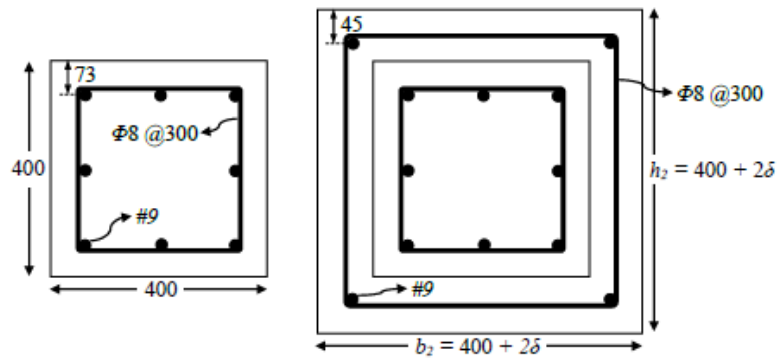

Geometric specifications and longitudinal and transverse reinforcements in the parametrically studied columns

In the figure below, the effects of changes in the thickness of the concrete jacket on the bending behavior of the said column were investigated. As can be seen in this figure, with the increase in the thickness of the initial hardness concrete jacket, the bending strength corresponding to the yield range of the longitudinal

reinforcements and the maximum bending strength of the reinforced column increases; one of the reasons for that is the increase in the anchor arm of tension and compression bars. Also, according to this figure, the final deformation decreases with the increase in the thickness of the concrete jacket, while the plasticity coefficient of displacement has a direct relationship with the increase in the thickness of the concrete jacket.

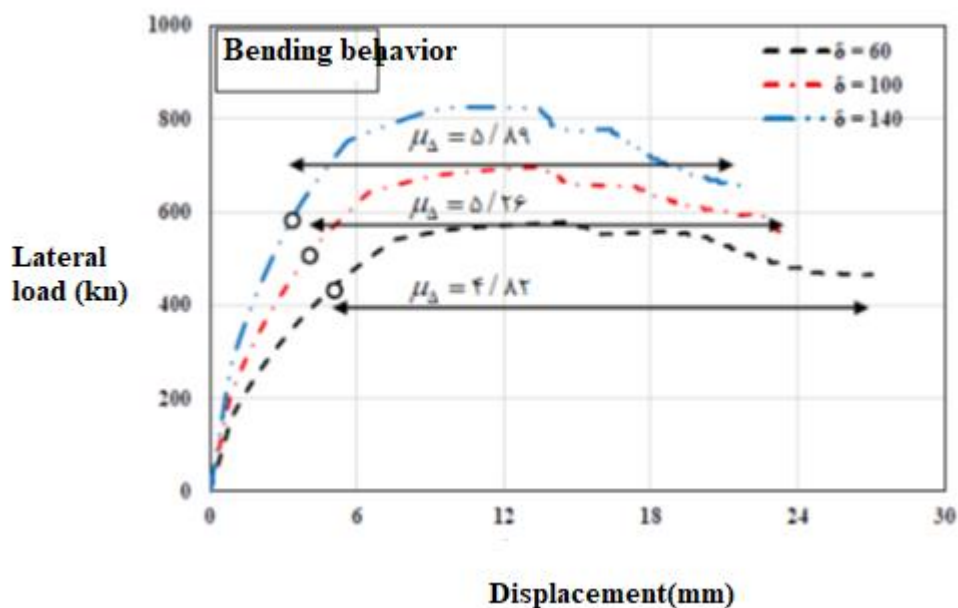

Effect of concrete jacket thickness on flexural behavior

compared with the laboratory results.

Validation

In this section, to evaluate the accuracy of the proposed model for reinforced concrete members reinforced with a concrete jacket, the results of the nonlinear analysis were compared using the proposed model with the results reported from experiments conducted by other researchers (ersavi et al. 1993). First, for each sample, we examine the proposed model in terms of resistance, so that the interaction diagrams of the axial force of the bending anchor obtained from the analytical model are

Vandoros and Dritsos (Vandoros et al., 2008) conducted a laboratory study on reinforced concrete jacket columns under reciprocating loading. The figure below compares the interaction diagram of the axial force of the bending anchor of the columns reinforced by the concrete jacket with the points obtained from the laboratory data. As can be seen, there is a close convergence between the results obtained from the experiment and the analytical model. Therefore, it is obvious that the presented model can successfully predict the response of reinforced columns with concrete jackets.

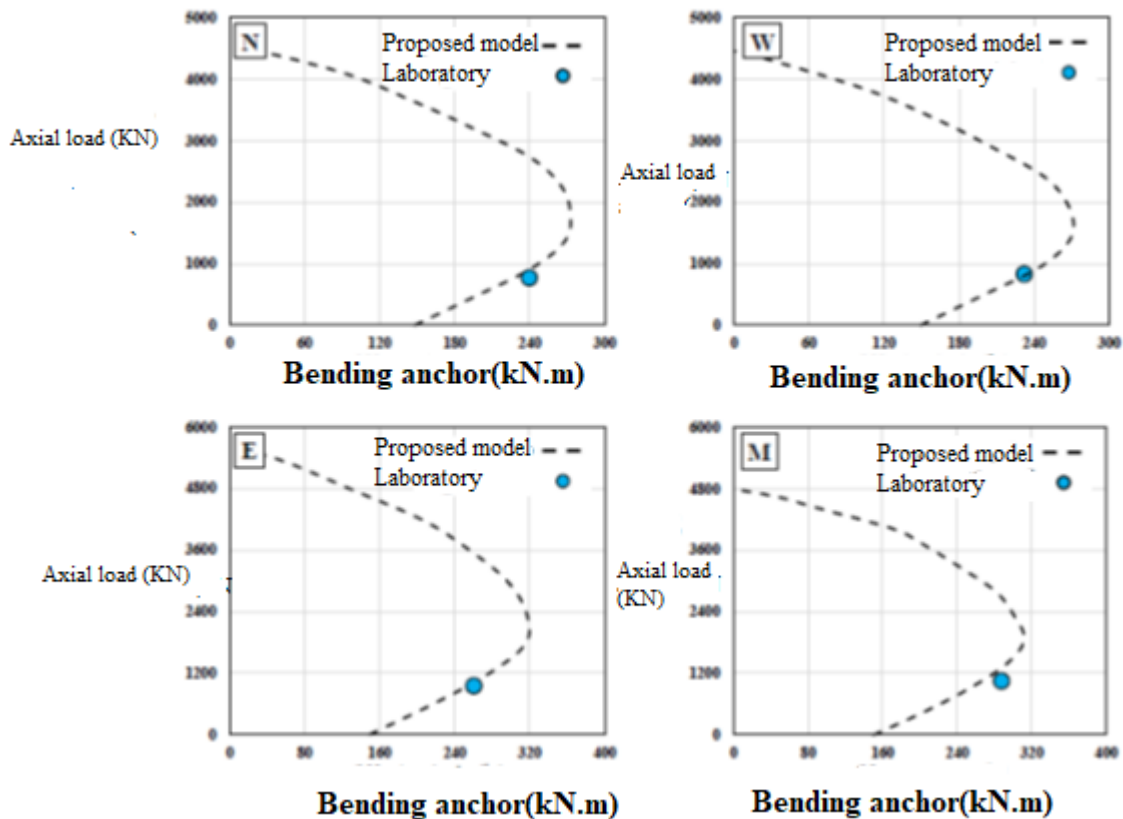

Axial bending moment force interaction diagram of columns tested by Vandoros et al

Ersoy et al. (1993) conducted experiments to investigate the behavior of columns strengthened by concrete jackets under the combination of axial load and bending anchor. In the figure below, the interaction diagram of the axial force of the bending anchor of reinforced concrete

jacket columns was compared with the points obtained from the laboratory data. The results show that the analytical model can well predict the maximum resistance of reinforced columns under the combination of axial load and bending moment.

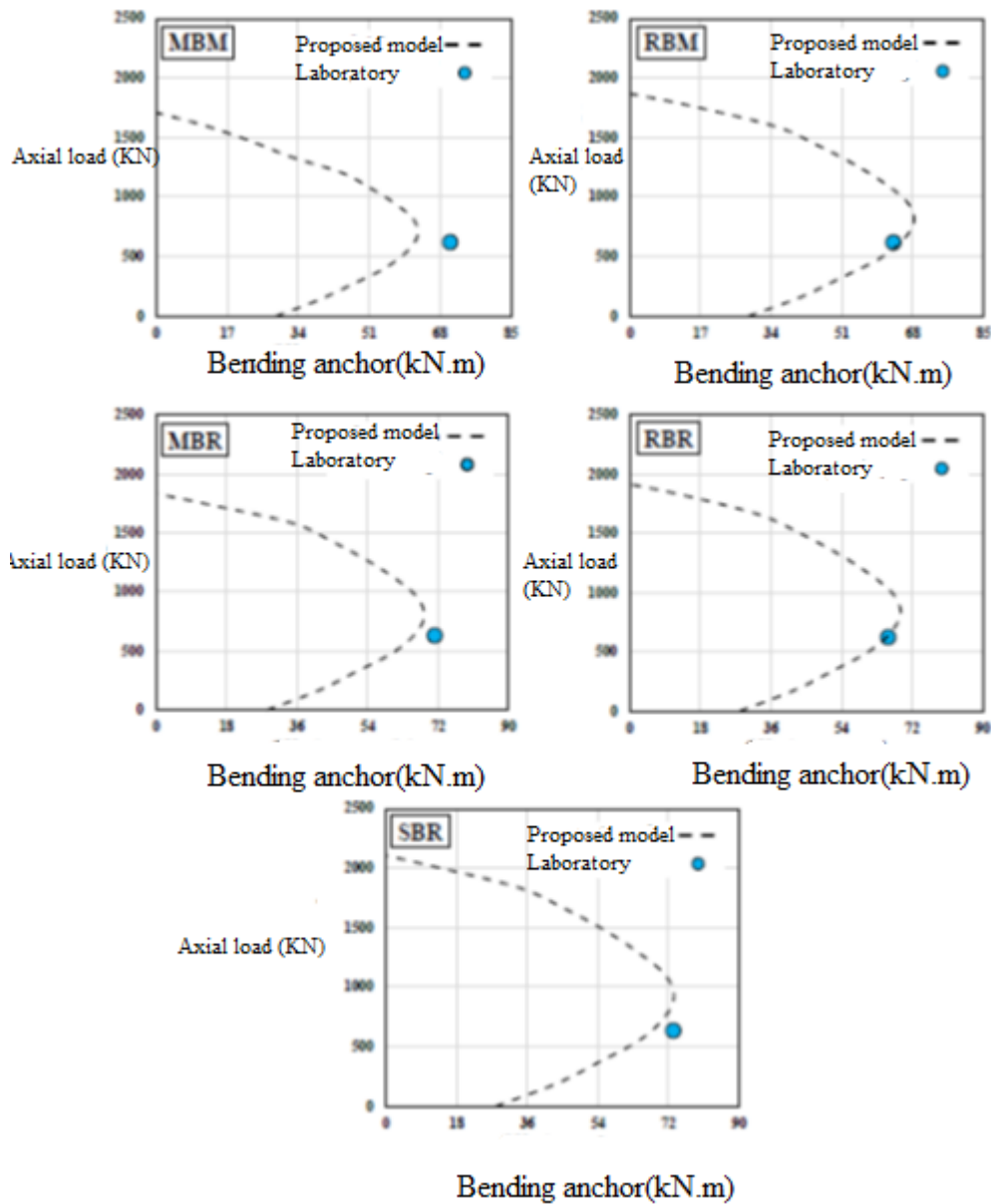

Interaction diagram of the axial force of the bending anchor of the columns tested by Ersoy et al

To further investigate the capability of the proposed model in predicting the maximum strength of columns reinforced by concrete jackets, the samples tested by Bousias et al. (Trang, 2007) were simulated. In the figure below, the interaction diagram of the axial force

of the bending anchor obtained by the analytical model is compared with the experimental results. Again, the maximum strength of reinforced concrete jacketed columns has been successfully predicted. This shows that the assumptions considered to determine the non-linear behavior of reinforced concrete jacket columns in this study are reliable.

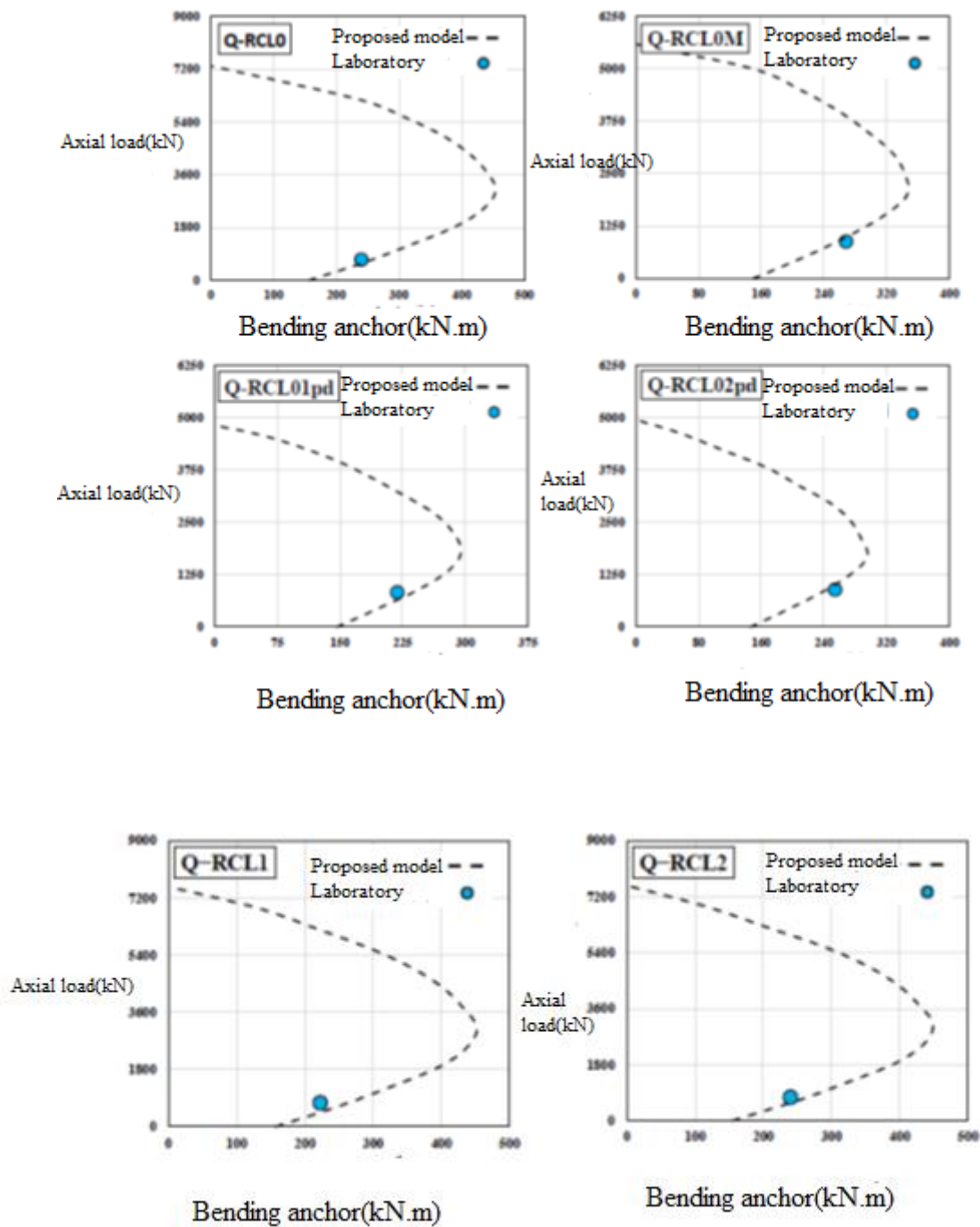

Interaction diagram of the axial force of the bending anchor of the columns tested by Trang

In the following, the response obtained from the analytical model in terms of strength and ductility was compared with the laboratory results. In the figure below, the relationship between the curvature anchors of the sample tested by Ersoy et al. was compared with the

results obtained from the proposed analytical model. As can be seen, the proposed model for predicting the results of the bending moment analysis in terms of bending capacity and initial stiffness is in good agreement with the laboratory results.

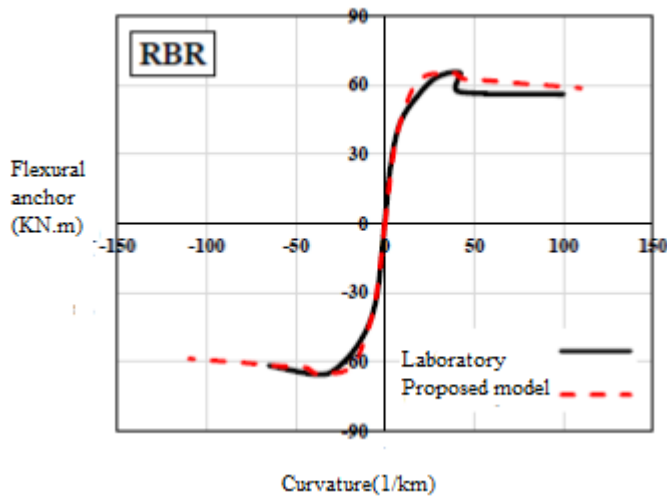

Comparing the laboratory results reported by Ersoy et al. with the relation of the curvature anchor obtained from the proposed model

In the figure below, the lateral load-displacement relationships reported by Bousias et al. (2004) and Vandoros are compared with the results obtained from the nonlinear analysis using the proposed model. As can be seen in the figure, for Q-RCL1 and Q-RCL2 samples, the proposed model predicts the maximum resistance is relatively high; but it is accurate in

predicting the ductility and initial hardness of the samples. Also, considering that the final displacement in sample N was obtained non-conservatively, the maximum initial strength and hardness are well predicted by the proposed model. In general, according to the simulated samples, it can be said that the proposed model predicts the laboratory results in terms of resistance, ductility, and initial hardness in an acceptable manner.

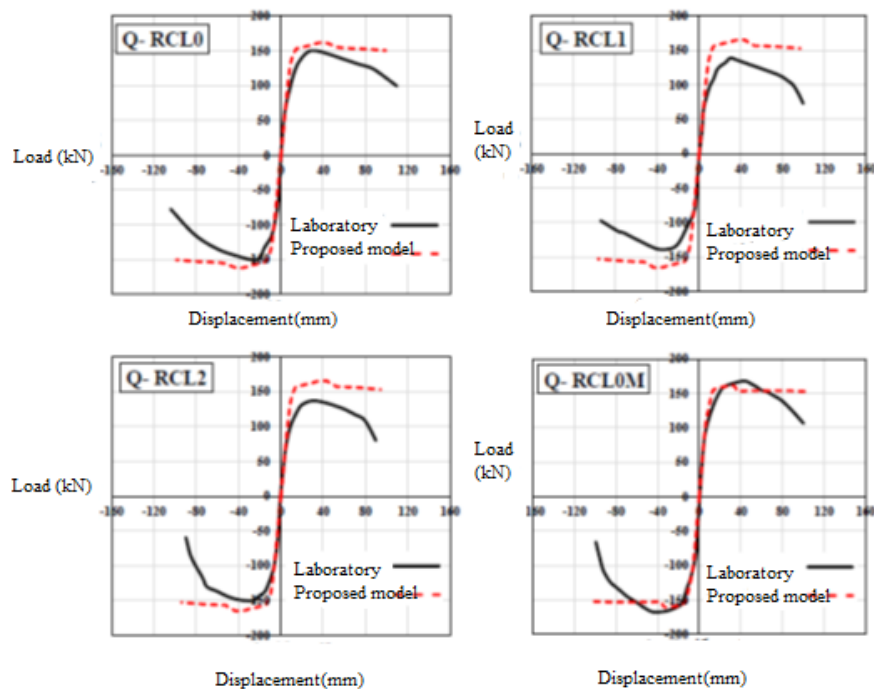

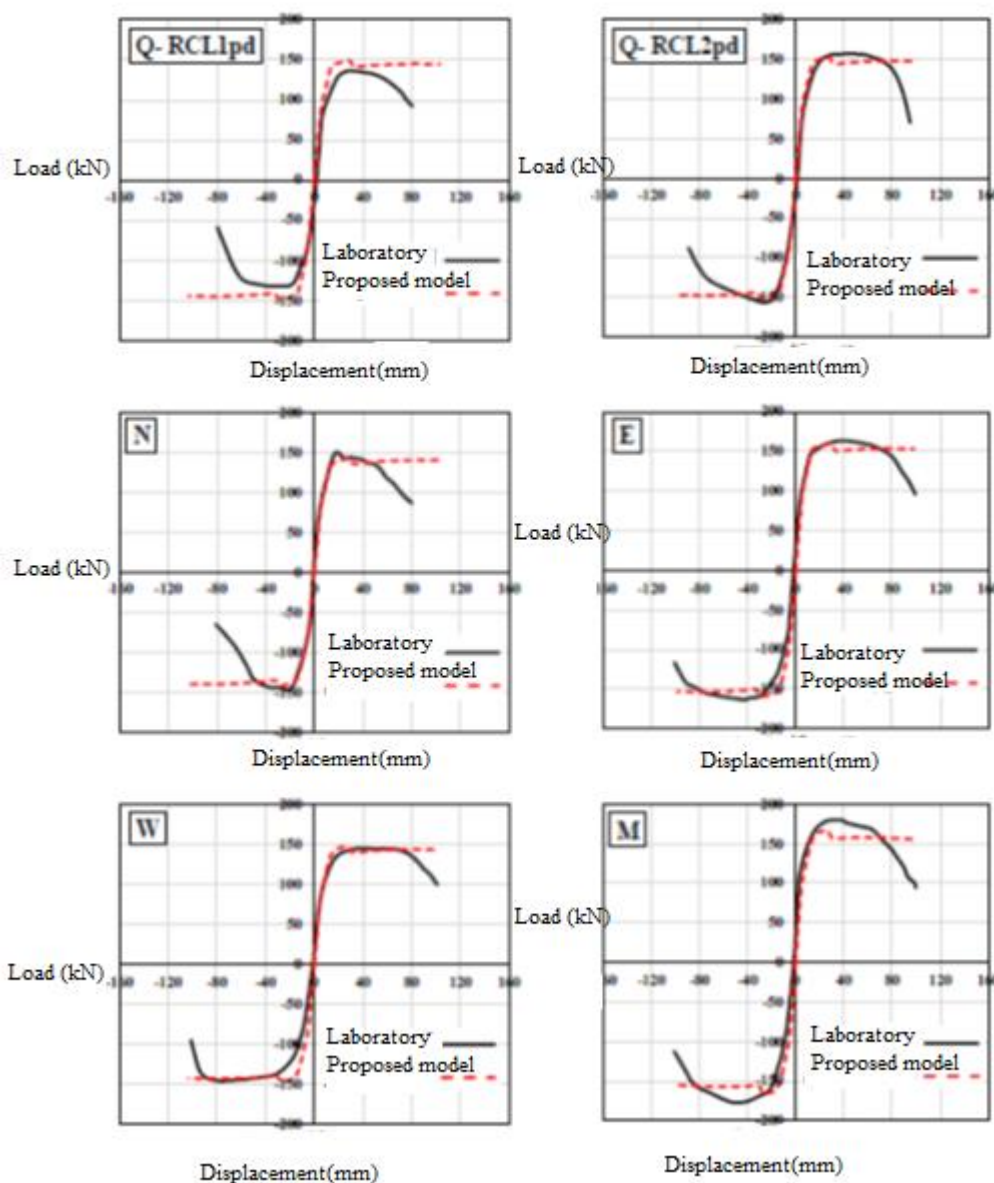

Comparing the laboratory results reported by Bousias and Vandross with the load-displacement relation obtained from the proposed model

Conclusion

Many structures suffer damage, weakness, and subsequent loss of resistance due to various reasons, including the increase in the lifespan of the structure, weaknesses in design and implementation, natural accidents, the effect of chemical factors, etc. The lack of resistance of the structure and its implementation make the building's operation and performance difficult. In such a situation, due to the high cost of replacing the structure, it is necessary to compensate for the lost weaknesses by

implementing strategies aimed at strengthening the building. Despite the high seismicity in most of the populated parts of the country and the vulnerability of the existing buildings against earthquakes, learning, training, and research in the field of methods of repair and restoration, improvement, and strengthening of structures is of special importance. Since the mechanisms of failure and reduction of the useful life of structures are mainly the result of a: design mistakes b: implementation mistakes and defects, a correct system should be established for the application of guidelines and standard regulations and control in monitoring good execution in constructions. Considering that the useful life of

structures depends on several factors, including the quality of materials, quality of execution, and environmental conditions, it is necessary to benefit from modern and advanced methods, so that in addition to preventing the destruction of structures, securing and improving their capacity and useful life. The results of recent studies and research show that integrated methods that include a combination of retrofitting methods can be more responsive to technical needs and in practice have obtained better results.

As a type of reinforced concrete, ferrocement has a good efficiency in the repair and restoration of both steel and concrete structures, especially in corrosive marine environments, and its use is recommended. The method of cutting columns and building a new foundation using the jacking system and separators is a suitable method for buildings that are historically, culturally, etc. important.

References

- Bousias, Stathis, Alexis-Loukas Spathis, and Michael N. Fardis. "Seismic retrofitting of columns with lap-splices via RC jackets." (2004).
- Cetisli, Fatih, and Clay J. Naito. "Concrete subjected to varying confinement, I: Experimental evaluation." *Journal of Advanced Concrete Technology* 7, NO. 2 (2009).
- Elzanaty, Ashraf H., Arthur H. Nilson, and Floyd O. Slate. "Shear capacity of reinforced concrete beams using high-strength concrete." In *Journal Proceedings*, vol. 83, NO. 2 (1986).
- Ersoy, Ugur, A. Tugrul Tankut, and Ramadan Suleiman. "Behavior of jacketed columns." *Structural Journal* 90, NO. 3 (1993).
- Rodriguez, Mario, and Robert Park. "Seismic load tests on reinforced concrete columns strengthened by jacketing." *Structural Journal* 91, NO. 2 (1994).
- Sezen, H. and Moehle, J. P. "Seismic behavior of shear-critical reinforced concrete building columns." *Seventh US national conference on earthquake engineering*. Boston: Earthquake Engineering Research Institute, MA. (2002).
- Thermou, G. E., S. J. Pantazopoulou, and A. S. Elnashai. "Flexural behavior of brittle RC members rehabilitated with concrete jacketing." *Journal of Structural Engineering* 133, NO. 10 (2007).
- Vandoros, Konstantinos G., and Stephanos E. Dritsos. "Concrete jacket construction detail effectiveness when strengthening RC columns." *Construction and Building Materials* 22, NO. 3 (2008).
- Wong, Yuk-Lung, Thomas Paulay, and MJ Nigel Priestley. "Response of circular reinforced concrete columns to multi-directional seismic attack." *Structural Journal* 90, NO. 2 (1993).
- Yamada, M. "Shear strength, deformation and the explosion of reinforced concrete short columns." *Special Publication* 42 (1974).
- Elzanaty, Ashraf H., Arthur H. Nilson, and Floyd O. Slate. "Shear capacity of reinforced concrete beams using high-strength concrete." In *Journal Proceedings*, vol. 83, NO. 2 (1986).
- Wong, Yuk-Lung, Thomas Paulay, and MJ Nigel Priestley. "Response of circular reinforced concrete columns to multi-directional seismic attack." *Structural Journal* 90, NO. 2 (1993).
- Priestley, MJ Nigel, Ravindra Verma, and Yan Xiao. "Seismic shear strength of reinforced concrete columns." *Journal of structural engineering* 120, NO. 8 (1994).
- Sadovnikova, N., Lebedinskaya, O., Bezrukov, A., & Davletshina, L. (2022). The correlation between residential property prices and urban quality indicators. *Journal of Advanced Pharmacy Education & Research*, 12(2), 98-103.
- Oran, İ. B., Ayboğa, M. H., Erol, M., & Yildiz, G. (2022). The Necessity of Transition from Industry 4.0 To Industry 5.0: SWOT Analysis of Turkey's SCM Strategy. *Journal of Organizational Behavior Research*, 7(2), 1-17.
- Nguyen, T. V., Le, H. T. T., & Nguyen, H. T. (2022). Evaluating the curriculum of vocational schools in Vietnam. *Journal of Advanced Pharmacy Education and Research*, 12(2), 57-62.
- Nabavi, S. S., & Gholizadeh, B. (2022). Evaluation of the Quality of Life of the Patients with Heart Failure in Ahvaz Teaching Hospitals. *Entomology and Applied Science Letters*, 9(1), 26-30
- Bhardwaj, M., Kapila, R., Neha, A., Jain, R., Mittal, P., & Suri, M. (2022). Awareness, Perceived Risk, and Protective Behavior Towards Covid-19 Among Undergraduate Students of Delhi and NCR, India. *International Journal of Pharmaceutical Research and Allied Sciences*, 11(3), 71-80.