



## DESIGN AND FABRICATION OF IOT VOICE CONTROLLED IGNITION SYSTEM

JOSIA VARGHEESE THOMAS<sup>1</sup> , SITA SAI ANIRUDH<sup>2</sup>

1 Student, IV/IV Mechatronics , Dept of mechanical engineering, MGIT ,Hyderabad

2 Student, IV/IV Mechatronics , Dept of mechanical engineering, MGIT ,Hyderabad

---

### ABSTRACT:

By employing vocal commands, vocal Control enables the operation of in-vehicle technology. With the aid of this technology, drivers may use a number of in-car features conveniently while driving and without taking their eyes off the road. The usability of traditional voice interfaces is greatly enhanced by Voice Control with natural language understanding technology. With the use of cutting-edge voice recognition technology, it gauges the user's purpose from ambiguous words and operates in-vehicle machinery. Users of this interface can control the device without expressing commands or names clearly, enabling efficient and precise equipment operation while driving.

The ability to start the car is one of the primary purposes of a vehicle key, along with access to the vehicle and the ignition system. By substituting the key with a specific user's voice, a speech-based engine access control system may take the role of these key operations. In the suggested system, access might be granted just by an enrolled user speaking into a system-attached microphone. Following that, the suggested method will determine whether the word is "On" or "Off." The decision voice will be transmitted to Arduino in order to turn on the car relay, which will turn on the starter motor for the engine. This project's primary goal is to create and build a voice-activated car ignition. By using a voice command, the user can activate the system and start the vehicle. As a result, this system functions as a digital key

---

## 1. INTRODUCTION:

One of the most crucial systems used in I.C engines is the ignition system. The compressed air-fuel mixture needs to be ignited by a mechanism in a spark-ignition engine. The ignition system accomplishes this by igniting the fuel inside the cylinder at the conclusion of the compression stroke. A current plug is reached by it, which is a component of the electrical system. It provides the spark needed to properly ignite the air-fuel mixture. The igniting system delivered current spikes at high voltages (up to 30,000 volts) to a spark plug. At the spark plug gap, these surges cause the electric sparks. The compressed air-fuel mixture in the combustion chamber is ignited by a spark. Every cycle of operation must have the proper timing for the sparking to occur at the conclusion of the compression stroke. The spark is advanced at high speeds or when operating at part throttle. The mixture has time to burn and produce power since it happens a little sooner in the cycle. The engine should run smoothly at both high and low speeds thanks to the ignition system. It must to be lightweight, small, and easy to maintain. It shouldn't interfere in any way.

### 1.1 Components of Ignition System

**Battery** :The battery is utilised to supply the ignition system with current. The ignition coil is then powered by this. The battery typically has a voltage of 6V or 12V.

**Ignition Switch**: The engine can be started or stopped with it. The Primary Winding of the Ignition Coil is connected to one end of the switch, while the Battery is attached to the other end.

**Ignition Coil** : It is the primary component of the ignition system. Its primary function is to increase battery voltage to a level where it may generate a spark. It functions as a step-up transformer and has two windings: a primary winding with a smaller turn and a secondary winding with a larger turn.

**Distributor**:Used in a multi-cylinder engine, its function is to regulate the spark in each spark plug in the proper sequence according to the firing order.

**Spark Plug:** The spark plug is another important part of the ignition system. This is where the actual spark is generated for the combustion of fuel or charge. If there is more than one spark plug, each is connected separately to the distributor and emits the spark in sequence.

### **Function of the ignition system**

- Generating a high-voltage electrical spark in the combustion chamber at the proper time to burn the air-fuel mixture.
- This creates a potential difference of ~25 kV at the spark plugs.
- It supplies high ignition voltage to each spark plug in the correct sequence.
- It adjusts the ignition timing to the speed and load of the vehicle.
- The ignition spark is adjusted to be generated when the piston is near top dead centre.

## **2. LITERATURE REVIEW**

**Prof. Bhuvaneshwari Jolad, Mohnish Arora, Rohan Ganu, and Chetan Bhatia. (2018).**

The main purpose of this project is to control the movement of the vehicle using voice commands. The command is sent using an Android application connected to the robotic vehicle through a Bluetooth module. This system contains a transmitter that converts analogue voice commands into digital word sequences. The receiver MAX 232 transceiver is used to decode the received signal for serial communication with the Bluetooth module.

**Hans Tiwari and Ashish Jha. (2019)**

This project consists of an autonomous vehicle controlled by specific voice commands defined for a specific action. Alexa will be used to transmit voice commands to the car. The robotic car will be able to move according to the commands given by the user, such as turn left, turn right, move forward, move backward, stop.

**R. Veeramani, R. Madhanmohan, Deepak Prajapati, Aman Kumar, and Sidharth Kumar. (2019)**

The main objective of this proposed system is to develop a robotic car that can be controlled by human voice, speech or commands and perform certain actions. This project aims to reduce the parking problem and also be used in the defence sector.

**Arti Paswan, Ajay Kumar Gautam, Bhartendu Vimal, Farheen and Arun Kumar Mishra. (2019)**

This project developed a prototype robotic car that can be controlled by the human voice. The prototype was developed using two technologies, human-computer interaction (HCI) and human-robot interaction (HRI). The project also includes the use of IOT and wireless camera.

**P R Bhole, N L Lokhande, Manoj L Patel, V D Rathod, and P R Mahajan. (2017)**

The main objective of this project is to develop a robotic car that works with human voice to reduce human effort in driving. The proposed system also elaborates the use of AI sensors.

**Shashanki Singh, Sumedha Tode, Rekha Takalkar, Prof. Dr. S. R. Patil**

They have implemented the system to control applications like window motor, seat motor, windshield wiper etc. They also use an Arduino to measure the fuel level with a level sensor and all these applications are automatically controlled by voice.

**M Saravanan developed an “Arduino-based voice-controlled robotic vehicle” (October 2020)**

The main goal of this device is to develop a robotic vehicle that can be controlled by a person's voice. These systems are commonly referred to as voice-controlled automation systems (SCAS). The above device is a prototype of our design. The concept is to build a robot that is controlled by voice commands. A cell phone is used to operate the robot; there are several articles demonstrating contact between a robot and a smartphone. For remote automation of the robot, a smartphone is an excellent interface. It has a variety of useful functions. In this design, the given task is

performed using an Android application and a microcontroller. Bluetooth technology facilitates communication between the software and the robot. The module receives the commands sent through the channel. The goal of a voice controlled robotic vehicle (VCRV) is to listen and respond to the user's commands.

#### **H. Jagadish Kumar wrote “Voice Controlled Car using Arduino and Bluetooth Module” (December 2019).**

The goal of this report is to build a voice controlled car that responds to voice commands. However, improvements in the areas of interference and range handling are needed. Simple voice commands such as "left," "right," "forward," "back," and "stop" are used to navigate the vehicle. These signals are sent from an Android application to the Bluetooth module. A Bluetooth module and a control device are used to record and analyse the voice input. In this proposed method, different control configurations for robots have been studied. It shows that real manuscripts can be effectively explored and replicated by using only speech (human voice) as a means of control

### **3. PROBLEM EXPLANATION**

Keys have evolved greatly in the last century. A car is vulnerable if someone has access to the keys. Keys do not provide a high level of security. Most cars do not require the use of a traditional key.

#### **i. Loss of connection with the engine control unit (ECU)**

One of the most common problems with car keys is loss of connection with the ECU. When you insert your key into the ignition switch, it normally sends a unique code to the ECU. The system recognizes this code and allows you to start the car. Unfortunately, problems can occur with this system. In such cases, the system does not recognize the unique code. This in turn results in the car not starting.

#### **ii. Incorrect placement of the key**

This case occurs when you place your key in the car and then lock it. Usually, it can be in the trunk or on the driver's seat. This problem gets worse if you have an extra

key. But that one is then also in the glove compartment. So you can't access both keys and have difficulty opening your car.

iii) Loss of the key

In this case, the key is not damaged or defective. Rather, the key is untraceable. Usually, this can happen in a number of ways. For example, it may be that you have misplaced the key. Or that someone has stolen it. Regardless of the circumstances, this is a problem. As a rule, you will not be able to find your way to the car. And even if you find it, you will not be able to start the car.

iv. Damage to the key

There is no doubt that car keys are durable. For example, they don't break off or bend easily. However, that doesn't mean they are immune to damage. Yes, a car key can sometimes get damaged. This is especially the case if you do not take the minimum amount of care.

#### **4. METHODOLOGY**

In this proposed system, no voice recognition module is required to recognize the human voice to start/stop the vehicle. In this system, apple home is used to send the voice commands to the ESP 8266 12E Module through ESP01 soft api.. The aim of this paper is to develop a PCB to control the ignition systems for cars by human speech using wireless communication system. With the advancement of technology, things are becoming easier and easier for us. This system uses electrical subsystems reliable and cost effective.

The commands that can be given to control the igniton are:

start/turn on my car : to turn on the vehicle

stop/turn off the ignition:to turn off the vehicle

#### **Why voice command ?**

The main purpose of our project is to perform certain actions using voice commands, where the driver gives a certain voice command and the car performs the

corresponding action. So we are building a user friendly key so, the voice recognition will be the best method to control the vehicle.

The main goal of our project is to develop a user-friendly smartphone key that can be controlled by voice commands given by the driver. The voice command is processed using a cell phone and the human voice,. The command is sent through the WIFI router ESP01 in the car using. This ESP01 forwards the command to ESP8266 12 E and this module checks the command and acts accordingly.

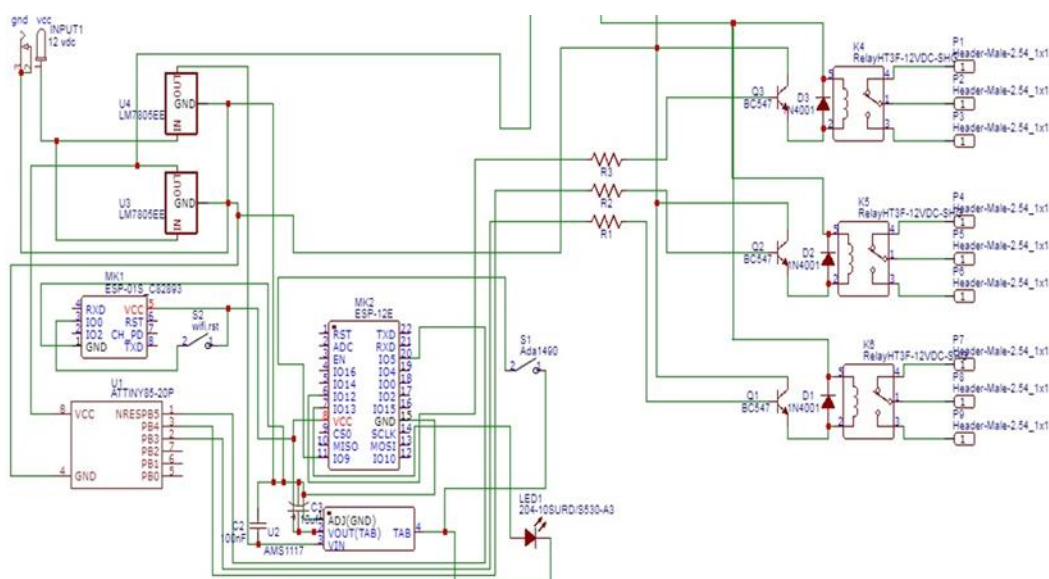

The 12 V from the car battery is fed to the LM7805 (voltage regulator), which then lowers the supply voltage to 5 V and passes it to the ASM1117. The ASM1117 lowers the voltage to 3.3 V and supplies that ESP8266 12 E WIFI module. This WIFI module supplies 3.3 V to various other components that are connected to it.

we have an ESP01 module that acts as a router and creates a path for user commands to ESP8266. When we connect to ESP01, we can transmit data to ESP8266 12E WIFI module.

After receiving the data to ESP8266 12E WIFI module, the AT tiny 85 will be switched ON based on the data, resulting in a very small time delay.

There 12V and 5V relay connected to the circuit where 12V relay always remains ON, the 5V relay is only turned on for 0.08 seconds and those 0.08 seconds are clocked by the ATtiny85 module.

When the power supply is guaranteed, a current flows through the BC547 transistor and the car is turned on ON.

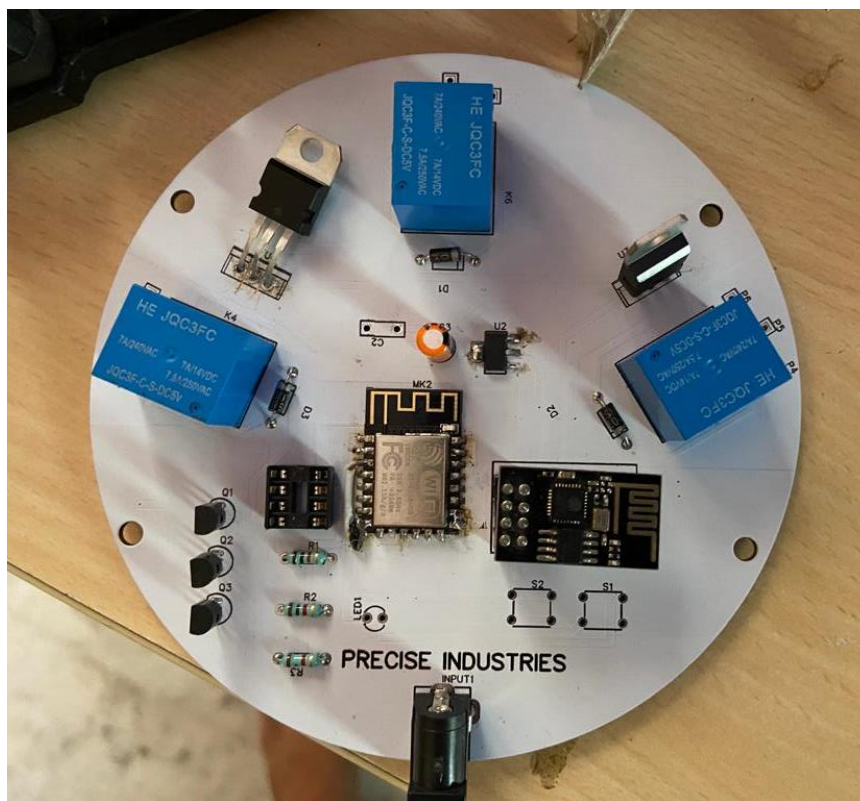

working model PCB

## 5. COMPONENTS

The following are the components:

1. Esp 01
2. Esp-12e Esp8266 Wifi Module
3. Lm7805 (5v Stepdown)
4. Relay 5v and 12v
5. Ams1117 (3v Stepdown)
6. Capacitor
7. Resistor
8. Bc547 Transistor:
9. At Tiny 85



**5.1 ESP -01:**

This is a Wi-Fi module that creates a path for transferring data from the smartphone to components in the PCB. ESP 01 can be encrypted. This makes the transmission of commands secure. The ESP -01 WIFI Wireless Transceiver Module is a standalone SOC with an integrated TCP/IP protocol stack that gives any microcontroller access to your Wi-Fi network.

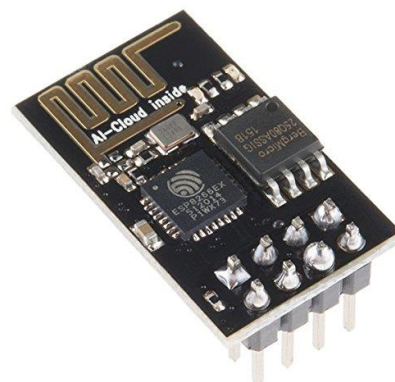

The ESP -01 can be controlled over your local Wi-Fi network or the Internet (after port forwarding). The ESP -01 module has GPIO pins that can be programmed to turn on a LED or a relay ON /OFF over the internet. The module can be programmed with an Arduino/USB to TTL converter via the serial pins (RX, TX).

**5.2 ESP -8266 12E:**

Esp-12E Esp8266 Wifi module is a low power consumption of UART-WIFI module and ultra-low power consumption technology, designed specifically for mobile devices and IoT applications, user physical device can be connected to a WIFI wireless network, Internet or intranet communication and network capabilities. The module supports the standard IEEE802.11 b/g/n agreement and the complete TCP/IP protocol stack. Users can add the module to an existing network device or build a separate network controller.



ESP8266 is a low-cost and high-performance wireless module SOC, which offers endless possibilities for integrating WIFI functions into other systems. It can control inputs and outputs like Arduino, but the special feature is that it comes with Wi-Fi.

Compared to other Wi-Fi solutions on the market, ESP is the best option for most "Internet of Things" projects! Since it is so cheap that it costs only a few dollars, it

can also be integrated into advanced projects. And ESP is also compatible with Arduino IDE.

ESP-12E is a member of the "ESP-XX" series. It is a miniature Wi-Fi module designed to provide a wireless network connection for a microcontroller or processor. The core of ESP -12E is ESP8266EX. This module has no complicated circuitry or programming, so using this module is very simple.

ESP8266 is a highly integrated wireless SOC designed for mobile platform developers with limited space and power requirements. It offers the unmatched ability to embed Wi-Fi capabilities into other systems or function as a standalone application at the lowest cost and with minimal space requirements.

### 5.3 LM7805 (5V STEPDOWN):

A regulated power supply is an essential component of many electronic devices and circuits. Semiconductor material is used in these power supplies, which has a fixed current and voltage value. The IC 7805 is part of the 78XX series of linear voltage regulators that produce a regulated 5V output, since most TTL ICs use 5V logic and therefore we need a consistent 5V power supply. The IC 7805 is therefore useful for



this purpose.

The 7805 IC is a three-terminal voltage regulator that has a fixed 5V output and can be used in a variety of applications. The main features of the IC are as follows:

- It delivers a current of up to 1.5A with the heat sink.
- It operates with a current of 5mA.
- It operates with only a few components.
- It also has thermal shutdown and internal current limiting functions.

The 7805 is a three-terminal linear voltage regulator IC with a fixed output voltage of 5V, useful for a variety of applications. As mentioned earlier, the 7805 is a three-terminal device, the three pins being:

1. INPUT
2. GROUND and
3. OUTPUT.

The LM7805 is a voltage regulator that outputs +5 volts.

#### 5.4 RELAY 5V AND 12V:

A relay is a simple electromechanical switch. While we use normal switches to manually close or open a circuit, a relay is also a switch that connects or disconnects two circuits. However, instead of a manual operation, a relay uses an electrical signal to control an electromagnet, which in turn connects or disconnects another circuit.



Relays are typically used in control panels, manufacturing, and building automation to control power and switch smaller values of current in a control circuit.

A 5V relay is an automatic switch commonly used in an automatic control circuit to control a high current with a low current signal. The input voltage of the relay signal ranges from 0 to 5 V.

12V Relay:

A 12V relay is an automatic switch commonly used in an automatic control circuit to control a high current with a low current signal. The input voltage of the relay signal ranges from 0 to 12 V.

**5.5 AMS1117 (3V STEPDOWN):**

The AMS1117 is a series of low-dropout voltage regulators capable of delivering up to 0.8 A of output current. The AMS1117 is available with six fixed voltages: 1.2, 1.5, 1.8, 2.5, 3.3 and 5.0 V. In addition, it is also available in an adjustable version. On-chip precision trimming sets the reference/output voltage with  $\pm 2\%$  accuracy. On-chip thermal limiting provides protection against any combination of overload and ambient temperatures that would cause excessive junction temperatures.



The AMS1117 series is available in SOT -223, TO252 and SOT89 packages. A minimum 10uF tantalum capacitor is required at the output to improve transient response and stability.

**5.6 BC547 TRANSISTOR:**

The BC547 transistor is an NPN transistor. A transistor is nothing but a resistive transmission used to amplify current. A small current at the base terminal of this transistor controls the large current at the emitter and base terminals.

The main function of this transistor is amplification and switching. The maximum gain current of this transistor is 800 A.

This transistor operates at a fixed voltage DC in the preferred range of its characteristics, which is called the bias voltage. In addition, the series of this transistor can be divided into three groups based on the current gain: BC547A,

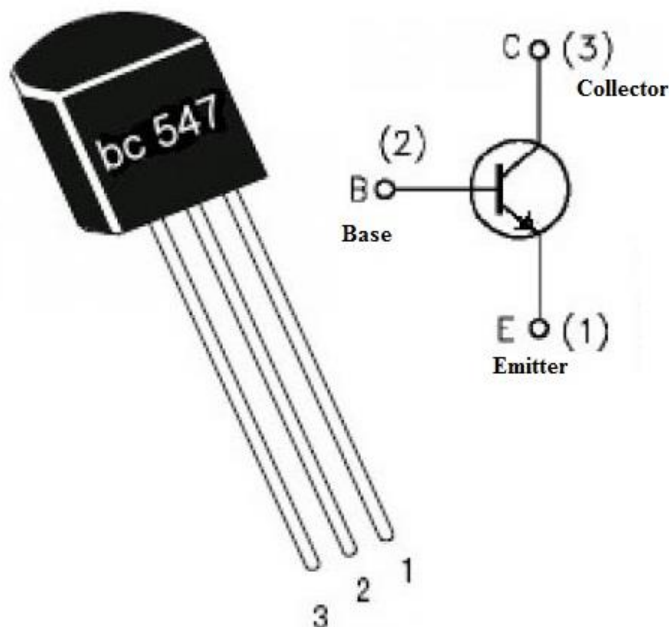

BC547B and BC547C.

The BC547 transistor has three pins, which include the following:

- Pin1 (collector): This pin is marked with the symbol "C", and current flows through the collector terminal.
- Pin2 (Base): This pin controls the bias voltage of the transistor.
- Pin3 (Emitter): The current flows through the emitter terminal

A transistor works as an amplifier while amplifying voltage, current, and power in various configurations in the active region. The amplifier circuit uses three configurations, including the following.

- Amplifier with common emitter (CE)
- Amplifier with common collector (CC)
- Amplifier with common base (CB)

## 6. RESULT

The proposed system is basically a IOT voice-controlled vehicle key that helps to control the car through voice commands received through an smart phone. This is

controlled by voice commands from the user operating the mobile phone. These voice commands must be given through smart phone with the help of the voice assistant or smart device interfaced applications installed by the user. Voice recognition is done in the smart phone, and then a corresponding command is sent to the PCB.

Commands: There are 2 commands that can be used to control basic actions of the vehicle:

Start the vehicle/ Turn on the vehicle: To start the ignition of the vehicle

Turn ignition off/ Turn car off: To turn off the ignition of the vehicle

## 7 CONCLUSION

This project was conducted to provide more safety for the cars by providing voice controlled ignition. In this project, The ignition is controlled by voice commands. The voice commands are transmitted to the Google Assistant/Siri through a microphone present in the smart phone..These commands are sent to the ESP8266 12E through the path created by the ESP01 router module and acts accordingly.All the components are integrated on a single PCB to achieve compactness and good performance. This study has achieved the goals set at the beginning of the evaluation and is attractive because it is convenient and ergonomic to the user. Although the developed prototype still has limitations and shortcomings, but these limitations can be modified in the future for other applications such as unlocking the vehicle and accessing the luxuries in the vehicle such as air conditioner , music controller etc.

## 8 REFERENCES

- H. Jagadish Kumar et.al wrote “Voice Controlled Car using Arduino and Bluetooth Module” (December 2019).
- Controlling a robot using Android Interface and Voice by Kishan Raj KC, (2012).
- M Saravanan et.al developed “Arduino Based Voice Controlled Robot Vehicle” (October 2020).
- Parichart Leechor et.al wrote “Operation of a Radio- Controlled Car by Voice Commands” (March 2010).

- Vipul Mehta et.al gave “Robot Controlled Car Using Wi-Fi Module” (May 2016).
- Mrumal. K. Pathak et. al wrote “Robot Control Design Using Android Smartphone” (February 2015).
- Shubh Srivastava et.al contributed “Voice controlled robot car using Arduino” (May 2020).