



IoT based Real Time Street Lights controlling on Motion Detection

Dr. Nookala Venu

Assistant Professor, Internet of Things (IoT), Offered by Department of IT,
Madhav Institute of Technology & Science, Gwalior - 474 005, Madhya Pradesh, India,
(A Govt. Aided UGC Autonomous Institute).

venunookala@mitsgwalior.in

Article History:

Received: 22.07.2023

Revised: 02.08.2023

Accepted: 03.09.2023

Abstract:

A Street light is raised source of light on the edge of a road or walkway, which is turned ON at ascertain time every night. The System consists of LED, PIR sensor, IR Sensor and LDR sensors which are connected and controlled using Raspberry pi. Three modes of Operation is going to be done in this project by giving commands. PIR Sensor will be placed before certain number of street lights which detect the moving vehicles by automatically turning ON Whole Street lights for a period of time declared. LDR sensor is fixed, which activates during night by turning on the Lights and remain off during day time. An IR sensor is fixed for every street light pole to detect the motion by automatically turning ON the respective Street Light. This is intended with Solar Module which is controlled by Arduino Uno. Here solar power is used as power supply for street lights.

Keywords: *Raspberry Pi, street light, sensors, energy saving.*

DOI: 10.48047/ecb/2023.12.9.143

1. Introduction

Street Automation plays a very important role in the world economy and in daily life. Automatic systems are being preferred over any kind of manual system. Intelligent light sensing refers to public street lighting that adapts to movement by pedestrians, cyclists and cars. This street lighting System referred as adaptive street lighting, dims when no movement is detected, but brightens when motion is detected [1-2]. This type of lighting is different from traditional and illumination or dimmable street lighting that dims at pre-determined times. Embedded means something that is connected to another thing and a system is an arrangement in which all its unit fabricate work together according to a set of rules. It can also be described as a way of working, organizing or doing one or many tasks according to a fixed plan. An embedded system can be thought as a computer hardware system having

software embedded in it. An embedded system is a microcontroller or microprocessor based system which is designed to perform a specific task. The Internet of Things has developed due to the convergence of multiple technologies, real-time analytics, commodity sensors, machine learning, and embedded systems. Traditional fields of embedded systems, wireless sensor networks, control systems, automation and others all contribute to enabling the Internet of Things [3-4]. The growth of Internet of Things (IoT) has brought about a revolution in our day to day lives. Cheaper and improved sensor technology has provided an impetus to this revolution of IoT. Each and everything can be connected to the internet and synchronized to interact, collaborate and contribute [5-6]. IoT has been responsible for machine-human inter-dependency. The major advantages that IoT offers include improved efficiency, reduced interaction time and human effort. It also provides support to Artificial Intelligence and Data Mining due to the involvement of larger data-sets and the need for extracting useful information in order to improve efficiency to the application and add 'Smartness' to it. IoT has a great potential for Automation and Data research [7-8]. The thing that we are considering in this paper is a Street Light. The main motivation of this research work is derived from the fact that lighting accounts for more than 15 percent of electricity consumption of the world. This also contributes about 1.6 billion tons of carbon emissions (per year) in the atmosphere [9-14]. With the aim to cut-short the energy wastage through the conventional street lighting systems and realizing the growing demand of Automation, it is important to work in this area for making the Street Light smart, we need to define smartness. A 'Thing' is said to be 'Smart' if it is able to sense its immediate surroundings and perform actions that work towards a desired goal [15-20]. If we fit the Smart Street Light to this definition, we can describe the system as composed to things called Street Lights equipped with sensors, illustrated in figure 1, to sense ambient light, motion, temperature, humidity, faults and moving objects, acquire data through the sensors, apply some pre-processing algorithms to compress data, and send it to the Cloud via an IoT gateway [21-28]. From the Cloud which consists of a better Infrastructure and storage and Analytical capabilities, users can retrieve beneficial information including visibility in foggy days, ambient light, temperature and humidity in sunny days, traffic density, etc. and researchers can fetch useful data and analyze those data for further research that includes temperature and humidity characteristics of a particular location, season, etc.

The IoT allows objects to be sensed and controlled remotely across existing network infrastructure, creating possibilities for more direct integration of the physical world into computer-based systems, and resulting in improved efficiency and accuracy [29-34].

2. Literature Review

Street Lightning System is necessary to provide ease to the people for safety measurements on the road during nights. Many authors have worked on this street lightning system [35-39]. It suggested an intelligent management of the lamp posts by sending data to a central station by ZigBee wireless communication. With the suggested system, maintenance can be easily and efficiently planned from the central station, allowing additional savings. Many researchers have proposed a number of methodologies and ideas to reduce the energy wastage of the street lights and also highlighted the ways to make them smarter [40-47]. An innovative literature review in the field of saving energy with the help of electro-technology as well as Information and Communication Technology (ICT) in Street Lights. The state of Smart Street light which consists of monitoring and executive programming [48-53]. The information exchange between lamp nodes and wireless sensor networks (WSN) can be a feasible since it is composed of three parts: Control center, Remote concentrator and Street lighting control terminals. Smart Street Lighting system can be integrated with VANET to reduce the cost and use the rich service and communication feature of VANET [54-61]. An adaptive street lighting control based on energy demand idea and showed that the conventional street lighting regulation system he tested showed that adaptive control provides on an average almost double energy saving. There was an ease of maintenance and high communication rate among the devices in the system [62-67]. A Smart Street Lighting (SSL) system is proposed for switching off the street lights based on the desired level of safety and location of pedestrians. The proposed system consisted of Zigbee enabled motes, a Base Station, a centralized SSL Server, server applications for system configurations and Web-Application for monitoring and controlling the lighting zones and lampposts and smart phones of pedestrians with GPS functionality [68-71]. A street lighting system based on ZigBee has also been proposed. The monitoring of the connected sensors for fault detection, power adjustment and on/off control is done via Zigbee wireless technology. The proposed system gathers the parameters of street light via GPRS and Zigbee communication. It includes three main components: a terminal for street monitoring, concentrator and monitoring centre. The concentrator acts as a repeater and works as a bridge between monitoring center and control terminals [72-75]. Its main task is to forward command and data. The task of the control terminal is to fetch the data and make the required adjustments in the power. An autonomous-distributed-controlled light system was proposed in which lights get turned on before a pedestrian actual arrives at that location and then gets off after a pedestrian leaves a certain location. The proposed system comprised brightness sensor node,

LED lamps, motion sensor and communication network based on short distance [76-78]. There are access points which consist of the controller and the communication device. An Automatic Intensity Varying Smart Street Lighting System is presented in which the initial step was to replace the existing lampposts by LED lights in order to reduce the energy dissipation as LED lights are more energy efficient. Secondly, Light Dependent Resistor (LDR) has been deployed in order to control the lights automatically without any human intervention. In order to control the luminosity of the lights, dimmers are installed. A novel street lighting system is proposed which uses the renewable energy source i.e. solar energy. The luminosity of the street lights is controlled based on the intensity of sunlight which is sensed by LDR [79-80]. In case of low intensity of solar energy, the resistance value of LDR is high and based on this value it is decided that whether the street lights should be on/off. In case of moderate value of resistance, the dimming function of lights is invoked. PIR sensor is also utilized to detect the motion of the pedestrian. A novel fuzzy logic based controller is presented whose main objective is to minimize the wastage of power in street light 4 Sahil Garg, Sahil Ahuja and Sukhchandani Randhawa systems. Solar energy is utilized in order to save electric power. A fuzzy rule base is designed which takes natural intensity and occurrence of vehicles as inputs based on the rule set defined by fuzzy logic. A hybrid street lighting system based on Vehicular Ad-Hoc Networks and traditional street lighting system is proposed. VANET provides various functionalities such as reporting the location, direction, speed of vehicles in real time scenario. Road-Side Units (RSUs) are deployed usually 300-400 m apart. The main task of these RSUs is to report the data to the light controllers to switch on and off a light. A reliable on-demand street lighting model is proposed in which the concept of traffic flow rate forecasting model is utilized. There are number of methods based on 1-h prediction whose results are compared with the model based on ANN which reports the best results [81-82]. As per the above discussed literature, it is clearly concluded that most of the ideas are based on motion detection of a person or a vehicle on a road.

3. Objective

The main objective of this Street Lightning System is to control energy efficient LED street lights to turn ON only when needed otherwise to remain OFF. It helps to decrease the wastage of Electricity by controlling the working of street light system.

4. Overview of Proposed Scheme

PIR Sensor, LDR Sensor and IR sensor are connected to the Raspberry Pi. There are three modes of Operation in this project by giving manual commands for every mode in putty software. The modes of operation are as follows.

Mode 1: If IR Sensor detects an object then the respective street light will turn on, if not it remains off. The process will continue till we exit from the command and then stop.

Mode 2: If PIR sensor detects the motion then the whole street lights will be turned ON for period of time declared. If PIR sensor does not detect any motion the street lights remain OFF. The process will continue till we exit from the command and then stop.

Mode 3: If LDR sensor module detects darkness i.e., in the night time the whole street lights will turn ON and in the daytime street lights will be turned OFF. The process will continue till we exit from the command.

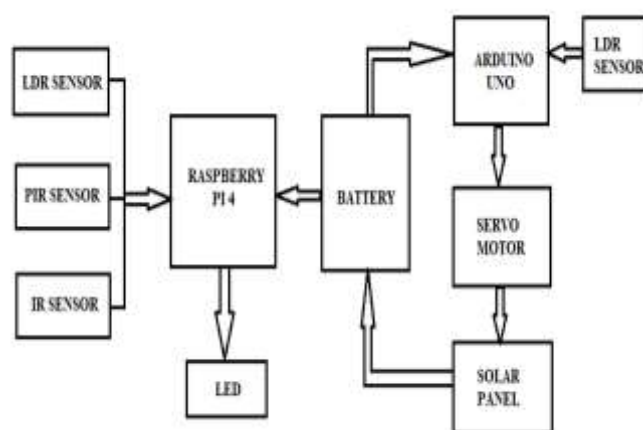

Fig.1: System Architecture

This is intended with Solar Module which is controlled by Arduino Uno. Solar panels are used for charging batteries by changing daylight into electricity. The energy which is stored in battery is used as power supply for the street lights. Thus, this technique reduces power wastage and also a manual switch is provided. Servo Motors are used in applications to control rotational speed and position as well as output torque. Servo Motor is connected to Arduino Uno to control the direction of solar panel.

4.1 Hardware Requirements

Raspberry Pi 4: Raspberry Pi is a small-sized computer used Linux operating system. It is a small size computer used to run larger and smart programs to achieve output quickly. RPi 4 B+(RP4) is the latest model developed by the company, which has all the essential latest wired and wireless communication system used in most of the smart projects. A single

Raspberry Pi 4 comes to a Quad-core Processor but it has three various versions which give three various sizes of RAM.



Fig.2: Raspberry Pi 4

Infrared Sensors: An IR sensor is an electronic device that is used to sense some aspects of the surrounding environment. An IR sensor can measure the heat of an object as well as detects the movement as well as the presence of an object due to interruption. These type of sensors measure only infrared radiation, rather than emitting it that is called as a passive infrared sensor, an IR sensor is simply a device which detects infrared radiation falling on it.

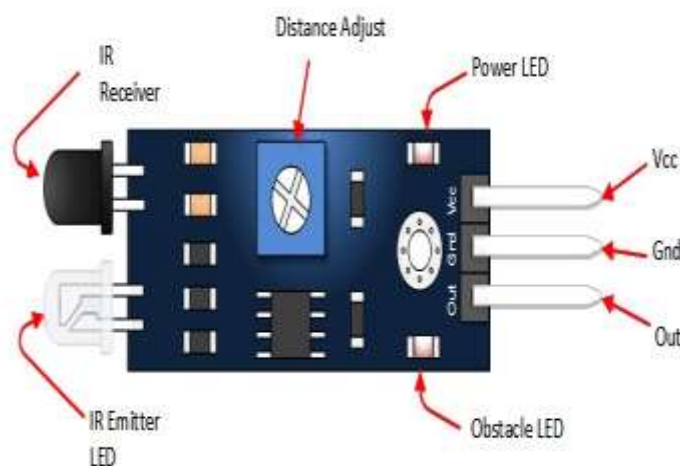

Fig.3: IR Sensor

Light Dependent Resistance: Light Dependent Resistors are very useful especially in light or dark sensor circuits. Light dependent resistor as the name suggests depends on light for the variation of resistance. Normally the resistance of an LDR is very high, sometimes as high as 1000000 ohms, but when they are illuminated with light resistance drops dramatically. Electronic onto sensors are the devices that alter their electrical characteristics, in the presence of visible or invisible light.

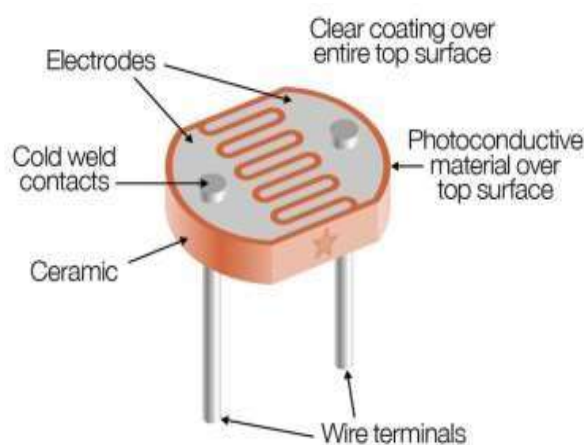

Fig.4: LDR Sensor

Passive Infrared Sensor: A passive Infrared Sensor (PIR sensor) is an electronic sensor that measures infrared (IR) light radiating from objects in its field of view. They are most often used in PIR based motion detectors. PIR sensors use a pair of piezoelectric sensors to detect heat energy in the surrounding environment. PIR sensors are commonly used in security alarms, motion detection alarms and automatic lighting applications.

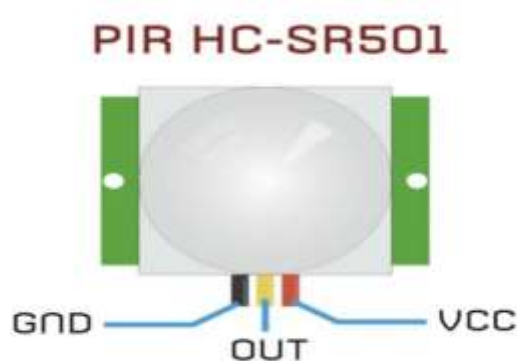

Fig.5: PIR Sensor

Arduino UNO: Arduino UNO is the microcontroller used in this paper, it is based on ATmega328. It is an open source electronic platform based on easy to use software and hardware. It reads input-light on sensor, finger on a button, etc. It has 14 input/output and 6 Analog pins. The software used in this microcontroller is Arduino IDE.

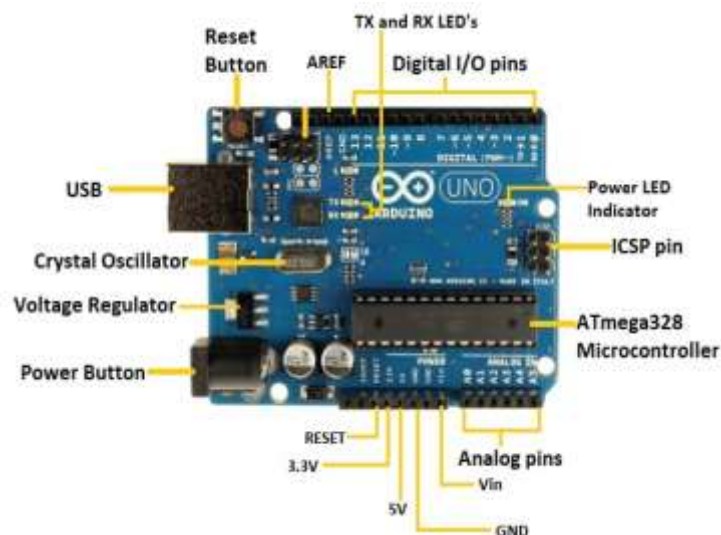

Fig.6: Arduino Uno

Light Emitting Diode: A light Emitting Diode (LED) is a two-lead semiconductor light source. The long terminal is positive and the short terminal is negative. It is p-n junction diode that emits light when activated. When a suitable current is applied to the leads, electrons are able to recombine with electron holes within the device, releasing energy in the form of photons. This effect is called electroluminescence, and the colour of the light is determined by the energy band gap of the semiconductor. LEDs are typically small and integrated optical components may be used to shape the radiation pattern.

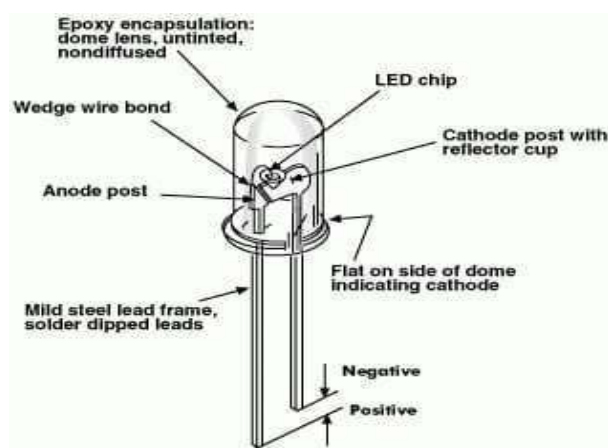

Fig.7: Light Emitting Diode

Solar Panel: Solar Energy Begins with the Sun. Solar Panels Are Also Known as "PV Panels" Which Are Used to Convert Light from The Sun, which is Composed of Particles of Energy Called "Photons", Into Electricity That Can Be Used to Power Electrical Loads. Solar Panels Can Be Used for A Wide Variety of Applications Including Remote Power

Systems for Cabins, Telecommunications Equipment, And for the Production of Electricity by Residential and Commercial Solar Electric Systems.



Fig.8: Solar Panel

Servo Motor: Micro Servo Motor SG90 is a tiny and lightweight server motor with high output power. It is an electromechanical device. Servo can rotate approximately 180 degrees (90 in each direction), and works just like the standard kinds but smaller. It produces torque and velocity based on the supplied current and voltage.

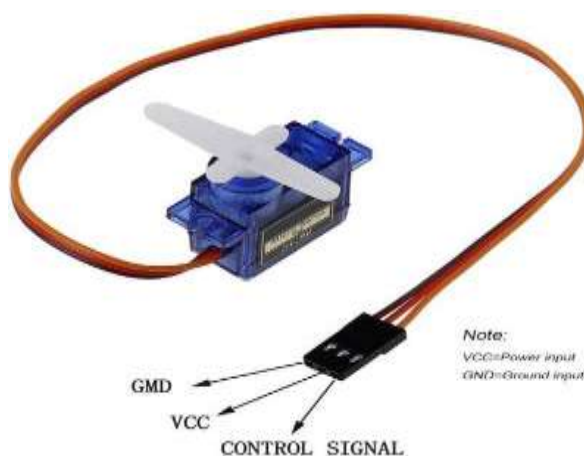

Fig.9: Servo Motor

4.2 Software Requirements

Raspbian

- Installation of Raspbian OS in Raspberry Pi.
- Raspberry Pi Supports C/C++ and Python version 2/3 by default.
- However, These Language Compiler or Interpreter can be installed on Raspbian OS.

Arduino IDE

- Downloading Arduino IDE software and then power up Arduino Board.

- Launching Arduino IDE.
- The Arduino integrated development environment is a cross platform Application, that is written in Java programming language and C/C++.

5. Implementation of Proposed Scheme

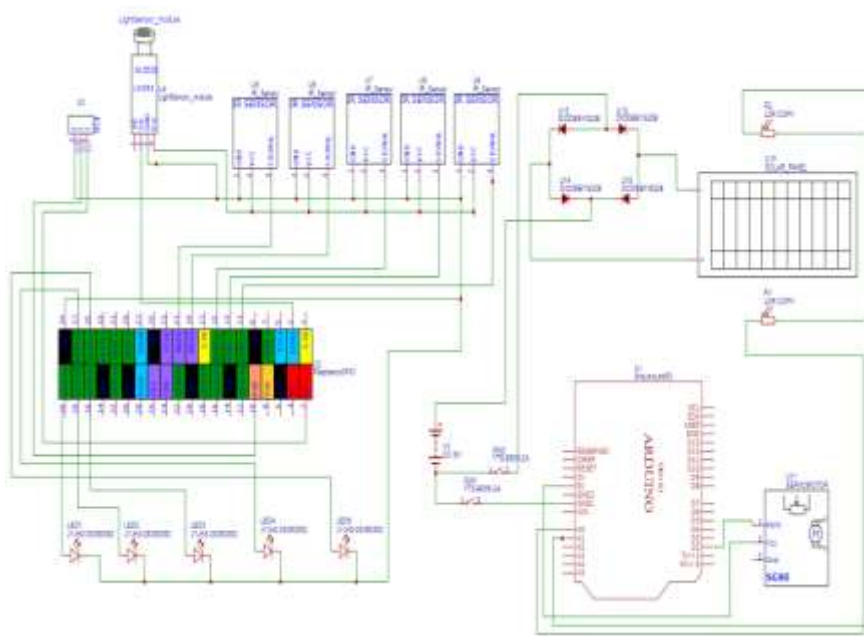

Fig.10: Schematic Diagram

Raspberry Pi is connected remotely in a hub for automatic turning ON/OFF the street lights. A person is going to control different streets in that hub. In between 6 and 11'O clock at Night, there are huge vehicles on the Roads. So PIR mode of Operation is used for automatic turning ON the whole street lights when Motion is detected for a period of time declared i.e., for 10 sec. During mid night, there are fewer vehicles on the roads. So IR mode of Operation is used for automatic turning ON the respective street light when the motion is detected. At the time of Festivals, LDR mode of Operation is used i.e., the street lights automatically turned ON at night and turned OFF at day time. Here Manual commands have to be given in the putty software for shifting the mode of Operation. The Solar Module is appended for maintaining less power consumption. There are two manual switches provided to maintain Raspberry pi and Arduino Board. Solar panels are used for charging batteries by changing daylight into electricity. Servo Motor is used to direct the solar panel. The energy which is stored in battery is used as power supply for the street lights. Whenever there is no charge in the battery then the second switch is used to process the Arduino board.

6. Results and Discussions

Fig.11 shows PIR mode of Operation, when the motion detected, the whole street lights ON for a period of 10 sec.

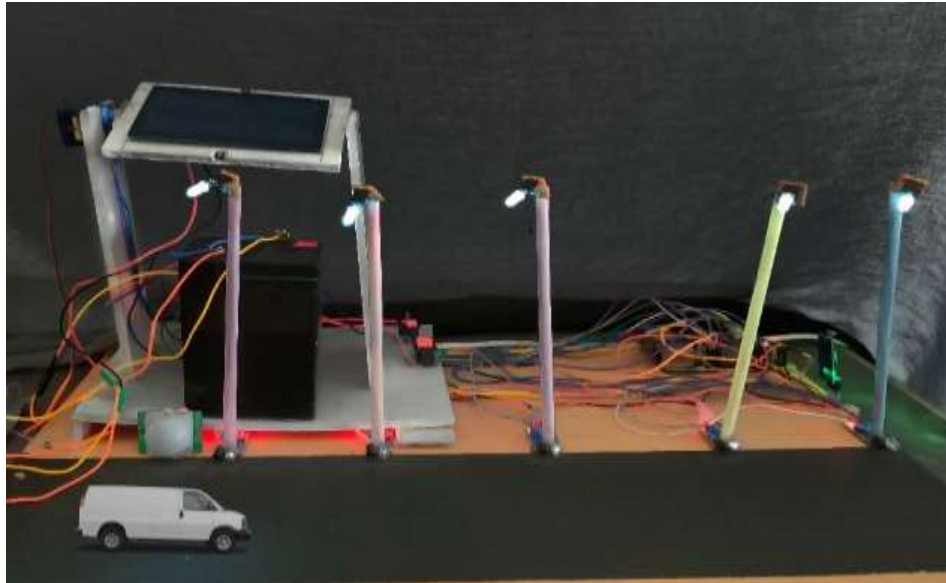

Fig.11: PIR Mode

Fig.12 shows IR mode of Operation, whenever there is a movement, the respective street lights turns on.

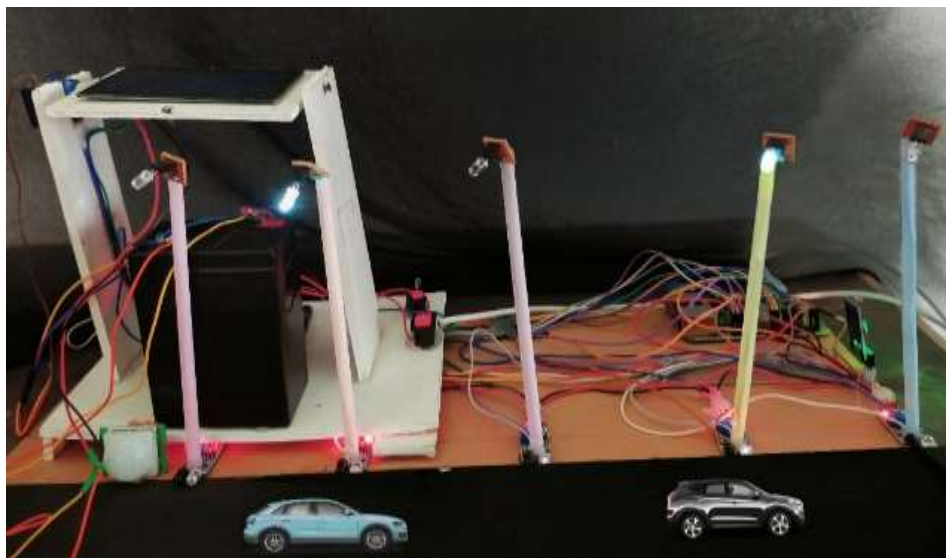

Fig.12: IR Mode.

Fig.13 shows LDR mode of Operation, in the dark condition the street lights will turns on.

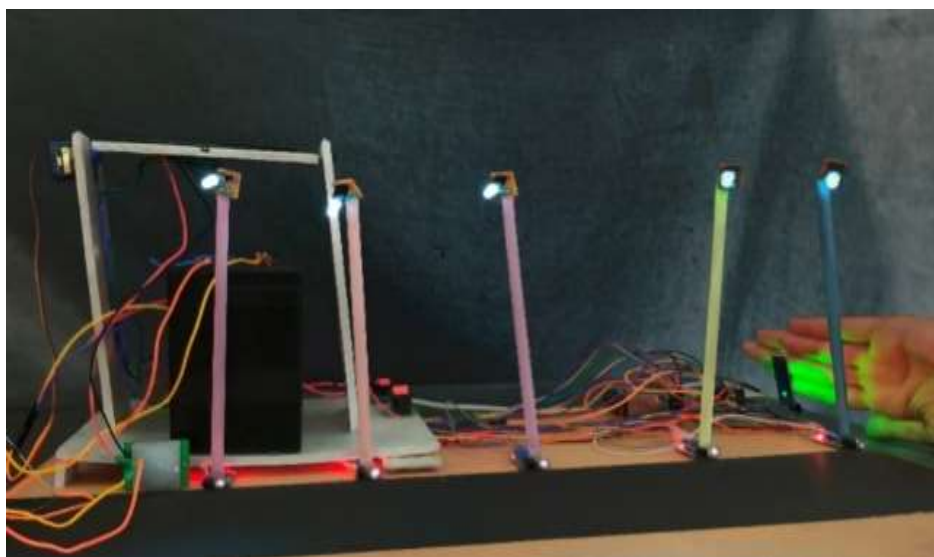

Fig.13: LDR Mode.

Fig.14 shows Solar Panel rotation when it hits by lightning which converts light energy into electricity.

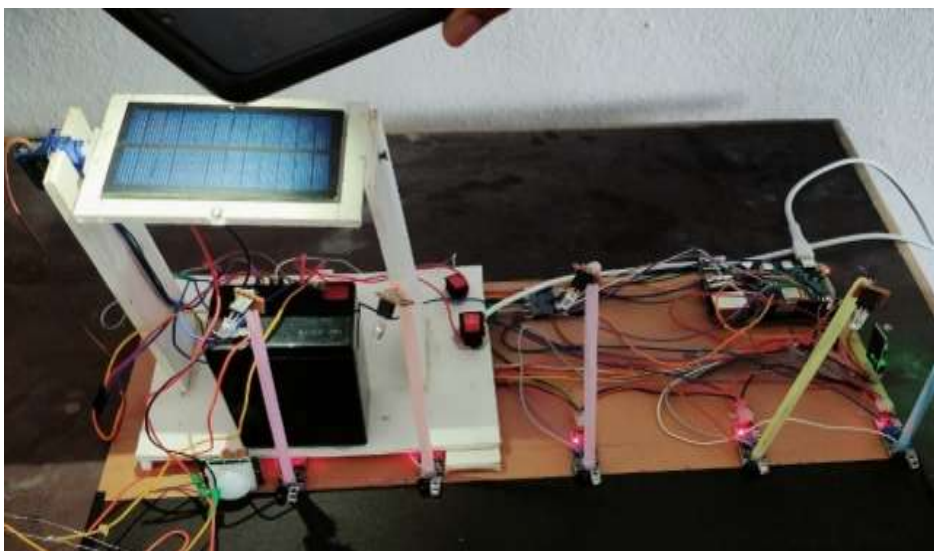

Fig.14: Solar Model.

7. Conclusion

This Research paper of Real Time Street Lights System has been implemented in order to provide ease to the people for safety measurements on the road during nights. The prototype of this project is build, Raspberry pi is used to control the Street lights by considering the commands in the software by wirelessly. Different Sensors are used in this project to maintain the modes of lightning system. We can control the street lights from the hub where the processor is maintained and can Identity which street light is turned On/Off. Hence, the solar module provides the safety way to save energy.

References

- [1] Vaigandla, K. K., & Venu, D. N. (2021). A survey on future generation wireless communications-5G: multiple access techniques, physical layer security, beamforming approach. *Journal of Information and Computational Science*, 11(9), 449-474.
- [2] Venu, D., Arun Kumar, A., & Vaigandla, K. K. (2022). Review of Internet of Things (IoT) for Future Generation Wireless Communications. *International Journal for Modern Trends in Science and Technology*, 8(03), 01-08.
- [3] Sujith, A. V. L. N., Swathi, R., Venkatasubramanian, R., Venu, N., Hemalatha, S., George, T., & Osman, S. M. (2022). Integrating nanomaterial and high-performance fuzzy-based machine learning approach for green energy conversion. *Journal of Nanomaterials*, 2022, 1-11.
- [4] Venu, N., & Anuradha, B. (2013, December). Integration of hyperbolic tangent and Gaussian kernels for fuzzy C-means algorithm with spatial information for MRI segmentation. In *2013 Fifth International Conference on Advanced Computing (ICoAC)* (pp. 280-285). IEEE.
- [5] Vaigandla, K. K., & Venu, D. N. (2021). Ber, snr and papr analysis of ofdma and sc-fdma. *GIS Science Journal*, ISSN, (1869-9391), 970-977.
- [6] Venu, N. (2014, April). Performance and evaluation of Gaussian kernels for FCM algorithm with mean filtering based denoising for MRI segmentation. In *2014 International Conference on Communication and Signal Processing* (pp. 1680-1685). IEEE.
- [7] Karthik Kumar Vaigandla, D. (2021, November). Survey on Massive MIMO: Technology, Challenges, Opportunities and Benefits. *YMER*, 271-282.
- [8] Venu, N., & Anuradha, B. (2015). Multi-Kernels Integration for FCM algorithm for Medical Image Segmentation Using Histogram Analysis. *Indian Journal of Science and Technology*, 8(34), 1-8.
- [9] Venu, N., Yuvaraj, D., Barnabas Paul Gladys, J., Pattnaik, O., Singh, G., Singh, M., & Adigo, A. G. (2022). Execution of Multitarget Node Selection Scheme for Target Position Alteration Monitoring in MANET. *Wireless Communications and Mobile Computing*, 2022.
- [10] Venu, N., Swathi, R., Sarangi, S. K., Subashini, V., Arulkumar, D., Ralhan, S., & Debtera, B. (2022). Optimization of Hello Message Broadcasting Prediction Model for Stability Analysis. *Wireless Communications & Mobile Computing (Online)*, 2022.
- [11] Venu, D. N. (2015). Analysis of Xtrinsic Sense MEMS Sensors. *International Journal of Advanced Research in Electrical, Electronics and Instrumentation Engineering*, 4 (8), 7228-7234.
- [12] Venu, N., & Anuradha, B. (2013). A novel multiple-kernel based fuzzy c-means algorithm with spatial information for medical image segmentation. *International Journal of Image Processing (IJIP)*, 7(3), 286.
- [13] Nookala Venu, A. (2018). Local mesh patterns for medical image segmentation. *Asian Pacific Journal of Health Sciences*, 5(1), 123-127.

- [14] Venu, N., & Anuradha, B. (2013). PSNR Based Fuzzy Clustering Algorithms for MRI Medical Image Segmentation. *International Journal of Image Processing and Visual Communication*, 2(2), 01-07.
- [15] Thouti, S., Venu, N., Rinku, D. R., Arora, A., & Rajeswaran, N. (2022). Investigation on identify the multiple issues in IoT devices using Convolutional Neural Network. *Measurement: Sensors*, 24, 100509.
- [16] Venu, N., Revanesh, M., Supriya, M., Talawar, M. B., Asha, A., Isaac, L. D., & Ferede, A. W. (2022). Energy Auditing and Broken Path Identification for Routing in Large-Scale Mobile Networks Using Machine Learning. *Wireless Communications and Mobile Computing*, 2022.
- [17] Kesavaiah, D. C., Goud, T. R., Rao, Y. S., & Venu, N. (2019). Radiation effect to MHD oscillatory flow in a channel filled through a porous medium with heat generation. *Journal of Mathematical Control Science and Applications*, 5(2), 71-80.
- [18] Nookala Venu, B. A. (2015). Medical Image Segmentation Using Kernal Based Fuzzy C-Means Algorithm. *International Journal of Engineering Innovation & Research* , 4 (1), 207-212.
- [19] Nookala Venu, D., Kumar, A., & Rao, M. A. S. (2022). BOTNET Attacks Detection in Internet of Things Using Machine Learning. *NeuroQuantology*, 20(4), 743-754.
- [20] Venu, N., & Anuradha, B. (2014, February). Multi-Hyperbolic Tangent Fuzzy C-means Algorithm for MRI Segmentation. In *Proceedings of International Conference on Advances in Communication, Network and Computing (CNC-2014)*, Elsevier (pp. 22-24).
- [21] Nookala Venu, S. W. (2022). A Wearable Medicines Recognition System using Deep Learning for People with Visual Impairment. *IJFANS*, 12(1), 2340-2348.
- [22] Nookala Venu, G. R. (2022). Smart Road Safety and Vehicle Accidents Prevention System for Mountain Road. *International Journal for Innovative Engineering Management and Research* , 11 (06), 209-214.
- [23] Nookala Venu, D., Kumar, A., & Rao, M. A. S. (2022). Smart Agriculture with Internet of Things and Unmanned Aerial Vehicles. *NeuroQuantology*, 20(6), 9904-9914.
- [24] Nookala Venu, D., Kumar, A., & Rao, M. A. S. (2022). Internet of Things Based Pulse Oximeter For Health Monitoring System. *NeuroQuantology*, 20(5), 5056-5066.
- [25] Venu, D. N. DA (2021). Comparison of Traditional Method with watershed threshold segmentation Technique. *The International journal of analytical and experimental modal analysis*, 13, 181-187.
- [26] Dr.Nookala Venu, D. K. (2022). Investigation on Internet of Things (IoT):Technologies, Challenges and Applications in Healthcare. *International Journal of Research* , XI (II), 208-218.
- [27] Kesavaiah, D. C., Goud, T. R., Venu, N., & Rao, Y. S. (2021). MHD Effect on Convective Flow of Dusty Viscous Fluid with Fraction in a Porous Medium and Heat Generation. *Journal of Mathematical Control Science and Applications*, 7(2).
- [28] Babu, K. R., Kesavaiah, D. C., Devika, B., & Venu, D. N. (2022). Radiation effect on MHD free convective heat absorbing Newtonian fluid with variable temperature. *NeuroQuantology*, 20(20), 1591-1599.

- [29] Kesavaiah, D. C., Ahmed, M., Reddy, K. V., & Venu, D. N. (2022). Heat and mass transfer effects over isothermal infinite vertical plate of Newtonian fluid with chemical reaction. *NeuroQuantology*, 20(20), 957-967.
- [30] Reddy, G. B., Kesavaiah, D. C., Reddy, G. B., & Venu, D. N. (2022). A note on heat transfer of MHD Jeffrey fluid over a stretching vertical surface through porous plate. *NeuroQuantology*, 20(15), 3472-3486.
- [31] Chenna Kesavaiah, D., Govinda Chowdary, P., Rami Reddy, G., & Nookala, V. (2022). Radiation, radiation absorption, chemical reaction and hall effects on unsteady flow past an isothermal vertical plate in a rotating fluid with variable mass diffusion with heat source. *NeuroQuantology*, 20(11), 800-815.
- [32] Kesavaiah, D. C., Prasad, M. K., Reddy, G. B., & Venu, N. (2022). Chemical Reaction, Heat and Mass Transfer Effects on MHD Peristaltic Transport in A Vertical Channel Through Space Porosity And Wall Properties. *NeuroQuantology*, 20(11), 781-794.
- [33] Kesavaiah, D. C., Reddy, G. B., Kiran, A., & Venu, D. N. (2022). MHD effect on boundary layer flow of an unsteady incompressible micropolar fluid over a stretching surface. *NeuroQuantology*, 20(8), 9442-9452.
- [34] Kesavaiah, D. C., Chowdary, P. G., Chitra, M., & Venu, D. N. (2022). Chemical reaction and MHD effects on free convection flow of a viscoelastic dusty gas through a semi infinite plate moving with radiative heat transfer. *NeuroQuantology*, 20(8), 9425-9434.
- [35] Mr.RadhaKrishna Karne, M. M. (2022). Applications of IoT on Intrusion Detection System with Deep Learning Analysis. *International Jourfor Innovative Engineering and Management Research* , 11 (06), 227-232.
- [36] Venu, N., & Anuradha, B. (2015). Two different multi-kernels for fuzzy C-means algorithm for medical image segmentation. *Int. J. Eng. Trends Technol.(IJETT)*, 20, 77-82.
- [37] Kesavaiah, D. C., Goud, T. R., Venu, N., & Rao, Y. S. (2017). Analytical Study on Induced Magnetic Field with Radiating Fluid over a Porous Vertical Plate with Heat Generation. *Journal of Mathematical Control Science and Applications*, 3(2).
- [38] Dr. Nookala Venu, D. A. (2022, March). Routing and Self-Directed Vehicle Data Collection for Minimizing Data Loss in Underwater Network. *IJFANS International Journal of Food and Nutritional Sciences* , 170-183.
- [39] Dr. Nookala Venu, D. A. (2022). Fuzzy Based Resource Management Approach for the Selection of Biomass Material. *IJFANS International Journal of Food and Nutritional Sciences* , 12 (2), 83-97.
- [40] Ravindra Kumar Agarwal, D. S. (2022). A Novel Dates Palm Processing and Packaging Management System based on IoT and Deep Learning Approaches. *IJFANS International Journal of Food and Nutritional Sciences* , 11 (8), 1139-1151.
- [41] Manthur Sreeramulu Manjunath, P. K. (2022). An Enhanced Machine Learning Approach For Identifying Paddy Crop Blast Disease Management Using Fuzzy Logic. *IJFANS International Journal of Food and Nutritional Sciences* , 11 (8), 1152-1163.
- [42] K.P.Senthilkumar, K. C. (2022). Machine Learning Based Analysis and Classification of Rhizome Rot Disease in Turmeric Plants. *IJFANS International Journal of Food and Nutritional Sciences* , 11 (8), 1179-1190.

- [43] Sowmya Jagadeesan, B. B. (2022). A Perishable Food Monitoring Model Based on IoT and Deep Learning to Improve Food Hygiene and Safety Management. *IJFANS International Journal of Food and Nutritional Sciences* , 11 (8), 1164-1178.
- [44] Nookala Venu, S. K. (2022). Machine Learning Application for Medicine Distribution Management System. *IJFANS International Journal of Food and Nutritional Sciences* , 11 (1), 2323-2330.
- [45] Reddy, A. V., Kumar, A. A., Venu, N., & Reddy, R. V. K. (2022). On optimization efficiency of scalability and availability of cloud-based software services using scale rate limiting algorithm. *Measurement: Sensors*, 24, 100468.
- [46] D. Chenna Kesavaiah, T. Ramakrishna Goud, Y. V. Seshagiri Rao, Nookala Venu (2019): Radiation effect to MHD oscillatory flow in a channel filled through a porous medium with heat generation, *Journal of Mathematical Control Science and Applications*, Vol. 5 (2), pp. 71-80.
- [47] Venu, D. N. (2022). Smart Agriculture Remote Monitoring System Using Low Power IOT Network. *IJFANS International Journal of Food and Nutritional Sciences*, 11 (6), 327-340.
- [48] Venu, D. N. (2022). IOT Surveillance Robot Using ESP-32 Wi-Fi CAM & Arduino. *IJFANS International Journal of Food and Nutritional Sciences* , 11 (5), 198-205.
- [49] Nookala Venu, N. S. (2022). Study and Experimental Analysis on FBMC and OFDM. *International Journal for Innovative Engineering and Management Research*, 11 (6), 49-53.
- [50] Sandhya rani B, S. K. (2022). Vehicle Fuel Level Monitor and Locate the Nearest Petrol Pumps using IoT. *International Journal for Innovative Engineering and Management Research* , 11 (06), 233-240.
- [51] Nookala Venu, K. A. (2022). Face Mask Detection System Using Python Open CV, *International Journal for Innovative Engineering and Management Research*, 11 (6), 28-32.
- [52] Nookala Venu, V. M. (2022). Alcohol Detection and Engine Locking System. *International Journal for Innovative Engineering and Management Research* , 11 (06), 157-160.
- [53] Nookala Venu, C. B. (2022). Wireless Night Vision Camera on War Spying Robot. *International Journal for Innovative Engineering and Management Research* , 11 (06), 123-128.
- [54] Venu, D. N. (2022). IOT Based Enabled Parking System in Public Areas. *IJFANS International Journal of Food and Nutritional Sciences*, 11 (4), 162-174.
- [55] Venu, D. N. (2022). IOT Based Speech Recognition System to Improve the Performance of Emotion Detection. *IJFANS International Journal of Food and Nutritional Sciences*, 11 (3), 92-102.
- [56] Dr.Nookala Venu, M. S. (2018). Local Maximum Edge Binary Patterns for Medical Image Segmentation. *International Journal of Engineering and Techniques*, 4 (1), 504-509.
- [57] Venu, N., & Anuradha, B. (2016). Multi-hyperbolic tangent fuzzy c-means algorithm with spatial information for MRI segmentation. *International Journal of Signal and Imaging Systems Engineering*, 9(3), 135-145.

- [58] Venu, N., & Anuradha, B. (2015). Hyperbolic Tangent Fuzzy C-Means Algorithm with Spatial Information for MRI Segmentation. *International Journal of Applied Engineering Research*, 10(7), 18241-18257.
- [59] Venu, N., & Anuradha, B. (2015, April). Two different multi-kernels integration with spatial information in fuzzy C-means algorithm for medical image segmentation. In *2015 International Conference on Communications and Signal Processing (ICCSP)* (pp. 0020-0025). IEEE.
- [60] Nookala Venu, B. (2015). MRI Image Segmentation Using Gaussian Kernel Based Fuzzy C-Means Algorithm. *International Journal of Electronics Communication and Computer Engineering*, 6 (1), 140-145.
- [61] Venu, N., & Anuradha, B. (2015). Evaluation of Integrated Hyperbolic Tangent and Gaussian Kernels Functions for Medical Image Segmentation. *International Journal of Applied Engineering Research*, 10(18), 38684-38689.
- [62] Anita Tuljappa, V. N. (2022). Dufour and Chemical Reaction Effects on Two Dimensional incompressible flow of a Viscous fluid over Moving vertical surface. *NeuroQuantology*, 63-74.
- [63] Ch. Achi Reddy, V. N. (2022). Magnetic Field And Chemical Reaction Effects on Unsteady Flow Past A Stimulate Isothermal Infinite Vertical Plate. *NeuroQuantology*, 20 (16), 5360-5373.
- [64] Sowmya Jagadeesan, M. K. (2022). Implementation of an Internet of Things and Machine learning Based Smart Medicine Assistive System for Patients with Memory Impairment. *IJFANS International Journal of Food and Nutritional Sciences*, 1191-1202.
- [65] Venu, D. N. (2023). Design Analysis and Classification of Digital Transmission Based Composite Relay and Artificial Neural Network Approach. *IJFANS International Journal of Food and Nutritional Sciences*, 12 (1), 680-63.
- [66] Venu, D. N. (2023). Biomass Studies on Pyrolysis of Sugarcane Bagasse and Cashew Nut Shell for Liquid Fuels. *IJFANS International Journal of Food and Nutritional Sciences*, 11 (1), 695-706.
- [67] Venu, D. N. (2023). Synthesis and Study on Feasibility of Ethanol Production from Leachate of Pretreatment of Sugarcane Bagasse. *IJFANS International Journal of Food and Nutritional Sciences*, 12 (1), 707-715.
- [68] Venu, D. N. (2022). Design and Performance Analysis of Super Critical Fluid Extraction for SC-CO₂. *IJFANS International Journal of Food and Nutritional Sciences*, 11 (12), 3854-3865.
- [69] Venu, D. N. (2022). Supercritical Fluid Evaluation and Extraction of Phenol from Sugarcane Bagasse Pyrolysis Oil. *IJFANS International Journal of Food and Nutritional Sciences*, 11 (12), 3866-3876.
- [70] Sandhya rani, D. V. (2022). IOT Based Smart Irrigation System Using Node MCU. *International Journal For Innovative Engineering and Management Research*, 11 (6), 100-106.
- [71] Dr.Nookala Venu, A. E. (2022). Low Power Area Efficient ALU with Low Power Full Adder. *International Journal For Innovative Engineering and Management Research*, 11 (06), 167-170.

- [72] Nookala Venu, B.Anuradha"Brain MRI Medical Image Segmentation Using Fuzzy Based Clustering Algorithms", *International Journal of Engineering Trends and Technology (IJETT)*, V22 (2), 83-88 April 2015. ISSN: 2231-5381. www.ijettjournal.org. published by seventh sense research group.
- [73] Dr. Nookala Venu, D. K. (2023). Implementation of Hello Time Gaps Tracking Scheme for Network Stability Analysis in MANET. *European Chemical Bulletin* , 12 (8), 5011-5026.
- [74] Ch.Shashi Kumar, K. R. (2023). Chemical Reaction and Hall Effects on Unsteady Flow Past an Isothermal Vertical Plate in a Rotating Fluid with Variable Mass Diffusion. *European Chemical Bulletin*, 12 (8), 4991-5010.
- [75] Venu, D. N. (2022). Classification Analysis for Local Mesh Patterns Using Medical Image Segmentation. *IJFANS International Journal of Food and Nutritional Sciences*, 11 (12), 5232-5241.
- [76] Venu, D. N. (2022). PSNR Based Levels Evaluation of FCM Algorithm with Peak and Valley Filtering Based Brain Images. *IJFANS International Journal of Food and Nutritional Sciences*, 11 (12), 5242-5253.
- [77] Venu, D. N. (2023). Segmentation Analysis for Local Maximum Edge Binary Patterns using Medical Images. *IJFANS International Journal of Food and Nutritional Sciences*, 12 (1), 917-927.
- [78] Venu, D. N. (2023). PSNR Based Evaluation of Spatial Guassian Kernals For FCM Algorithm with Mean and Median Filtering Based Denoising for MRI Segmentation. *IJFANS International Journal of Food and Nutritional Sciences*, 12 (1), 928-939.
- [79] Venu, D. N. (2022). Multi Guassian Kernals for FCM Algorithm with Mean and Peak-Valley-Kernal Filtering Based Denoising for MRI Segmentation Using PSNR Analysis. *IJFANS International Journal of Food and Nutritional Sciences*, 11 (11), 1965-1976.
- [80] Dr.A.Arun Kumar, D. N. (2023). Enhanced Security Packet Acceptance for Target Position Alteration using Multi Acceptor Scheme Assigning Algorithm in MANET. *European Chemical Bulletin* , 12 (8), 7003-7018.
- [81] Dr.A.Arun Kumar, D. N. (2023). Analysis and Enhancement of Energy Auditing Routing for Identification of Broken Paths in Mobile Adhoc Networks. *European Chemical Bulletin* , 12 (8), 7019-7034.
- [82] Dr. Sowgani Ramakrishna, D. A. (2023). Computational Mathematical Modelling of Radiative Chemical Reaction and Hall Effects on unsteady flow past an Isothermal Vertical Plate with radiation and Heat Absorption. *European Chemical Bulletin* , 12 (8), 8436-8452.