



Solar Panel Fault Detection System using IoT

P. Sampurna Lakshmi¹, Dr.S. Sivagama Sundari², Dr.R. Manjula sri³

¹ Research Scholar, Department of Electronics and Instrumentation Engineering, Annamalai University, Chidambaram, Tamil Nadu, India.

² Professor, Department of Electronics and Instrumentation Engineering, Annamalai University, Chidambaram, Tamil Nadu, India.

³ Professor, Department of Electronics and Instrumentation Engineering, VNRVJIET, Secunderabad, Telangana, India.

Email: ¹ sampurnalakshmi_p@vnrvjiet.in, ² sivagamasundari67@gmail.com,
³ manjulasree_r@vnrvjiet.in

Abstract

The solar parks are now quickly becoming one of the most significant renewable form of energy systems, hence there is a pressing need for more streamlined use of the aid they provide, as well as error discernment and performance difficulties. The Internet Of Things (IoT) technology attempts to bridge the gap by providing low-priced, modest and long-term results for solar park efficiency. We describe a monitoring and alerting system in this project that is employed in the early identification of Potential Induced Degradation (PID) and Hotspots failures, which can result in a considerable reduction in solar panel performance. Certain practical characteristics like as temperature, voltage, and humidity are continually monitored at the panel level in order to do this. It is mainly focused on the installation of Internet Of Things for remote monitoring and performance evaluation of a solar facility. This will make preventative maintenance, solar panel defect detection, and real-time monitoring much easier. Solar towns, smart villages, micro grids, and solar street lighting are just a few of the possibilities for this technology. In the present-day scenario, use of renewable energy has increased at a higher rate than at any previous time in history. The proposed system calls for an online display of solar energy's power use as a sustainable energy source. This monitoring is carried out with the help of an Arduino and an IoT server.

Keywords: Internet of things, PID and hot spot failures.

1. Introduction

1.1 Objective

The power usage is a crucial impending concern in our society. Some non-renewable energy sources, such as thermal and nuclear energy, are costly and dangerous to humanity. Traditional energy sources are finite, and they also pollute the environment. An environmentally friendly system will be a better answer to these issues. The goal of this project is to monitor and manage the voltage output of a solar panel that is kept at a remote place. Using the Internet of Things to monitor the output in the server (IOT). The output page is accessed through the server page, which has a unique IP address. Relay boards and circuits

are used to control the outputs of solar panels further. The procedure of monitoring and regulating is made simple and efficient with the help of this system.

With solar parks quickly becoming perhaps the main sustainable power frameworks, there is a pressing need for more effective utilization of the administrations they give, just as blunder recognition and execution troubles. To accomplish so, non-trivial characteristics including as humidity, temperature, and voltage are continually checked at the board level and prepared in a cloud-based stage to distinguish these events early. With solar panels rapidly getting perhaps the main sustainable power frameworks, there is a squeezing need for more productive utilization of the administrations they give, just as blunder location and execution challenges. The Internet Of Things (IoT) technology hopes to bridge the gap by providing low-price, long-term solutions for the effective running of the solar parks. In this research, we discussed a checking and alarming framework dependent on WSN advancements for the timely recognition of PID and Hotspots failures, which can result in a considerable decline in solar panel performance.

For establishing a robust and extensive coverage area, the sensors communicate data to a consolidated local sink integrant consisting of a ad hoc Wireless Sensor Network framework. Following that, the data is sent to an IOT server, where destined diagnostic techniques are being implemented. We show our approach's reference architecture, as well as the relevant hardware and firmware structure, separate components, as well as the installation procedure and a real-world use scenario.

1.2 Outline

Solar power facilities must be closely monitored to ensure maximum power output. This allows for the evaluation of actual power output from power plants, as well as the monitoring of malfunctioning solar arrays, inter-connections, and filth accumulation on panels that reduce yield, as well as other problems that affect production. So, in this paper, we present a modified Internet Of Things based solar oriented power observing framework that empowers computerized solar based power checking from anyplace over the web. To monitor solar panel parameters, we use an Arduino-based system. This project monitors the panel in real time and sends the output to an Internet Of Things device through the web. We're using Internet Of Things Thing is meant to send solar power parameters to the Internet Of Things Thing speak server over the web.

Fossil fuels are essential for the generation of electricity all over the world. As global energy usage rises, the globe, including our country, is confronted with a shortage of backup power. The proposed model's core premise is to use the Internet of Things to monitor and manage the voltage output of solar panels from a remote location (IOT). By enhancing performance and efficiency, an integrated wired/wireless solution allows for quick technological advancement. The entire ranch can be controlled by an IOT system, which can be constructed according to the application's requirements.

Energy productivity is acknowledged as a society's major issues, as it is intertwined with environmental issues and CO₂ discharge. Photovoltaic cells (PV) can provide a clean energy yield which can help to considerably reduce worldwide environmental problems. It has recently experienced remarkable growth, demonstrating that it is an abiding and worthwhile technology. By 2050, this growing speed is predicted to reach a sixteen percent of worldwide

power consumption. To that aim, both the educational and manufacturing examination and expansion units are looking for novel ways to increase coherence and distinguishability while lowering production and maintenance costs. PV has been demonstrated to be reliable in real-world situations. However, there are still instances where reliability appears to be a factor in failure.

We propose a system in this project that can spot potential induced degradation (PID) and Hot-spots effects that can result in a considerable decline in performance. PID is a key issue that is regularly observed in existing PV installations, and it has been acknowledged as a reliability barrier for solar modules manufactured. As a key subject that is regularly encountered in real PV insertion, solar modules are made. The sub units that appear to be problem, in particular, have high temperatures as compared to their nearby cells. One of the most usual scenarios is observed to be the PID effected cells are found on the edges, particularly on the panel near the string's negative termination. Temperature and humidity are two key elements that can cause a PID outcome in a solar cell. In the present research, we present a cheap Internet of Things system based on Wireless Sensor Networks that monitors ambient and PV conditions and allows for analysis, which leads to variables and alerts for the effects. Because the system can alarm if the occurrences will be recognized, a potential rejuvenation procedure to keep the panel's energy production at standard levels can take place.

Recent technology advancements in the sensor, wireless communications, and cloud-based domains have started the Internet of Things idea in a wide range of solar power plant applications. Many of them concentrate on optimizing services, while others focus on harvesting resource monitoring and management. Furthermore, a WSN-based system is aimed at providing real-time features and experimenting, such as energy production reports, security system, and so on, both at the cell and infrastructure scales of a solar based power plant. Another solar module observation and diagnosis friendly system is given in a more dispersed method. On the other side, a lot of study has also been done about the production difficulties that the solar parks handle and the detection methods or systems that may be implemented to solve them.

A few authors, specifically, want to extend the lifetime of solar panels that have been subjected to external potentials that can cause PID. The Simulations evaluating the impact of cell attributes on PID, as well as the preconditions for PID at the cell level, have revealed that PID can be offed or decreased at the panel and the system levels. There was also a study that looked at the effects of the parameters discussed above on PID.

1.3 Motivation

Renewable energy is extracted from natural resources that regenerates in less than a human lifetime without minimizing the existing resources. These resources, for example sunshine, wind energy, rains, oceanic tides, all kinds of waves, biomass energies, and thermal energy stored in the earth's crust, have the advantage of being practically everywhere available in one form or another. They are practically eternal. What is more, they do not show much of an effect on the climatic conditions or the ecosystem. On the other hand, there are fossil fuels including crude oil, mined coal, and the natural gas used in a variety of applications are only available in countable quantities. They might gradually get over if we continue to extract.

Despite the fact that they are created naturally, they do not replenish as quickly as we humans consume them.

Any kind of energy source has consequences on the surrounding environment, similar to human acts. Sustainable energy is no despite, as every source is coming with its unique trade-offs. But, the advantages of viable energy as compared to fossil fuels are apparent, starting from reduced water and land consumption and including air pollution and water pollution, wildlife and habitat extinction, and no or decreased greenhouse gas emissions. The burning of the fossil fuels for energy discharges a large amount of greenhouse gases, which is adding to global warming. Even when considering whole cycle of the technologies, the maximum usage of renewable energy sources emits little to zero emissions.

Some solar panels have a warranty of up to 25 years. Of course, as with any warranty, this does not imply that the product will cease to function after the warranty period has expired. Simply put, the corporation will accept responsibility for any decrease in efficiency during this time period. That is to say, the solar system is predicted to perform well long after this time period has passed. It minimizes global warming by lowering fossil fuel creation by combining dead plants and animals with carbon and other gases. As a result of nuclear fusion, fossil fuels containing a large amount of carbon are formed and released into the atmosphere. Many people would have gone without power if renewable energy hadn't been invented. Or they would have had to spend a lot of money to have power. Many people live in off-the-grid communities. Several people do not have easy access to electricity. Solar, on the other hand, solves such issues. You can have power without breaking the bank or relying on the electricity grid. Aside from generating electricity (photovoltaics), solar power is also utilized to generate heat (solar thermal). The distillation of water is another application of solar electricity. Everyone should be excited about and ready to embrace solar energy as a technological revolution.

1.4 Scope for the Work

IoT receives about 99 percent of all applications. Consumer electronics, office automation, industrial automation, biomedical engineering, wireless communication, data communication, telecommunications, transportation, military, and other segments all employ this technology, making it one of the fastest growing areas. A solar power plant includes a number of solar panels creating direct current electricity proportionate to strength the sun possesses. The generated electricity is subsequently transformed into alternating current by the inverters of the parks, that goes with the national electricity distribution network. The park is built around the central inverters that work in appropriate substations. PV unit (or the panel) is the smallest solar park module, consisting of a collection of linked PV sub-unit encased in protected layers and installed on an aluminium frame. However, there are a number of factors that might limit the efficiency of solar panels. The PID effect is one such cause. PID arises many months to years after the installment of solar park and its uniqueness resides believing that it can begin with a one panel and progressively spread to others, eventually affecting remaining panels in the sun park if they are not addressed promptly.

Hotspots are another factor that might degrade a solar park's performance. Hotspots are high-temperature zones which occurs generally on the PV modules and have a negative impact on the park's performance. Firstly, a decrease occurs locally in panel efficacy and that is

detected, which leads to a reduction in overall panel output power and, finally, material degradation and failure in the Hotspot area. We describe an Internet based system for solar park detection of faulty panels and efficient monitoring in this project. The technology includes of sensor motes that are distributed onto solar panels and are outfitted with various sensors. The data collected by the sensors is then forwarded to be processed. The relevant steps are initiated if failure is found later the data has been processed.

2. Methodology

This chapter provides an overview of the project's hardware implementation. It uses a block diagram and a circuit diagram to discuss the design and how it works, as well as a detailed explanation of the circuit diagram. It explains the atmega328 microcontroller's functionality, timer programming, serial connection, and interrupts. It also goes over the different modules that were implemented in this project

Project Design:

The venture plan execution can be partitioned in two sections:

- Hardware implementation
- Firmware implementation

The design's block diagram is depicted in the diagram below. Power supply, voltage sensor, Humidity and temperature sensor, Solar panels are included.

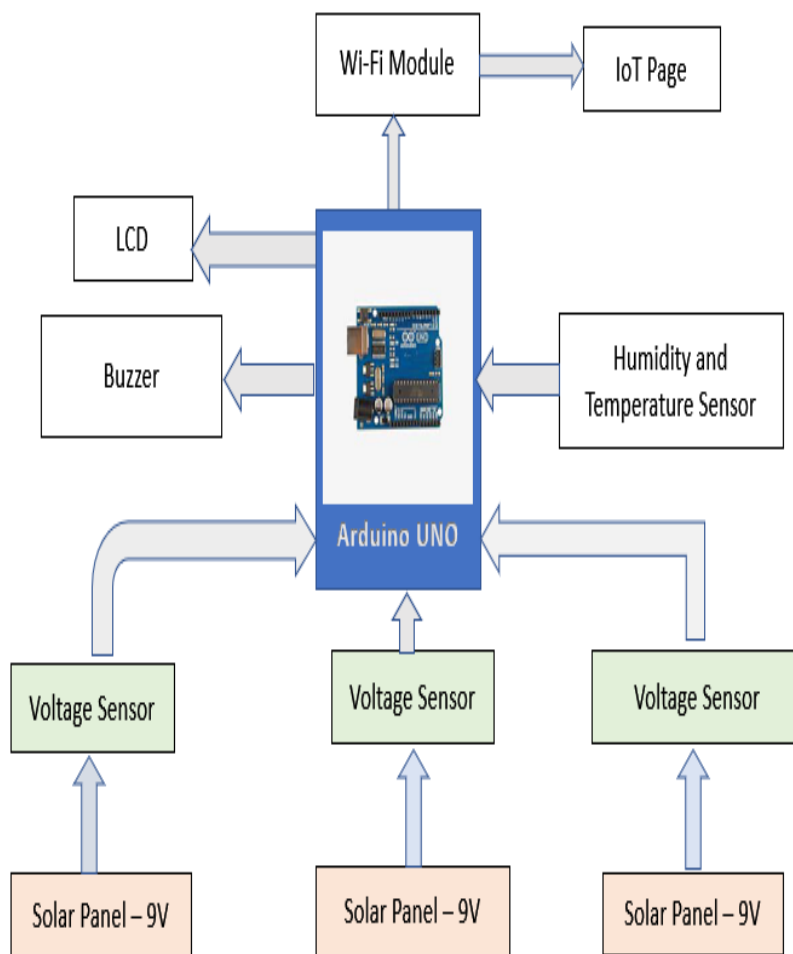

Figure 1. Block diagram of solar panels monitoring system



Figure 2 Hardware diagram

Solar panels are used in photovoltaic (PV) power systems to gather energy from the sun. A PV panel is a solar cell assembly that has been packaged. Solar panels, a Maximum Peak Power Tracking (MPPT) controller, an inverter system, and batteries are all common components of a photovoltaic power system. It is vital to choose the right solar panel and battery for the PV power system to work efficiently.

A voltage sensor is a gadget that actions and ascertains the measure of voltage in an item. Voltage sensors can tell whether the voltage is AC or DC. The voltage is the sensor's information, while the switches, simple voltage signal, current sign, or discernible sign are the sensor's yield. The Voltage Sensor is a precise, minimal expense voltage sensor. It depends on the resistive voltage divider configuration approach. It can decrease the info voltage of the red terminal connector by multiple times.

- **IOT Page**

The Internet of Things (IoT) is the idea of connecting any contraption to the Web and other associated gadgets (as long as it's anything but an on/off switch). The Web of Things (IoT) is a gigantic organization of interconnected things and individuals that all gather and offer information on how they are used and their general surroundings.

Gadgets and things with worked in sensors are associated with a Web of Things stage, which joins information from different gadgets and applies examination to impart the most valuable data to applications custom fitted to singular requirements.

These complex IoT arrangements can distinguish decisively which information is helpful and which might be securely overlooked. This information can be utilized to spot designs, make proposals, and recognize expected issues before they emerge.

The information gathered by connected gadgets permits me to make educated decisions about what segments to store dependent on ongoing information, setting aside personal time and cash.

3. Conclusion and Future Scope

The Solar Park Health Monitoring System was successfully implemented using a microcontroller. The communication between the different components in the design is done appropriately, with no interference.

When the temperature rises over the specified point, the system flags the solar panel as faulty and sends the information to a web page. If the solar panel's humidity falls below the set

point, the system flags it as a failure and sends the data to a web page, as well as displaying the same warning on the LCD. The system flags the panel as faulty if the voltage value is less than 2 volts and more than 20 volts. The status of the panel will be posted on the IOT page on a regular basis.

Orcad is used to design the circuit, which is then implemented on the microcontroller board. Both the software simulator and the hardware design have been used to verify the performance. The entire circuit has been functionally tested and is operating in accordance with the application software. It can be stated that the design used in this study provides portability and flexibility, as well as data transfer at a low power consumption.

The output is shown in the IoT web page as shown in the picture below

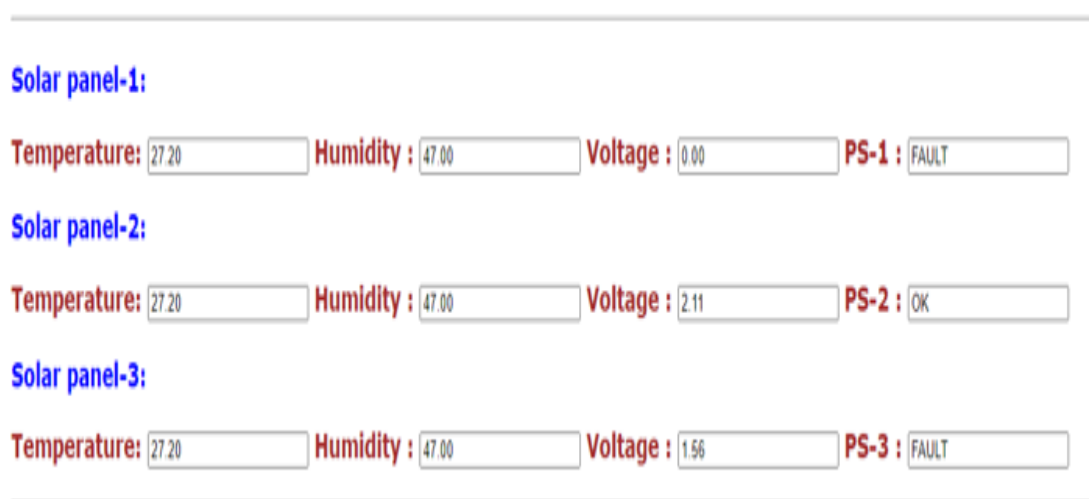

Figure 3 output displayed on webpage

4. Future Scope

We'd prefer to fuse AI models and calculations that can gauge the PID in its beginning phases, preferably with less detecting assets, as future updates. To do as such, a critical volume of information throughout a significant stretch of time is expected to reveal the PID phenomenon's advancement stages. Besides, exploring the use of Large Information advancements can help us increment the presentation and precision of our answer for troublesome and significant difficulties.

References

- [1]. Fariyah Shariff, Nasrudin Abd Rahim, Hew Wooi Ping. "Photovoltaic Remote Monitoring System Based on GSM", IEEE. Conference on Clean Energy and Technology (CEAT), 2013.
- [2]. Oussama Ben Belghith, Lasaad Sbita "Remote GSM module monitoring and Photovoltaic System control", First International Conference on Green Energy ICGE 2014.
- [3]. Chang-Sic Choi, Jin-Doo Jeong, Jinsoo Han, Wan-Ki Park, Il-Woo Lee "Implementation of IoT based PV Monitoring System with Message Queuing Telemetry Transfer protocol and Smart Utility Network ", 978-1-5090-4032-2/17/\$31.00 ©2017 IEEE.
- [4]. Andreas.S.Spanias, "Solar Energy Management as an Internet of Things (IoT) Application". SenSIP Center, School of ECEE, Arizona State University, 2017.

- [5]. Ankit Kekre, Suresh K. Gawre, “619 Solar Photovoltaic Remote Monitoring System Using IOT ” Proceeding International conference on Recent Innovations in Signal Processing and Embedded Systems (RISE -2017) 27-29 October, ISBN 978-1- 5090-4760-4/17/\$31.00©2017 IEEE.
- [6]. Dr Pushan Kumar Dutta, Dr Kethepalli Mallikarjuna “Sensor based Solar Tracker System using Electronic Circuits for Moisture Detection and AutoIrrigation”,IEEE International Conference on Power, Control, Signals and Instrumentation Engineering (ICPCSI-2017).
- [7]. Nallapaneni Manoj Kumar 1, Karthik Atluri 2, Sriteja Palaparthi 3 “Internet of Things (IoT) in Photovoltaic Systems”,2018 National Power Engineering Conference (NPEC), 2018 National Power Engineering Conference (NPEC) 978-1-5386- 3803-3/18/\$31.00 ©2018 IEEE .