



DESIGN AND PERFORMANCE EVALUATION GRID-CONNECTED PV SYSTEM USING BIO-INSPIRED MPPT

R.Padmavathi

Department of Electrical and Electronics Engineering,
Rajalakshmi Engineering College, Chennai, TamilNadu, 602105, India
dpadma2021@gmail.com

R.Kalaivani

Department of Electrical and Electronics Engineering,
Rajalakshmi Engineering College, Chennai, TamilNadu, 602105, India

Abstract— Power generation as well as distribution systems are experiencing considerable modifications, due to advanced technologies like incorporation of extensive renewable energy production, improved transmission as well as control schemes, and increased storage capacity. Among various renewable energy resources, solar PV (Photovoltaic) based energy generation system is widely used because of its static structure, minimal size as well as low maintenance cost. But, the output voltage bring about by the PV system is generally minimum and it affects the efficiency and reliability of the system. Hence, there is a need for a high switching frequency device to uplift the minimal PV voltage. This is obtained by incorporating the PV panel with a DC/DC converter which boosts the PV voltage and improves the energy extraction. In this work, the single-ended primary-inductor converter (SEPIC) has been utilized for better power tracking from PV modules. SEPIC Converter accomplish with impedance matching power device and provides utmost PV power tracking. Space vector pulse width modulation has been utilized as an inverter control. Finally, the proposed system is simulated in MATLAB and Simulink software to validate the analytical and theoretical concepts along with the efficacy of the proposed model.

Keywords— *SEPIC Converter, PV Panel, MATLAB, MPPT, THD, Non-linear Load*

I. INTRODUCTION

The fast penetration of RES, such as PVs, increases the popularity of DC-AC power converters at grid-connected applications [1]–[5]. However, the new PV architectures have independent PV modules with low input voltages [6]–[9]. Moreover, the partial shading scenarios force this voltage to be time-variant [8], [10]. This characteristic makes the traditional VSI and CSI have some limitations due to voltage gain property because VSI and CSI are a buck and boost inverter topologies, respectively [3], [8]–[10]. Therefore, inverter topologies with buck/boost features are the modern PV architectures trend with additional functionalities such as voltage isolation, modularity, scalability, and bi-directional power capability [8], [10]. Generally, PV modules are directly connected to the utility grid. The issues related to leakage current and grid-operators safety have been increased. Isolated topologies are recommended to cut the leakage currents, decrease CMV, and EMI to maintain human safety [8], [10]. Also, defining the number of connected PV modules with the utilized inverter topology needs a modular inverter to increase the system's flexibility and optimize it for further extension in the future [8]. Furthermore, increasing the battery systems at the current utility grids, especially the advanced Electric Vehicles (EVs) and charging/discharging stations, put a new direction by optimizing DC-AC inverters with bi-directional power competence [11], [12]. Traditionally, a DC-DC boost converter or isolated DCDC converters such as flyback, Cuk, and SEPIC converters were added to traditional VSI to step up the low DC input voltage and generate a buck-boost inverter.

Isolated and non-isolated high step-up converters are later utilized to achieve higher voltage from PV. In Isolated converters, transformer is used to achieve high voltage gain. But leakage inductances, voltage spikes across the switch and substantial switching losses degrades the efficiency of this converter [13, 14].

When compared to the isolated converter, the non-isolated converter has a simpler structure and cheaper cost. But it also suffers from same drawbacks as that of isolated converters. Many strategies such as VM cells [15], switched capacitors [16–18], switched inductors [19], and connected inductor (CI) [20, 21] have been incorporated with traditional converters to boost its voltage gain.

High conversion ratios are possible using Switched-Capacitor (SC) converters. However, the converter has a low efficiency and providing a capacitor charging channel is difficult. When the semiconductor switch is activated, a large pulsed current passes through the main switch and numerous diodes, increasing current stress and conduction losses. To eliminate the diode recovery issue and limit the peak current, a resonant inductor is coupled in the switched-capacitor converter [22, 23].

High output voltage gain can be achieved by using converters with a switched-inductor topology. The switched-inductor-based converters make use of two inductors that are charged in parallel and discharged in series. The switched-inductor converter, on the other hand, suffers from extreme voltage stress across the semiconductor switch [24,25].By simply increasing the turns ratio of the converter's connected inductors, a high DC gain can be produced.

A coupled inductor with a high turn's ratio can cause leakage inductances. This results in substantial power dissipation and low efficiency [26].

The leakage inductance energy can be recovered to solve this problem. By using a voltage clamp circuit in CI based converters, good results can be achieved [27–29]. Furthermore, the active clamp circuit may effectively solve the problem of leakage inductance; nevertheless, it is quite expensive because it necessitates high-power switch drive circuits. As a result, the converter with a passive clamp circuit for improved performance was demonstrated [30].

The implementation of clamp circuits in converter offers low voltage stress, energy recovery etc., Nevertheless, the converter has a large input ripple current, which leads to have problems with PV MPPT. To override this, work proposed a SEPIC converter as intermediate converter for PV integration with grid.

A schematic of the three-phase (3 Φ) grid-connected PV system used in this research work is shown in Figure 1.

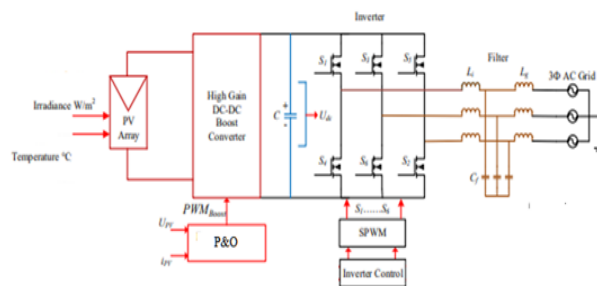

Figure 1. Schematic of 3 Φ grid connected PV system.

II. OPERATION OF THE PROPOSED SYSTEM

The overall system was modeled, designed and implemented in MATLAB®/Simulink environment. Solar PV array generates the direct current power when solar insolation incident on it. The output voltage of solar PV array is boosted to the required level of inverter with the help of the SEPIC converter as shown in the Fig. 1.

For maximum utilization of solar PV array, P&O algorithm is employed which generates the switching pulse for IGBT used in SEPIC converter. P&O algorithm sense the voltage and current produced by solar PV array and track the MPP on I-V characteristics on solar PV array. DC voltage boosted by the SEPIC converter is fed to the inverter. Inverter is operating at the low switching frequency of (1 kHz) to minimize the switching losses. To control the output voltage of inverter, SPWM technique has been implemented.

III.DESIGN OF THE PROPOSED SYSTEM

The solar PV array of peak power $P_{mpp} = 2 \text{ kW}$ under STC (STC=1000 W/m^2 , 25 $^{\circ}\text{C}$) is taken for feeding the power to the grid. soltech 1STH model is implemented in this work. Specifications of this module are listed in the table I

Table 1.Specifications of PV panel

Parameters	Values
Maximum Power	250Watts
Voc	37.3
Vmp	30.7
Isc	8.66
Imp	8.15

A. Design of SEPIC Converter

Circuit diagram of the SEPIC converter is shown in Fig.3. Single Ended Primary Inductor Converter (SEPIC) converter consists of a switch S with duty cycle δ , a diode, two inductors L_1 and L_2 , two capacitors C_1 and C_2 and a load resistor

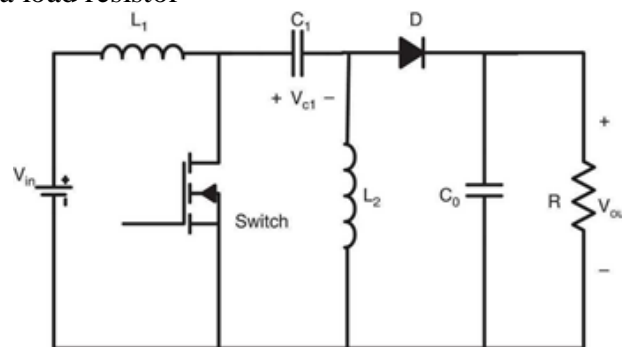
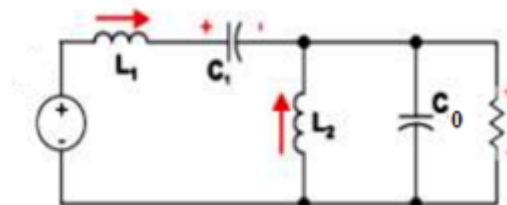
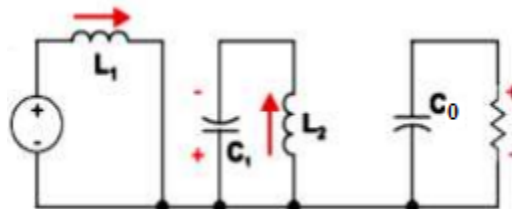

Fig.3. Circuit diagram of the SEPIC converter
Analysis of operating modes of the proposed converter



(a) Switch ON condition



(b) Switch OFF condition

Figure 4. Equivalent circuit diagram (Under switch is ON and OFF condition)

Figure 4 shows the circuit when the power switch is turned on and off (respectively in Figures a and b). When the switch is turned on (Figure 4a), the first inductor is charged from the input voltage source during this time. The second inductor takes energy from the first capacitor, and the output capacitor provides the load current.

When the switch is turned on, the input inductor is charged from the source, and the second inductor is charged from the first capacitor. No energy is supplied to the load capacitor during this time. Inductor

current and capacitor voltage polarities are marked in this Figure. When the power switch is turned off, the energy stored in inductor is transferred to .The energy stored in is transferred to through the diode and supplying the energy to load, as shown in Figure 4b. The second inductor is also connected to the load during this time. The output capacitor sees a pulse of current during the off time, making it inherently noisier than a buck converter. The amount that the SEPIC converters increase or decrease the voltage depends primarily on the duty cycle and the parasitic elements in the circuit.

Thus, the voltage gain of the circuit

$$V_0 = \frac{D}{1-D} V_{in} \quad (1)$$

Selection of Inductor

While designing a Inductor, the inductor ripple current I_L has to be taken into consideration. Thus, it can be calculated using a formula

$$\Delta(I_L) = 30\% \times \left(\frac{I_{in}}{\eta}\right) \quad (2)$$

$$L_1 = L_2 = 1/2 \times \left(\frac{V_{in} \times (D)}{\Delta(I_L) \times (f_s)}\right) \quad (3)$$

Selection of Capacitor

Similarly, the output capacitor can be calculated using the formula

$$C_1 = \frac{I_{out} \times (D_{max})}{\Delta(V_{cp}) \times (f_s)} \quad (4)$$

Thus, the design limits of the components incorporated during simulation is tabulated in table 2.

Table 2. Design parameters of the proposed converters and their values

Parameter	Values
L1,L2	0.0017H
C1	4.5952e-6
C2	500e-6
Vin	200
Vout	600
fs	100e3

B. Design of GWO MPPT Algorithm

To improve the PV system's efficiency and enhance the PV system's performance, the MPPT controller should be used by integration with a boost DC/DC converter. However, the oscillation and lossof-power issues presented in the conventional MPPT techniques used in recent years make the efficiency of the PV system low. As a result, MPPT-based optimization is the best solution for these issues, especially the GWO optimization method..

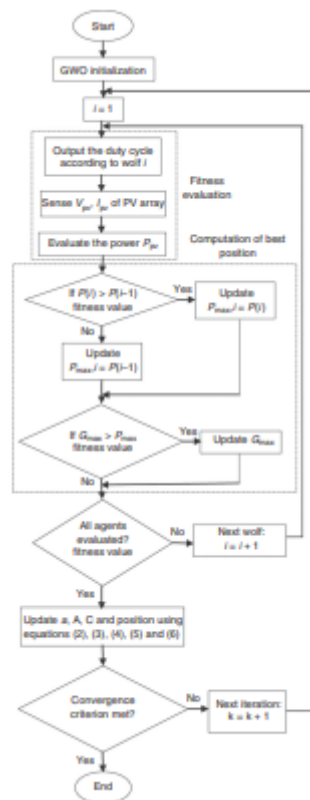

Figure 5. Flowchart of GWO topology

In the proposed grid associated PV system, the 3Φ- inverter interfaces the utility grid and PV system. In this system, SPWM system is incorporated as PWM generator.

V.RESULTS AND DISCUSSION

In this section, the grid associated PV system is examined with the proposed converter.

Analysis under constant irradiance condition

In this mode, the designed PV array delivers 200Vat 1000 W/m² solar radiation. Figure 6 illustrates the generated PV voltage current and power at constant 1000 W/m² solar radiation.

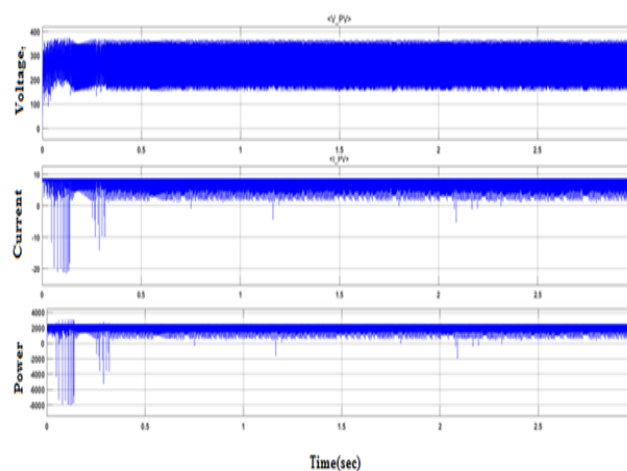

Figure 6. Output obtained from PV

From the above Graph, it is observed that the P &O MPPT topology has the ability to track maximum power from PV under constant irradiance. This, tracked voltage is boosted in to 600 V using a proposed SEPIC converter. The output voltage waveforms of step-up converters were given in Figure 7.

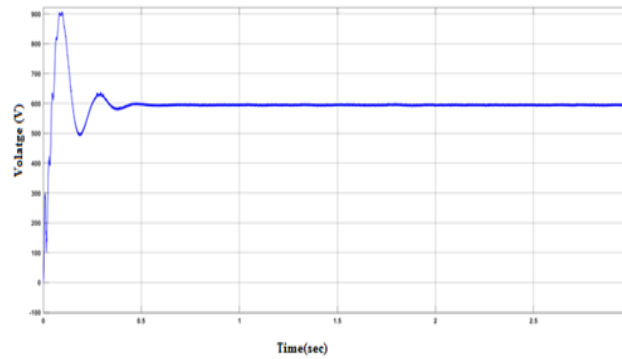

Figure 7. Converter output voltage

SEPIC converter operation in this mode reduces the stress on power devices and other components. The SEPIC converter can automatically adjusted according to the variation in the incident solar insolation to optimize the overall performance of the solar PV array.

Voltage source inverter with SPWM integrates the PV with the Grid. Figure 8 shows the grid voltage and inverter current being injected into the grid.

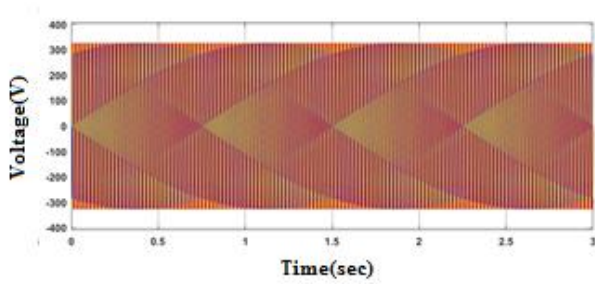

Figure 8 .Output of the inverter

Thus, the overall performance of the proposed system is depicted in figure 9.

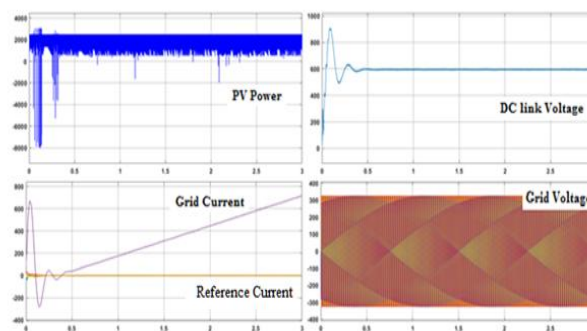

Figure 9. Overall performance of the proposed system

While integrating RES with grid, the power quality measures play a major role. Thus, the harmonic distortion has to be measured to ensure the efficiency of the system. Thus, from the figure 10, the THD of the system was observed.

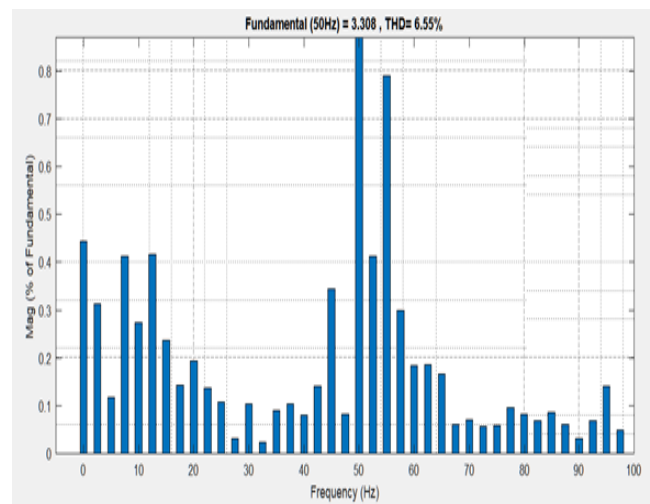

Figure 10. THD analysis of the proposed system

From the THD analysis, it is seen that that the proposed system exhibits 6.55% of THD. Finally, from all these, it is concluded that the suggested system can appropriately responds to all variations in load with improved power quality performance.

VI. CONCLUSION

The aim of this work was to analyze the operation of solar based inverter interacted with SEPIC converter for connection to the grid. It was observed that the THD was very minimal and follows the IEEE standard. The proposed system was feeding power to the grid at unity power factor and the power factor can be controlled according to the requirement of exchange of reactive power. Hence, this system can be implemented in countries where the availability of solar energy is huge. Further, more to maintain a constant voltage level at the inverter side, a controller can be implemented in inverter.

VII. REFERENCES

- [1] S. Shuvo, E. Hossain, and Z. R. Khan, "Fixed point implementation of grid tied inverter in digital signal processing controller," *IEEE Access*, vol. 8, pp. 89215–89227, 2020.
- [2] Q. Chen, X. Luo, L. Zhang, and S. Quan, "Model predictive control for three-phase four-leg grid-tied inverters," *IEEE Access*, vol. 5, pp. 2834–2841, 2017.
- [3] A. Adib, B. Mirafzal, X. Wang, and F. Blaabjerg, "On stability of voltage source inverters in weak grids," *IEEE Access*, vol. 6, pp. 4427–4439, 2018.
- [4] A. Ahmad, N. Ullah, N. Ahmed, A. Ibeas, G. Mehdi, J. Herrera, and A. Ali, "Robust control of grid-tied parallel inverters using nonlinear backstepping approach," *IEEE Access*, vol. 7, pp. 111982–111992, 2019.
- [5] Q. Zhao, S. Chen, S. Wen, B. Qu, and Y. Ye, "A frequency adaptive PIMR-type repetitive control for a grid-tied inverter," *IEEE Access*, vol. 6, pp. 65418–65428, 2018.
- [6] I. S. Mohamed, S. Rovetta, T. D. Do, T. Dragicevic, and A. A. Z. Diab, "A neural-network-based model predictive control of three-phase inverter with an output LC filter," *IEEE Access*, vol. 7, pp. 124737–124749, 2019.
- [7] S. Rahman, M. Meraj, A. Iqbal, and L. Ben-Brahim, "Optimized FPGA implementation of PWAM-based control of three—Phase nine—Level quasi impedance source inverter," *IEEE Access*, vol. 7, pp. 137279–137290, 2019.
- [8] A. Shawky, M. Ahmed, M. Orabi, and A. E. Aroudi, "Classification of three-phase grid-tied microinverters in photovoltaic applications," *Energies*, vol. 13, no. 11, p. 2929, Jun. 2020.
- [9] A. Shawky, A. Shier, M. Orabi, J. A. Qahouq, and M. Youssef, "A high efficiency single-stage current source inverter for photovoltaic applications," in *Proc. 35th Int. Telecommun. Energy Conf., Smart Power Efficiency*, Hamburg, Germany, Oct. 2013, pp. 1–6.
- [10] R. Hasan, S. Mekhilef, M. S. Seyedmahmoudian, and B. Horan, "Gridconnected isolated PV microinverters: A review," *Renew. Sustain. Energy Rev.*, vol. 67, pp. 1065–1080, Jan. 2017.

- [11] F. E. U. Reis, R. P. Torrico-Bascope, F. L. Tofoli, and L. D. S. Bezerra, "Bidirectional three-level stack clamped converter for electric vehicle charging stations," *IEEE Access*, vol. 8, pp. 37565–37577, 2020.
- [12] C. Chen, H. Zhou, Q. Deng, W. Hu, Y. Yu, X. Lu, and J. Lai, "Modeling and decoupled control of inductive power transfer to implement constant current/voltage charging and ZVS operating for electric vehicles," *IEEE Access*, vol. 6, pp. 59917–59928, 2018.
- [13] Alghaythi, M.L., Oconnell, R.M., Islam, N.E. and Guerrero, J.M., 2020. A Non-Isolated High Step-Up Interleaved DC-DC Converter with Diode-Capacitor Multiplier Cells and Dual Coupled Inductors. *arXiv preprint arXiv:2009.04602*.
- [14] Wu H, Xia T, Zhan X, Xu P, Xing Y (2015) Resonant converter with resonant-voltage-multiplier rectifier and constant frequency phase-shift control for isolated buck–boost power conversion. *IEEE Trans Ind Electron* 62(11):6974–6985
- [15] Andrade AMSS, Mattos E, Schuch L, Hey HL, Da Silva Martins ML (2018) Synthesis and comparative analysis of very high step-up DC–DC converters adopting coupled-inductor and voltage multiplier cells. *IEEE Trans Power Electron* 33(7):5880–5897
- [16] Radmand F, Jalili A (2017) A novel switched-capacitor based step-up DC/DC converter for renewable energy system applications. *J Power Electron* 17(6):1402–1412
- [17] Ye Y, Cheng KWE, Chen S (2017) A high step-up PWM DC–DC converter with coupled-inductor and resonant switched-capacitor. *IEEE Trans Power Electron* 32(10):7739–7749
- [18] He L, Zheng Z (2017) High step-up DC–DC converter with switched-capacitor and its zero-voltage switching realization. *IET Power Electron* 10(6):630–636
- [19] Yassera A, Mohammad M (2018) Three topologies of a non-isolated high gain switched-inductor switched-capacitor step-up Cuk converter for renewable energy applications. *Electronics* 7:1–24
- [20] Hamkari S, Moradzadeh M, Zamiri E, Nasiri M, Hosseini SH (2017) A novel switching capacitor high step-up dc/dc converter using a coupled inductor with its generalized structure. *J Power Electron* 17(3):579–589
- [21] Kumar A, Sensarma P (2019) Ripple-free input current high voltage gain dc–dc converters with coupled inductors. *IEEE Trans Power Electron* 34(4):3418–3428
- [22] A. Mirzaee and J. S. Moghani, "Coupled Inductor-Based High Voltage Gain DC–DC Converter For Renewable Energy Applications," in *IEEE Transactions on Power Electronics*, vol. 35, no. 7, pp. 7045–7057, July 2020.
- [23] Prudente M, Pfitscher LL, Emmendoerfer G, Romanelli EF, Gules R (2008) Voltage multiplier cells applied to non-isolated DC–DC converters. *IEEE Trans Power Electron* 23(2):871–887
- [24] Maroti PK, Sanjeevikumar P, Bhaskar MS, Blaabjerg F, Ramachandaramurthy VK, Siano P, Fedak V (2017) Multistage switched inductor boost converter for renewable energy applications. In: *Proceedings of IEEE conference on energy conversion*, Kuala Lumpur, pp 311–316
- [25] Maheri HM, Babaei E, Sabahi M, Hossein S (2017) High step-up DC–DC converter with minimum output voltage ripple. *IEEE Trans Ind Electron* 64(5):3568–3575
- [26] Zhao Y, Li W, Deng Y, He X (2011) High step-up boost converter with passive lossless clamp circuit for non-isolated high step-up applications. *IET Power Electron* 4(8):851–859
- [27] Premkumar M, Sumithira TR (2019) Design and implementation of new topology for non-isolated DC–DC microconverter with effective clamping circuit. *J Circuits Sys Comput* 28(5):1950082-1-22
- [28] Sahin Y, Ting NS (2017) Soft-switching passive snubber cell for family of PWM DC–DC converters. *ElectrEng* 100(3):1785–1796
- [29] Premkumar M, Kumar C, Sowmya R (2019) Analysis and implementation of high-performance DC–DC step-up converter for multilevel boost structure. *Front Energy Res* 7:149
- [30] Tseng KC, Huang CC (2014) High step-up, high efficiency interleaved converter with voltage multiplier module for renewable energy system. *IEEE Trans Ind Electron* 61(3):1311–1319